

Max REGER

Monologe op. 63
Heft 1

herausgegeben von / edited by
Alexander Becker, Christopher Graftschmidt,
Stefan König und Stefanie Steiner-Grage

Einzelausgabe aus der / Separate edition from
Reger-Werkausgabe
Abteilung I: Orgelwerke
Band 5: Orgelstücke I

Editionsleitung / Editorial Directors:
Susanne Popp und Thomas Seedorf

Für Vorwort und Kritischen Bericht verweisen wir auf den
Band der Werkausgabe sowie die zugehörige DVD.
Die DVD ist auch separat erhältlich.

For Foreword and Critical Report please refer to the volume
from the Werkausgabe and the respective DVD.
The DVD is also available separately.

Monologe Zwölf Stücke

für Orgel
Opus 63 (1902)

Heft 1 (Nr. 1–4): *Herrn Dr. Hermann Dettmer zugeeignet*

Max Reger
1873–1916

Nr. 1 Präludium

Allegro con moto (♩ = 96)

Manuale

I. Man *f* *e* *sempre* *cre - - - - -* *scen - - - - -* *do* *più f* *cre -*

C II, III

Pedal *f*

3

- - - - - *scen - - - - -* *do ff* *sempre* *a poco* *cre -*

- - - - - *scen - - - - -* *ff*

5

- - - - - *scen*

sempre *cre - - - - -* *scen*

poco ritardando

7

do *fff* II. Man *mf* un poco crescendo

do *fff*

This system contains measures 7 and 8. The top staff features a vocal line with lyrics 'do' and 'do' and piano accompaniment. The middle staff is labeled 'II. Man' and 'un poco crescendo'. The bottom staff continues the piano accompaniment.

9

a tempo I. Man *f* II. Man I. Man

f

This system contains measures 9 and 10. The top staff has lyrics 'I. Man' and 'II. Man'. The middle staff is labeled 'I. Man' and 'un poco crescendo'. The bottom staff continues the piano accompaniment.

11

sempre poco cre - - -

poco a poco cre - - -

This system contains measures 11 and 12. The top staff has lyrics 'poco cre - - -'. The middle staff has lyrics 'poco a poco cre - - -'. The bottom staff continues the piano accompaniment.

(12)

do *ff*

scen - - - do *ff*

This system contains measures 12 and 13. The top staff has lyrics 'do' and 'scen'. The middle staff has lyrics 'do' and 'do'. The bottom staff continues the piano accompaniment.

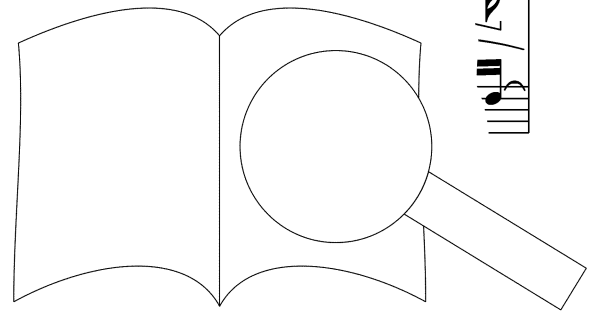

14 *(sempre vivace)*

sempre cre - - - - - scen - - - - - do

più ff e sempre ben legato

ben marcato

più ff

15

sempre r

17 *(sempre vivace)*

scen - - - - -

18

tr

+ C II

f e

tr

2

(sempre vivace)

20

[*tr*]
sempre *poco* *a* *poco* *cre*

sempre *poco* *a* *poco* *cre*

sempre *strin - - gen - - do* *poco rit. (kurz)*

(21)

scen - - do *Org Pl*

scen - - do

24

ppp

27

poco ritardando *a tempo*

mp

* Ta - scher Bericht. / See the Critical Report.

Carus 52.88.

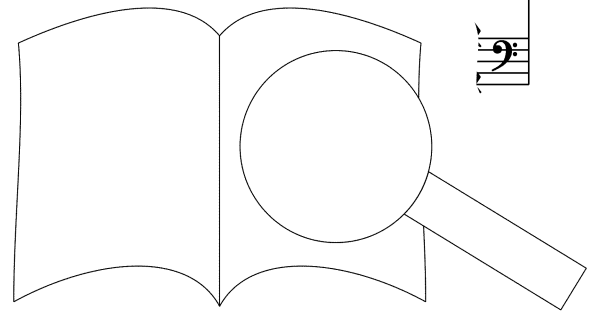

PROBEKOPPIE
 Ausgabqualität gegenüber Original evtl. gemindert • Evaluation Copy - Quality may be reduced • Carus-Verlag

31 (III. Man 8', 4') (III. Man)

II. Man 8'

pp (nur äußerst zart hervortretend) *pp* *ppp*

(II. Man) *ppp*

35 *poco ritardando* *a tempo* (III. Man) *sempre ben legato*

molto *ppp* *meno pp*

(II. Man, äußerst zart he)

38 *poco ritenuto*

quasi f *ppp* III. Man

pp *ppp*

41 **Tempo** (quasi vivace assai)

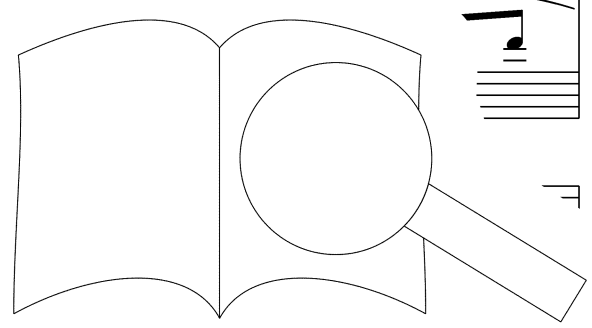

PROBENFÜR
Ausgabequalität gegenüber Original evtl. gemindert • Evaluation Copy - Quality may be reduced • Carus-Verlag

43

sempre poco a poco cre

sempre poco a poco cre

44

scen

scen

45

(molto agitato)

sempre cre do

sempre cre do

46

do

47

3

sempre *fff*

e

poco

(48)

[*a poco*]

cre

fff *e* *sempre* *cre*

(sempre vivace)

50

scen

scen

poco ritardando

52

do

Org Pl

PROBENPARTIE

Ausgabequalität gegenüber Original evtl. gemindert • Evaluation Copy - Quality may be reduced • Carus-Verlag

Nr. 2 Fuge

Con moto (♩. = 72)

mf
II. Man 8', 4' *sempre un poco cre - - - - -* II. Man *scen - - - - -*

(3) *f* *do* *f*

(6) *più f* .. Man)

(8)

PROBEN
Ausgabequalität gegenüber Original evtl. gemindert • Evaluation Copy - Quality may be reduced • Carus-Verlag

10 *poco rit.* *a tempo*

sempre f *sempre poco a poco cre*

marcato *sempre poco a poco cre*

12

scen *do*

(13)

più f e sempre cre

più f e sempre cre

15

(II. Man)

ff *marcato*

do *do*

PROBEPARTITUR

Ausgabequalität gegenüber Original evtl. gemindert • Evaluation Copy - Quality may be reduced • Carus-Verlag

17

sempre ff I. Man

marcato

This system contains measures 17 and 18. It features three staves: a grand staff (treble and bass clefs) and a separate bass clef staff below. The music is in a key with one sharp (F#) and a 2/4 time signature. Measure 17 has a treble clef staff with a melodic line and a bass clef staff with accompaniment. Measure 18 continues the melodic line in the treble clef staff and the accompaniment in the bass clef staff. The dynamic marking *sempre ff* is placed above the treble clef staff, and *I. Man* is written to the right. The marking *marcato* is placed above the bottom bass clef staff.

19

This system contains measures 19 and 20. It features three staves: a grand staff (treble and bass clefs) and a separate bass clef staff below. The music continues with a melodic line in the treble clef staff and accompaniment in the bass clef staff. The dynamic marking *sempre ff* from the previous system is still present.

21

più ff

più ff

This system contains measures 21 and 22. It features three staves: a grand staff (treble and bass clefs) and a separate bass clef staff below. The dynamic marking *più ff* appears above the treble clef staff in measure 21 and below the bottom bass clef staff in measure 21.

(22)

poco ritardando *a tempo* II. Man

This system contains measures 22 and 23. It features three staves: a grand staff (treble and bass clefs) and a separate bass clef staff below. The dynamic marking *più ff* is still present. The marking *poco ritardando* is placed above the treble clef staff, and *a tempo* is placed above the bottom bass clef staff. *II. Man* is written to the right. A large watermark 'PROBEPARTITUR' is overlaid on the page, and a magnifying glass icon is visible in the bottom right corner.

24

(II. Man)

f

I. Man

cre - - - - - scen - - - - - do

(25)

27

sempre

I. Man

cre - - - - - scen -

ff

(28)

sempre

cre - -

sempre

cre - -

PROBEPARTITUR

Ausgabequalität gegenüber Original evtl. gemindert • Evaluation Copy - Quality may be reduced • Carus-Verlag

(quasi poco ritardando)

30

scen - - - - - do *fff*

scen - - - - - do *fff*

Musical score for measures 30-31. The system consists of three staves: a vocal line in treble clef and two piano accompaniment staves in bass clef. The vocal line has lyrics 'scen' and 'do' with a dynamic marking of *fff*. The piano accompaniment features a rhythmic pattern of eighth and sixteenth notes.

(31)

a tempo

II. Man (8', 4')

p *poco meno p*

Musical score for measures 31-32. The system consists of three staves. The vocal line has a dynamic marking of *p*. The piano accompaniment includes a section for the second hand, marked 'II. Man (8', 4')' and *p*, with a dynamic marking of *poco meno p*.

33

un poco cre - - - - - do

Musical score for measures 32-33. The system consists of three staves. The vocal line has lyrics 'un poco cre' and 'do'. The piano accompaniment continues with the rhythmic pattern from the previous system.

(34)

mf

cre - - - - -

marcato e sempre cre - - - - -

Musical score for measures 33-34. The system consists of three staves. The vocal line has a dynamic marking of *mf* and lyrics 'cre'. The piano accompaniment includes a section marked *marcato e sempre cre*. There is a large graphic of an open book on the right side of the page.

36

do *f* e sempre poco a poco cre

+ C II

do *f* e sempre poco a poco cre

(37)

scen

scen

39

do più *f* e sempre cre

do

(40)

scen

PROBENPARTI FÜR
Ausgabequalität gegenüber Original evtl. gemindert • Evaluation Copy - Quality may be reduced • Carus-Verlag

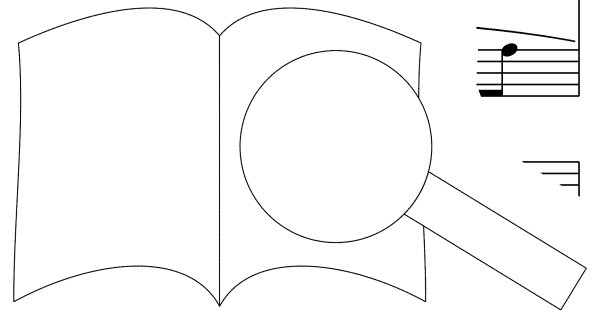

42

(43) (II. Man)

sempre ff e sempre cre

I. Man

sempre ff e sempre cre

45

scen

I. Man

scen do più ff

(46)

48 (I. Man)
+ C II
fff
assai marcato
fff

(49)

51
assai marcato

(52)
sempre

PROBENPARTITUR
Ausgabequalität gegenüber Original evtl. gemindert • Evaluation Copy - Quality may be reduced • Carus-Verlag

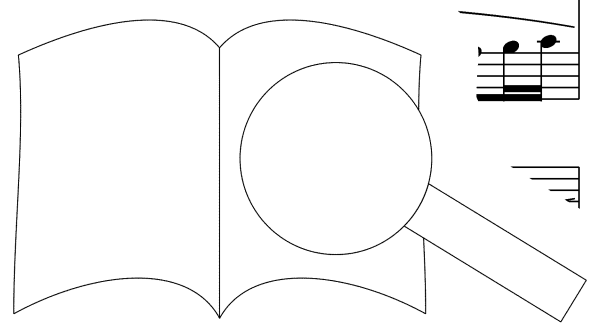

54

sempre *fff* e poco a poco cre - -

sempre *fff* e poco a poco cre - -

(sempre vivace)

poco a

This system contains the first two systems of music. The first system has three staves (treble, bass, and a lower bass staff) with a melodic line in the treble and accompaniment in the bass. The second system continues the same three-staff structure. The tempo marking '(sempre vivace)' is placed above the second system. The dynamic marking 'sempre fff e poco a poco cre' is written across both systems.

(55)

scen - - - - -

scen - - - - -

poco sempre strin - - - - - do

This system contains the next two systems of music. The first system has three staves with a melodic line in the treble and accompaniment in the bass. The second system continues the same three-staff structure. The tempo marking '(sempre vivace)' is placed above the first system. The dynamic marking 'poco sempre strin' is written across the second system, and 'do' is written at the end of the system.

57

scen - - - - -

scen - - - - -

scen - - - - -

This system contains the next two systems of music. The first system has three staves with a melodic line in the treble and accompaniment in the bass. The second system continues the same three-staff structure. The third system continues the same three-staff structure. The tempo marking '(sempre vivace)' is placed above the first system. The dynamic marking 'poco sempre strin' is written across the second system, and 'do' is written at the end of the system.

(58)

ritardando

ritardando Adagio

Org PI

do

This system contains the final two systems of music. The first system has three staves with a melodic line in the treble and accompaniment in the bass. The second system continues the same three-staff structure. The tempo marking 'ritardando' is placed above the first system, and 'ritardando Adagio' is placed above the second system. The dynamic marking 'Org PI' is written below the second system, and 'do' is written at the end of the system.

Nr. 3 Canzone

Andante con moto
con espressione

II. Man 8'
pp

III. Man 8', 4'

3

This system contains the first four measures of the piece. It features a treble clef with a key signature of two flats and a 3/4 time signature. The piano part is written in a grand staff with treble and bass clefs. The right hand has a piano (*pp*) dynamic. The left hand has a mezzo-forte (*mf*) dynamic. A triplet of eighth notes is marked with a '3' above it.

5

molto *pp* *meno r*

This system contains measures 5 through 8. The dynamics are marked as *molto*, *pp*, and *meno r*. The piano part continues with a complex accompaniment.

9

pp

This system contains measures 9 through 12. The piano part features a *pp* dynamic. The right hand has a melodic line with some grace notes.

13

poco ri - tar - dan - do

This system contains measures 13 through 16. The lyrics 'poco ri - tar - dan - do' are written below the notes. The piano part continues with a steady accompaniment.

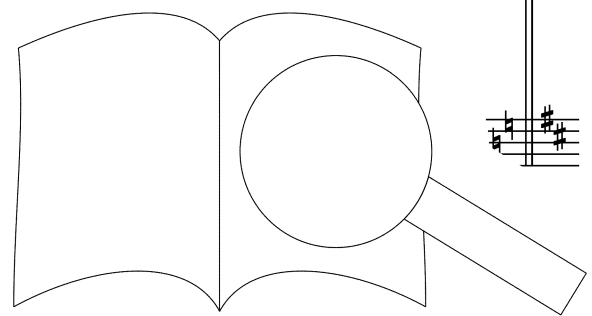

Più mosso

16

II. Man
mf

19

f 8', 4'

f

ser

tar - dan - do

Tempo primo (Andante con r

III. Man *pp* (8', 4')

pp

(Man) 8'

pp

26

molto

poco strin - - gen - -

29

meno pp e cre - - - scen - - - do

- - - do ritardando a tempo

II. Man (8')
(..... äußerst)

32

quasi f *pp* III. Man *ppp*

zart hervortretend

36

40

ff *mp* *agitato* *mp*

PROBENPARTIEN
Ausgabequalität gegenüber Original evtl. gemindert • Evaluation Copy - Quality may be reduced • Carus-Verlag

44

f *p* *trill* *3*

48

pp *mf* *pp* *mf*

51

un poco ri - tar - dan - do Un poco

p *pp* *ppp*

55

poco ri - tar - dan - do

molto *ppp*

PROBENPAPIER

Ausgabequalität gegenüber Original evtl. gemindert • Evaluation Copy - Quality may be reduced • Carus-Verlag

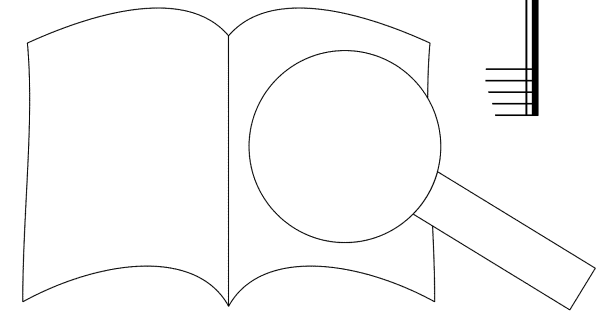

Nr. 4 Capriccio

Allegro vivace assai

III. Man *f* 8', 4'

II. Man *f* 8', 4'

4

I. Man *più f e cre - - - - - scen*

f e cre - - - - - scen do

7

III. Man *do ff pp e cr - - - - - scen - - - - - do*

II

10

tr - - - - -

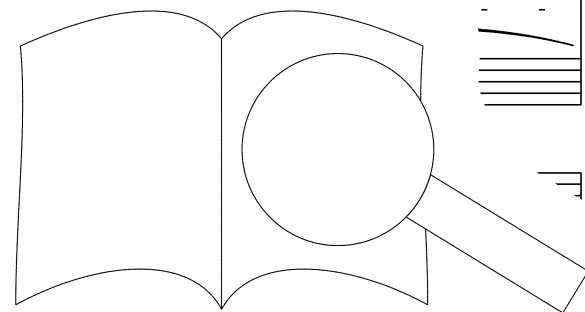

13

scen - - - do **ff**

scen - - - do **ff**

16

III. Man *sempre f*

II. Man *più f*

I. Man *più f*

f e cre - - -

19

III. Man **ff**

II. Man

do **ff**

mpre ff e cre - - -

22

scen

do **fff**

do **fff**



25

II. Man *p* e sempre poco a poco cre - - - - -

p e sempre poco a poco cre - - - - -

28

scen - - - - - do *ff*

scen - - - - -

30

II. Man *f* Man *pp*

ff *p*

33

II. Mar

re cre

PROBEPARTITUR

Ausgabequalität gegenüber Original evtl. gemindert • Evaluation Copy - Quality may be reduced • Carus-Verlag

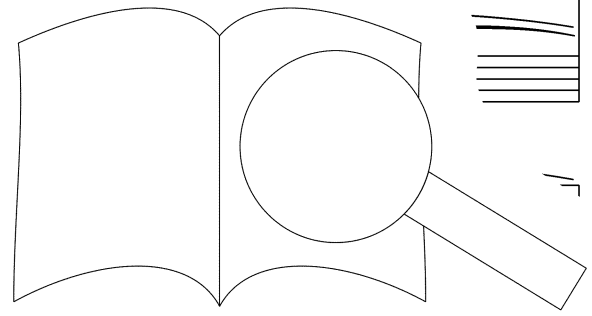

35

do

I. Man *ff e sempre cre*

do *ff e sempre cre*

38

scen

do

fff

scen

40

poco a poco r tar do

tr

sempre f.

Quasi meno mosso

43

III. Man 8'

p

poco *pp*

pp

51

ppp *poco* *quasi f*

ppp *quasi f*

poco ri - tar - dan - do

Tempo primo
(Allegro vivace assa^o)

ppp II. Man *f*

ppp *poco a*

62

poco cre - - - - -

poco cre - - - - - scen - - - - -

III. Man

65

cre - - - - -

I. Man

cre - - - - -
I. Man

PROBEPARTITUR

Ausgabequalität gegenüber Original evtl. gemindert • Evaluation Copy - Quality may be reduced • Carus-Verlag

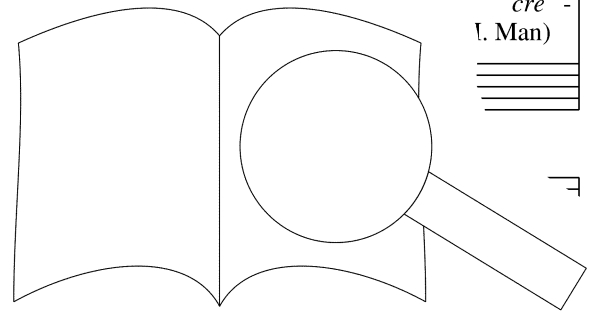

68 *(sempre)*

scen - - - do

più ff

I. Man

scen - - - do *più ff* *fff* *mf* *e*

71 *vivace assai*

mf *e* *sempre* *cre*

III. Man II. Man III. Man I. Man

sempre poco a poco cre

74

do *f* *e* *sempre* *cre*

II. Man I. Man

scen - - -

do *f* *e* scen - - -

77

I. Man

ff



80 *(sempre vivace assai)*

I. Man *più ff* *e* *sempre* *poco* *a* *poco*

+ C I, II, III

più ff *e* *sempre* *poco* *a* *poco*

82

cre

cre

85

+ C III *scen*

scer

88

sempre

do *Orso DI*

do

Druckbogen im Erstdruck unvollständig. Beginn möglicherweise in Takt 82, *gins* in m. 82, beat 2.

