

Max REGER

Drei Stücke op. 7

herausgegeben von / edited by
Alexander Becker, Christopher Graf Schmidt,
Stefan König und Stefanie Steiner-Grage

Einzelausgabe aus der / Separate edition from
Reger-Werkausgabe
Abteilung I: Orgelwerke
Band 5: Orgelstücke I

Editionsleitung / Editorial Directors:
Susanne Popp und Thomas Seedorf

Für Vorwort und Kritischen Bericht verweisen wir auf den
Band der Werkausgabe sowie die zugehörige DVD.
Die DVD ist auch separat erhältlich.

For Foreword and Critical Report please refer to the volume
from the Werkausgabe and the respective DVD.
The DVD is also available separately.

Samuel de Lange gewidmet

Drei Stücke

für Orgel

Opus 7 (1892)

Nr. 1 Präludium und Fuge

Max Reger
1873–1916

Moderato

Manuale

II. Man *p* 8', 4'

crescendo

Pedal

4

16,

7

I. M

I. Man

tr

10

tr

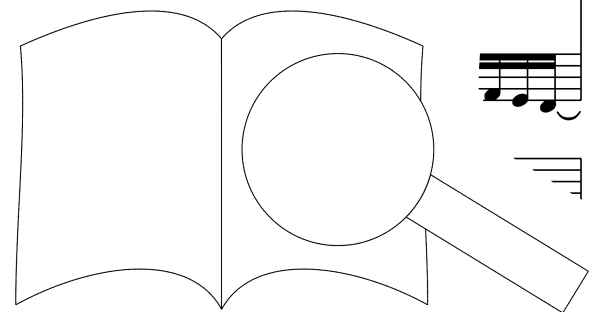

13

16

II. Man *f*

(I. Man) *f*

18

20

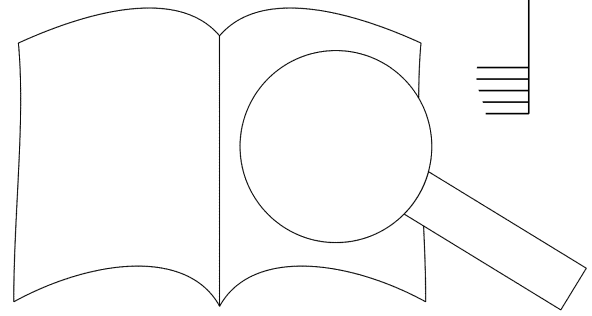

22

Musical score for measures 22-23. The system consists of three staves: a grand staff (treble and bass clefs) and a separate bass clef staff below. The music features a complex melodic line in the right hand with many slurs and ties, and a more rhythmic accompaniment in the left hand.

24

Musical score for measures 24-25. The system consists of three staves: a grand staff (treble and bass clefs) and a separate bass clef staff below. The music continues with intricate melodic patterns and accompaniment.

26

I. Man

Musical score for measures 26-28. The system consists of three staves: a grand staff (treble and bass clefs) and a separate bass clef staff below. Measure 26 includes the instruction "I. Man". The music features a mix of melodic and rhythmic elements.

29

Musical score for measures 29-31. The system consists of three staves: a grand staff (treble and bass clefs) and a separate bass clef staff below. Measure 29 includes the instruction "I. Man". The music features a mix of melodic and rhythmic elements.

+ 32'

PROBEPARTITUR

Ausgabequalität gegenüber Original evtl. gemindert • Evaluation Copy - Quality may be reduced • Carus-Verlag

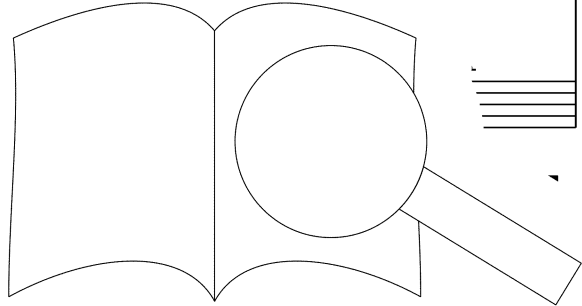

32

Full Organ

Full Pedal

35

allargando

38

trium

(Full Organ)

41

allargando

PROBEPARTITUR

Ausgabequalität gegenüber Original evtl. gemindert • Evaluation Copy - Quality may be reduced • Carus-Verlag

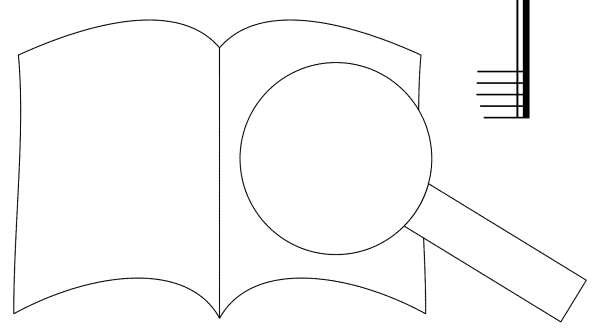

Allegro brillante

[I. Man]

8', 4'

Musical notation for measures 1-3. The score is written for piano with a grand staff (treble and bass clefs). The right hand features a complex rhythmic pattern of eighth and sixteenth notes, while the left hand has a simpler accompaniment. A fermata is placed over the first measure.

Musical notation for measures 4-5. Measure 4 is marked with an asterisk (*). The right hand continues with intricate rhythmic patterns, and the left hand provides harmonic support. A fermata is present at the end of measure 5.

Musical notation for measures 6-8. The right hand features a series of sixteenth-note runs. The left hand has a steady accompaniment. A fermata is placed over measure 8.

Musical notation for measures 9-12. Measure 9 is marked with a '1' and 'an'. The right hand has a melodic line with some grace notes. The left hand continues with its accompaniment. A fermata is placed over measure 12.

an der Takte 4, 13, 27 und 73 siehe Kritischer Bericht, II. Orthografische I report, II. Orthografische Besonderheiten.

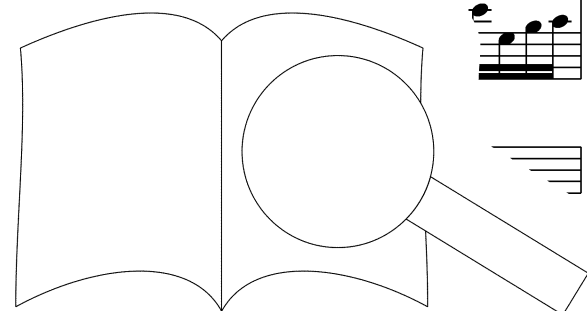

12

16, 8'

14

17

20

PROBEPARTITUR

Ausgabequalität gegenüber Original evtl. gemindert • Evaluation Copy - Quality may be reduced • Carus-Verlag

23

26

(27)

30

PROBEPARTITUR

Ausgabequalität gegenüber Original evtl. gemindert • Evaluation Copy - Quality may be reduced • Carus-Verlag

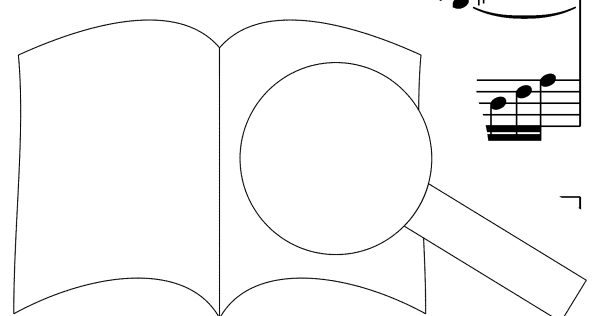

33

36

ritardando

39

a tempo

II. Man *p* 8', 4'
brillante

I. Man *f*

41

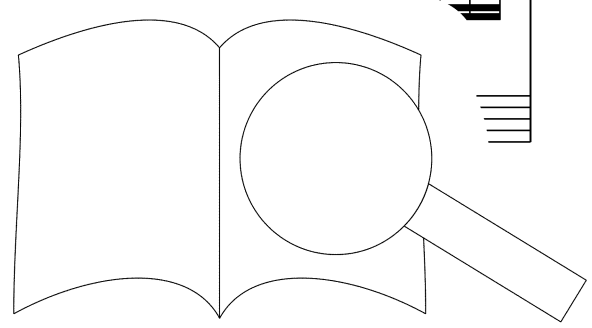

43

I. Man

p

(II. Man)

45

+ 2'

47

49

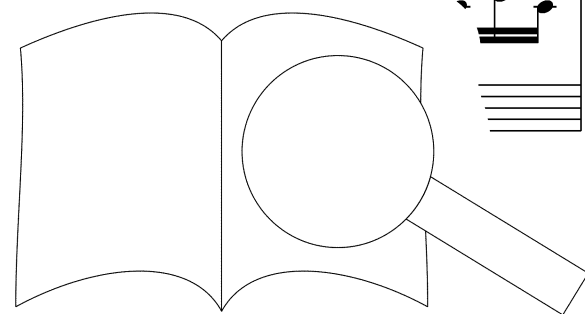

PROBEPARTITUR
Ausgabequalität gegenüber Original evtl. gemindert • Evaluation Copy - Quality may be reduced • Carus-Verlag

51

Full Organ

ff

53

II. Man

6

p

(I. Man)

p

55

II. Man

p

(I. Man)

p

57

PROBEPARTITUR

Ausgabequalität gegenüber Original evtl. gemindert • Evaluation Copy - Quality may be reduced • Carus-Verlag

59

6

I. Man *f*

6

Musical score for measures 59-60. Measure 59 features a complex rhythmic pattern in the right hand with sixteenth notes and slurs. Measure 60 begins with a sixteenth-note triplet in the right hand, indicated by a '6' above the staff, and continues with a similar pattern in the left hand, also marked with a '6' below the staff. The tempo marking 'I. Man' and dynamic 'f' are present.

61

Musical score for measures 61-62. Measure 61 shows a continuation of the sixteenth-note patterns in both hands. Measure 62 features a more melodic line in the right hand with slurs and a steady bass line in the left hand.

63

Musical score for measures 63-64. Measure 63 continues the sixteenth-note texture. Measure 64 shows a change in the right hand's pattern, moving towards a more rhythmic, dotted-note structure.

65

Musical score for measures 65-66. Measure 65 features a melodic line in the right hand with slurs. Measure 66 continues the melodic development in the right hand and the bass line in the left hand.

PROBEPARTITUR

Ausgabequalität gegenüber Original evtl. gemindert • Evaluation Copy - Quality may be reduced • Carus-Verlag

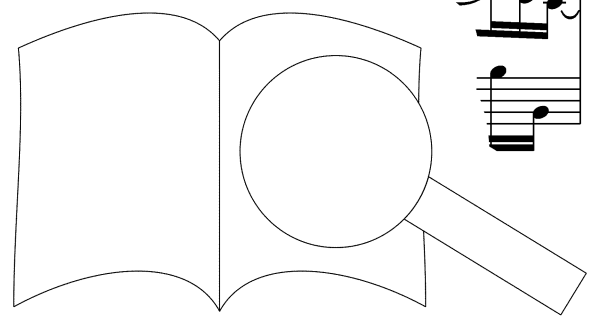

67

Musical score for measures 67-68. The system consists of three staves: a treble clef staff at the top, and two bass clef staves below it. The music features a complex rhythmic pattern with many sixteenth and thirty-second notes. Measure 67 starts with a treble clef staff containing a series of sixteenth notes, while the bass clef staves have fewer notes. Measure 68 continues the pattern with more intricate rhythmic figures.

69

Musical score for measures 69-70. The system consists of three staves: a treble clef staff at the top, and two bass clef staves below it. Measure 69 shows a continuation of the rhythmic complexity from the previous system. Measure 70 features a more melodic line in the treble clef staff, with the bass clef staves providing harmonic support.

71

Musical score for measures 71-72. The system consists of three staves: a treble clef staff at the top, and two bass clef staves below it. Measure 71 has a treble clef staff with rhythmic patterns, while the bass clef staves are mostly empty. Measure 72 shows a continuation of the treble clef staff's activity, with the bass clef staves remaining empty.

73

Musical score for measures 73-74. The system consists of three staves: a treble clef staff at the top, and two bass clef staves below it. Measure 73 has a treble clef staff with rhythmic patterns, while the bass clef staves are mostly empty. Measure 74 shows a continuation of the treble clef staff's activity, with the bass clef staves remaining empty.

PROBEPARTITUR

Ausgabequalität gegenüber Original evtl. gemindert • Evaluation Copy - Quality may be reduced • Carus-Verlag

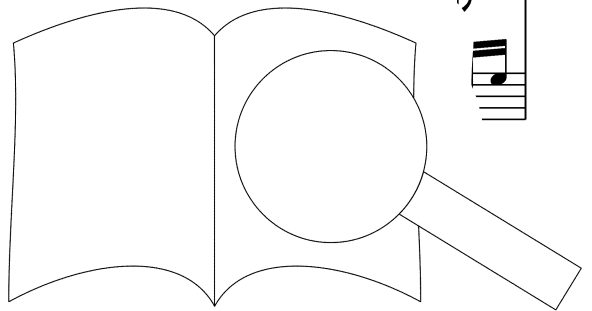

75

Musical score for measures 75-76. The top staff is in treble clef with a key signature of one sharp (F#). The bottom staff is in bass clef. The music consists of a melody in the right hand and a bass line in the left hand.

77

Musical score for measures 77-78. The top staff is in treble clef with a key signature of one sharp (F#). The bottom staff is in bass clef. The music consists of a melody in the right hand and a bass line in the left hand.

80

Musical score for measures 80-81. The top staff is in treble clef with a key signature of one sharp (F#). The bottom staff is in bass clef. The music consists of a melody in the right hand and a bass line in the left hand.

83

Musical score for measures 83-84. The top staff is in treble clef with a key signature of one sharp (F#). The bottom staff is in bass clef. The music consists of a melody in the right hand and a bass line in the left hand.

PROBEEPARTHEUR

Ausgabequalität gegenüber Original evtl. gemindert • Evaluation Copy - Quality may be reduced • Carus-Verlag

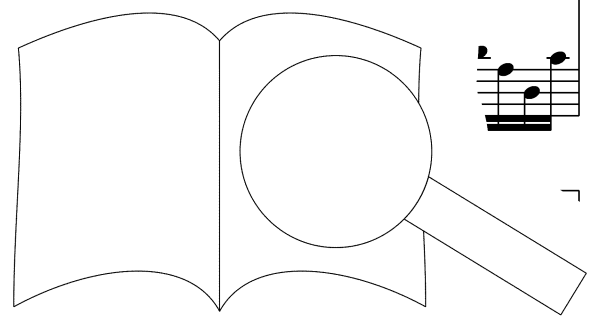

86

ff

Musical score for measures 86-88. The system consists of three staves. The top staff is in treble clef, the middle in bass clef, and the bottom in bass clef. Measure 86 features a melodic line in the treble and a rhythmic accompaniment in the bass. Measure 87 has a dynamic marking of *ff* and continues the accompaniment. Measure 88 shows a continuation of the accompaniment with some melodic movement in the treble.

89

Musical score for measures 89-91. The system consists of three staves. Measure 89 has a melodic line in the treble and a rhythmic accompaniment in the bass. Measure 90 continues the accompaniment. Measure 91 shows a continuation of the accompaniment with some melodic movement in the treble.

92

Musical score for measures 92-94. The system consists of three staves. Measure 92 has a melodic line in the treble and a rhythmic accompaniment in the bass. Measure 93 continues the accompaniment. Measure 94 shows a continuation of the accompaniment with some melodic movement in the treble.

95

Musical score for measures 95-97. The system consists of three staves. Measure 95 has a melodic line in the treble and a rhythmic accompaniment in the bass. Measure 96 continues the accompaniment. Measure 97 shows a continuation of the accompaniment with some melodic movement in the treble.

PROBEEPARTITUR

Ausgabequalität gegenüber Original evtl. gemindert • Evaluation Copy - Quality may be reduced • Carus-Verlag

Nr. 2 Fantasie über



Adagio

8', 4'

I. Man *f*

5

9

8', 16'

6', 4'

12

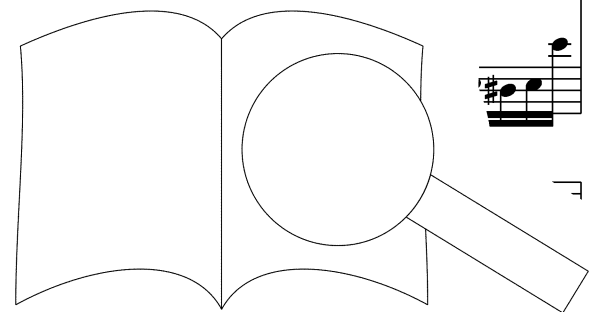

PROBEPARTITUR
Ausgabequalität gegenüber Original evtl. gemindert • Evaluation Copy - Quality may be reduced • Carus-Verlag

14

16

18

20

I. Man

22

(I. Man)

f 8', 4'

II. Man

24

26

I. Man

30

PROBEPARTITUR

Ausgabequalität gegenüber Original evtl. gemindert • Evaluation Copy - Quality may be reduced • Carus-Verlag

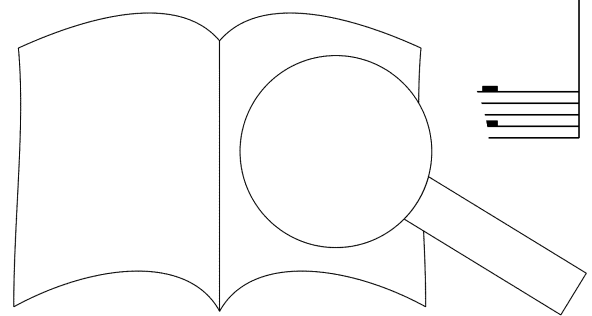

34 (II. Man)

I. Man

mf

37

I. Man *f* 8', 4'

40

f

43

a1

ff

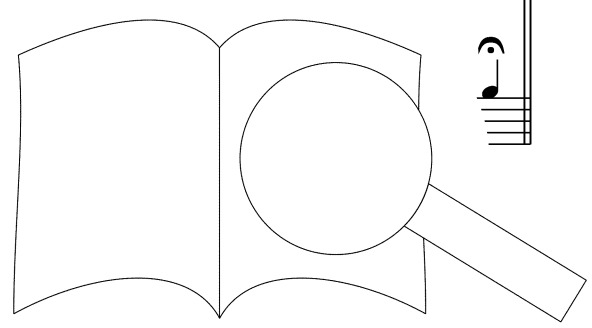

a tempo

47 II. Man

Musical score for measures 47-48. The system includes a grand staff with treble and bass clefs, and a separate bass clef line below. The treble clef part features a complex rhythmic pattern with many sixteenth notes. The bass clef part has a simpler accompaniment with some slurs. A dynamic marking *p* is present in the first measure.

49

Musical score for measures 49-50. The treble clef part continues with the complex rhythmic pattern. The bass clef part has a more active accompaniment with some slurs. A dynamic marking *p* is present in the first measure.

51

Musical score for measures 51-52. The treble clef part continues with the complex rhythmic pattern. The bass clef part has a more active accompaniment with some slurs. A dynamic marking *p* is present in the first measure.

53

Musical score for measures 53-54. The treble clef part continues with the complex rhythmic pattern. The bass clef part has a more active accompaniment with some slurs. A dynamic marking *p* is present in the first measure.

PROBEPARTITUR
Ausgabequalität gegenüber Original evtl. gemindert • Evaluation Copy - Quality may be reduced • Carus-Verlag

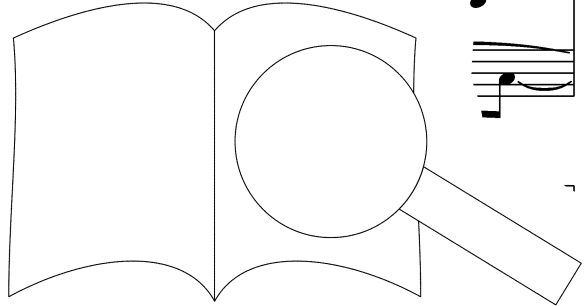

55

Musical score for measures 55-56. The system consists of three staves: a grand staff (treble and bass clefs) and a separate bass clef staff. Measure 55 features a complex melodic line in the treble clef with many sixteenth notes, while the bass clef staff has a simpler accompaniment. Measure 56 continues the melodic development.

57

Musical score for measures 57-58. Measure 57 shows a continuation of the melodic line in the treble clef. Measure 58 features a prominent five-fingered scale-like passage in the treble clef, indicated by a '5' above the staff. The bass clef staff provides harmonic support.

59

Musical score for measures 59-60. Measure 59 continues the melodic line in the treble clef. Measure 60 shows a change in the melodic pattern in the treble clef, with the bass clef staff continuing its accompaniment.

61

Musical score for measures 61-62. Measure 61 features a melodic line in the treble clef. Measure 62 shows a continuation of the melodic line in the treble clef, with the bass clef staff providing accompaniment.

PROBEPARTITUR

Ausgabequalität gegenüber Original evtl. gemindert • Evaluation Copy - Quality may be reduced • Carus-Verlag

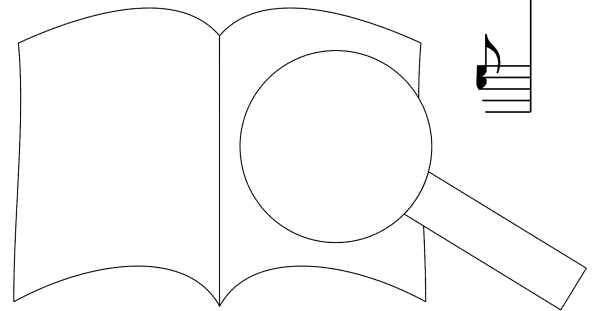

63

65

ritardando

ff (I. Man) I. Man II. Man **pp**

* 4

68

71

...ation der Takte 67, 70 und 77 siehe Kritischer Bericht, II. Orthografische Be
 ... Report, II. Orthografische Besonderheiten.

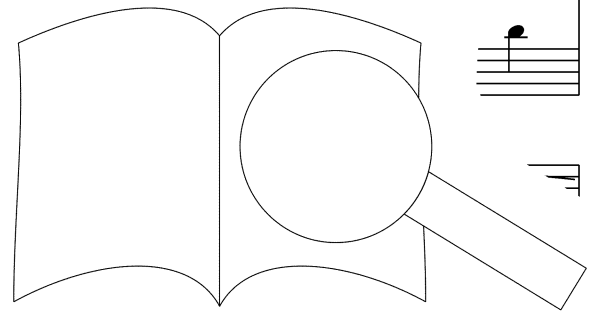

PROBEEPARTITUR

Ausgabequalität gegenüber Original evtl. gemindert • Evaluation Copy - Quality may be reduced • Carus-Verlag

74 (II. Man)

I. Man

I. Man 3

77

sempre *f*

80

83

PROBEPARTITUR

Ausgabequalität gegenüber Original evtl. gemindert • Evaluation Copy - Quality may be reduced • Carus-Verlag

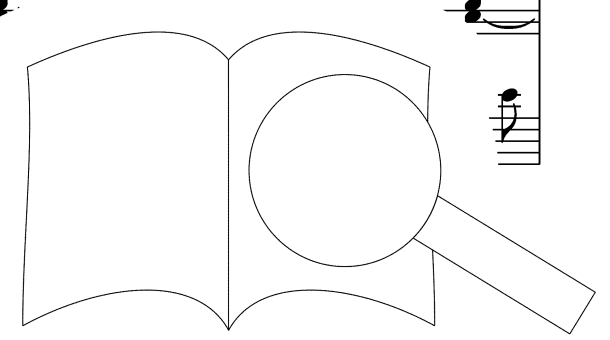

86

II. Man *p*

89

I. Man *f*

II. Man *p*

92

I. Man

96

I. Man *f*

PROBEPARTITUR

Ausgabequalität gegenüber Original evtl. gemindert • Evaluation Copy - Quality may be reduced • Carus-Verlag

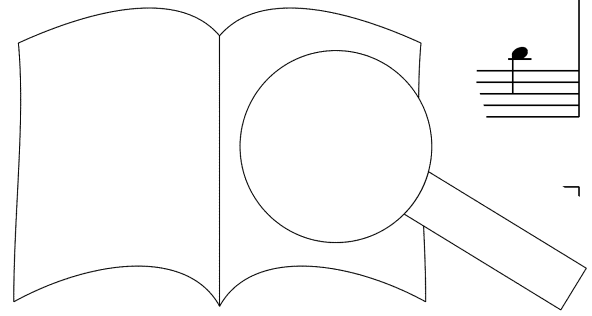

99

Musical score for measures 99-101. The system consists of three staves: a grand staff (treble and bass clefs) and a separate bass clef staff below. The music features a complex melodic line in the right hand with many beamed notes and a steady bass line in the left hand.

102

Musical score for measures 102-104. The system consists of three staves. A dynamic marking of *ff* (fortissimo) is present in the right hand. The music continues with intricate melodic patterns and a consistent bass accompaniment.

105

Musical score for measures 105-107. The system consists of three staves. The right hand features a triplet of eighth notes in measure 107. The bass line continues with a steady eighth-note accompaniment.

108

Musical score for measures 108-110. The system consists of three staves. The right hand has a *ritardando* marking. The left hand includes a section labeled "Jrgan" (likely organ) with a specific chord. The music concludes with a final cadence.

PROBEPARTITUR
 Ausgabequalität gegenüber Original evtl. gemindert • Evaluation Copy - Quality may be reduced • Carus-Verlag

Nr. 3 Fuge

[I. Man] 8', 4'

von der Takte 10, 19, 73, 84 und 86 siehe Kritischer Bericht, II. Orthografie
ne Critical Report, II. Orthografische Besonderheiten.

14

Musical score for measures 14-16. The piece is in G major (one sharp) and 3/4 time. Measure 14 features a treble clef with a half note G4, a quarter note A4, and a quarter note B4. The bass clef has a half note G3, a quarter note A3, and a quarter note B3. Measure 15 continues with similar patterns. Measure 16 has a treble clef with a half note G4, a quarter note A4, and a quarter note B4, and a bass clef with a half note G3, a quarter note A3, and a quarter note B3.

17

Musical score for measures 17-18. Measure 17 has a treble clef with a half note G4, a quarter note A4, and a quarter note B4. The bass clef has a half note G3, a quarter note A3, and a quarter note B3. Measure 18 has a treble clef with a half note G4, a quarter note A4, and a quarter note B4, and a bass clef with a half note G3, a quarter note A3, and a quarter note B3.

19

Musical score for measures 19-20. Measure 19 has a treble clef with a half note G4, a quarter note A4, and a quarter note B4. The bass clef has a half note G3, a quarter note A3, and a quarter note B3. Measure 20 has a treble clef with a half note G4, a quarter note A4, and a quarter note B4, and a bass clef with a half note G3, a quarter note A3, and a quarter note B3.

21

Musical score for measures 21-22. Measure 21 has a treble clef with a half note G4, a quarter note A4, and a quarter note B4. The bass clef has a half note G3, a quarter note A3, and a quarter note B3. Measure 22 has a treble clef with a half note G4, a quarter note A4, and a quarter note B4, and a bass clef with a half note G3, a quarter note A3, and a quarter note B3.

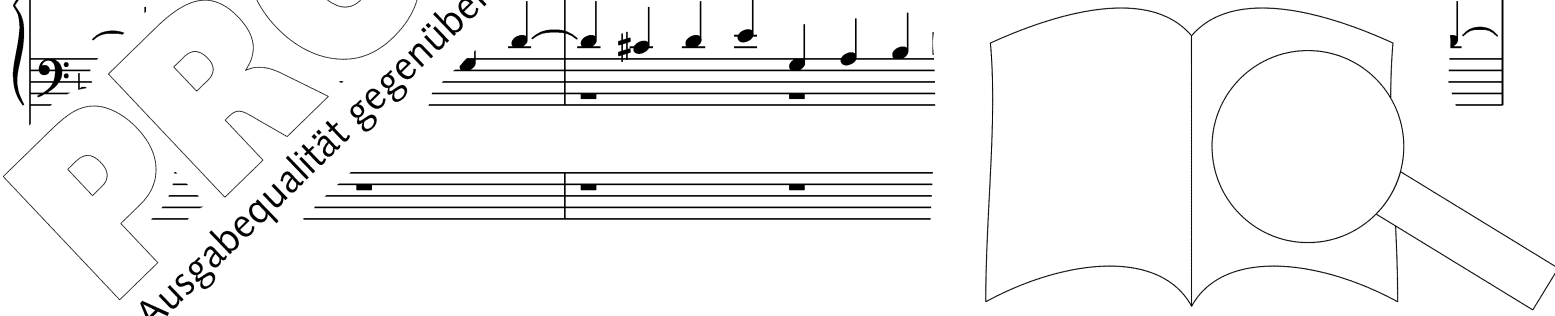

24

27

30

33

PROBEPARTITUR

Ausgabequalität gegenüber Original evtl. gemindert • Evaluation Copy - Quality may be reduced • Carus-Verlag

36

Musical score for measures 36-38. Treble clef, bass clef, and a third staff. Measure 36 has a triplet in the bass. Measure 38 has a triplet in the treble.

39

Musical score for measures 39-40. Treble clef, bass clef, and a third staff.

41

Musical score for measures 41-42. Treble clef, bass clef, and a third staff.

44

Musical score for measures 44-45. Treble clef, bass clef, and a third staff. Measure 45 has a triplet in the bass.

PROBEPARTITUR

Ausgabequalität gegenüber Original evtl. gemindert • Evaluation Copy - Quality may be reduced • Carus-Verlag

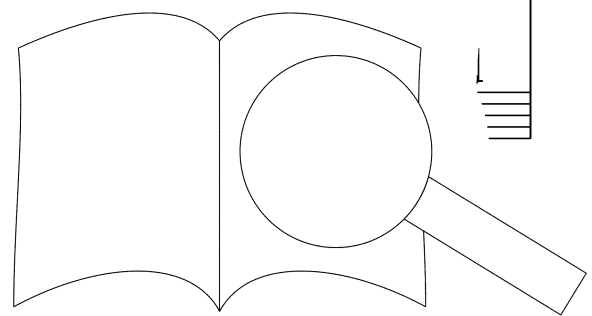

47

Musical score for measures 47-48. The system consists of three staves: a grand staff (treble and bass clefs) and a separate bass clef staff below. Measure 47 features a treble staff with a melodic line and a bass staff with a triplet of eighth notes. Measure 48 continues the melodic line in the treble and has a triplet of eighth notes in the bass staff.

49

ri - - - tar - - - dan - - - do

Musical score for measures 49-51. The system consists of three staves. Measure 49 has a treble staff with a melodic line and a bass staff with a rhythmic accompaniment. Measure 50 continues the melodic line in the treble and the accompaniment in the bass. Measure 51 concludes the phrase with a final note in the treble and a sustained note in the bass.

52 II. Man

p II. Man *p*

Musical score for measures 52-54. The system consists of three staves. Measure 52 is marked 'II. Man' and 'p' (piano). The treble staff has a melodic line, and the bass staff has a rhythmic accompaniment. Measure 53 continues the melodic line in the treble and the accompaniment in the bass. Measure 54 concludes the phrase with a final note in the treble and a sustained note in the bass.

55

Musical score for measures 55-56. The system consists of three staves. Measure 55 has a treble staff with a melodic line and a bass staff with a rhythmic accompaniment. Measure 56 continues the melodic line in the treble and the accompaniment in the bass.

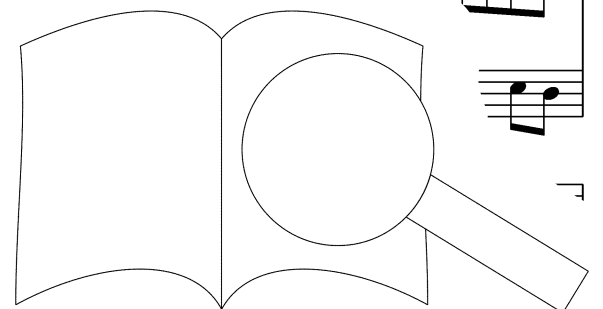

58

crescendo

This system contains measures 58 and 59. It features a grand staff with a treble and bass clef. The right hand has a complex melodic line with many accidentals, while the left hand provides a steady bass line. A *crescendo* marking is placed above the right hand in measure 59.

60

f

This system contains measures 60 and 61. The right hand begins with a forte (*f*) dynamic. The music continues with intricate melodic patterns in both hands.

62

This system contains measures 62 and 63. The right hand features a melodic line with a slur over measures 62-63, and the left hand continues with a rhythmic accompaniment.

64

This system contains measures 64 and 65. The right hand has a melodic line with a slur over measures 64-65, and the left hand provides a bass line.

PROBEEPARTITUR

Ausgabequalität gegenüber Original evtl. gemindert • Evaluation Copy - Quality may be reduced • Carus-Verlag

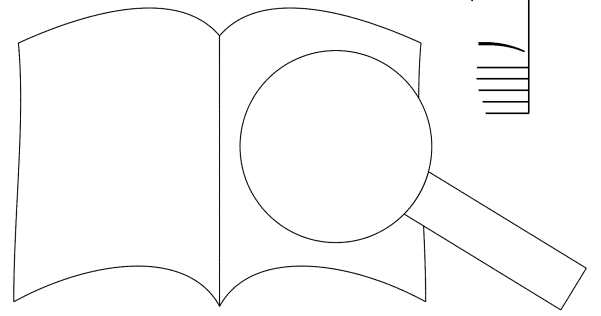

67 I. Man

I. Man *f* *crescendo*

69 *allargando*

allargando

71 *ff*

ff

72 *

* 5

ation dieses und des folgenden Taktes in der Stichvorlage und im Erstdruck
 neasure in the engraver's copy and the first edition, see the Critical Report.

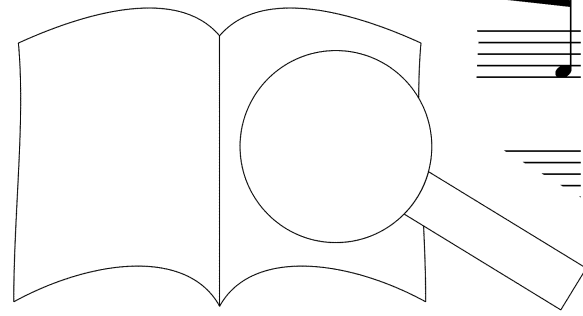

3

(73)

ritardando

Musical score for measures 73-74. Measure 73 features a complex piano accompaniment with a treble clef staff containing sixteenth-note patterns and a bass clef staff with chords. Measure 74 continues the piano accompaniment. A large watermark 'PROBE PARTITUR' is overlaid diagonally across the page.

74

II. Man *p*

Musical score for measure 74. The treble clef staff shows a melodic line with a triplet of eighth notes. The bass clef staff has a single note. A large watermark 'PROBE PARTITUR' is overlaid diagonally across the page.

75

Musical score for measure 75. The treble clef staff shows a melodic line with a triplet of eighth notes. The bass clef staff has a single note. A large watermark 'PROBE PARTITUR' is overlaid diagonally across the page.

76

Adagio

I. Mar *f*

allargando

5

Musical score for measure 76. The treble clef staff shows a melodic line with a quintuplet of eighth notes. The bass clef staff has a single note. A large watermark 'PROBE PARTITUR' is overlaid diagonally across the page.

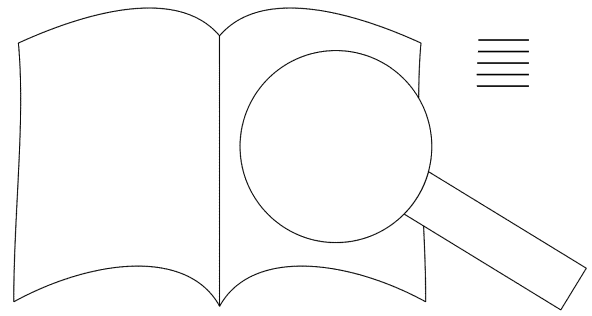

(77) *ff*

80

82

84

PROBEPARTITUR
Ausgabequalität gegenüber Original evtl. gemindert • Evaluation Copy - Quality may be reduced • Carus-Verlag

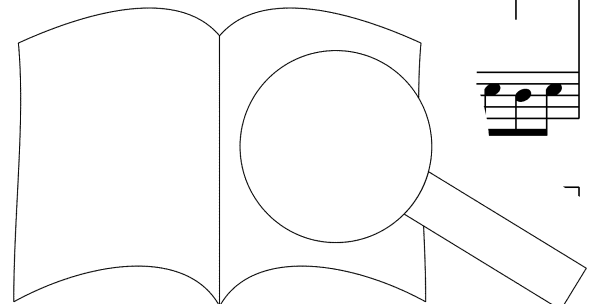

86

3

88

3

91 **Adagissimo**

Full Organ

3

95

ritardando

ritardando

PROBE-PARTITUR
Ausgabequalität gegenüber Original evtl. gemindert • Evaluation Copy - Quality may be reduced • Carus-Verlag 