

Josef Gabriel

RHEINBERGER

Orgelsonate Nr. 15 in D-Dur

Organ sonata in D major
op. 168

herausgegeben von / edited by
Martin Weyer

Einzelausgabe aus Band 39 der Gesamtausgabe (Orgelsonaten)
Separate edition from volume 39 of the Complete Works (Organ Sonatas)

Sämtliche Werke · Complete Works



Carus 50.168

Inhalt

Orgelsonate Nr. 15 in D-Dur op. 168

I. Phantasie	3
II. Adagio	14
III. Introduction und Ricercare	18

Das Werk der vorliegenden Ausgabe ist Band 39 der Rheinberger-Gesamtausgabe entnommen. Für das Vorwort und den Kritischen Bericht verweisen wir auf die Gesamtausgabe.

Rheinbergers Orgelmusik erscheint in der Gesamtausgabe in drei Bänden und einem Supplementband:
Band 38: Orgelmusik I (Orgelsonaten 1–10) (Carus 50.238)
Band 39: Orgelmusik II (Orgelsonaten 11–20) (Carus 50.239)
Band 40: Orgelmusik III (Kleinere Orgelwerke) (Carus 50.240)
Supplementband 3: Kleinere Orgelwerke ohne Opuszahl (Auswahl) (Carus 50.288)

The work of this edition is taken from Vol. 39 of the Complete Edition of the Works of Josef Gabriel Rheinberger.
For the Foreword and the Critical Report please refer to the Complete Edition.

Rheinberger's organ music is published in the Complete Edition in three volumes and one supplementary volume:
Vol. 38: Organ music I (Organ sonatas 1–10) (Carus 50.238)
Vol. 39: Organ music II (Organ sonatas 11–20) (Carus 50.239)
Vol. 40: Organ music III (Smaller organ works) (Carus 50.240)
Supplementary volume 3: Smaller organ works without opus numbers (a selection) (Carus 50.288)

Aufführungsdauer / Duration: ca. 24 min.
© 1992 / 2019 Carus-Verlag, Stuttgart – Carus 50.168
Vervielfältigungen jeglicher Art sind gesetzlich verboten.
Any unauthorized reproduction is prohibited by law.
Alle Rechte vorbehalten / All rights reserved
Printed in Germany

Sonate Nr. 15 in D-Dur

I. Phantasie

Josef Gabriel Rheinberger, op. 168 (1891)

Andante amabile ♩ = 138

Manual

Pedal

Anm

rk.
erk ohne Mixturen.
al 8' oder volles
Manual.

p = e
pp = c
ppp = d
I

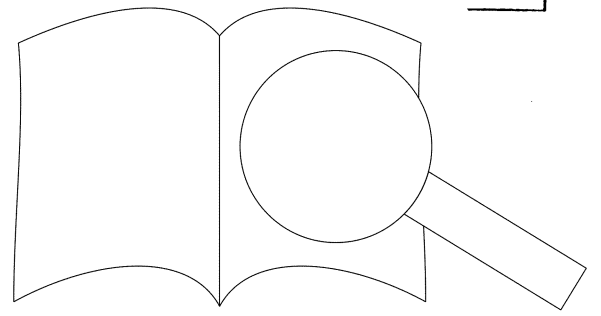

17 *rit. - - - a tempo*

p

21 *mf*

mf

25 *p*

p

29

PROBEEPARTHEUR
Ausgabequalität gegenüber Original evtl. gemindert • Evaluation Copy - Quality may be reduced • Carus-Verlag

33

mf

38

42

rit.

rit.

sf

47

51

54

57

61

PROBEPARTITUR

Ausgabequalität gegenüber Original evtl. gemindert • Evaluation Copy - Quality may be reduced • Carus-Verlag

65

70

75

79

rit.

84 *a tempo*

mf

mf

3

90

96

rit.

102 *a tempo*

PROBEPARTITUR

Ausgabequalität gegenüber Original evtl. gemindert • Evaluation Copy - Quality may be reduced • Carus-Verlag

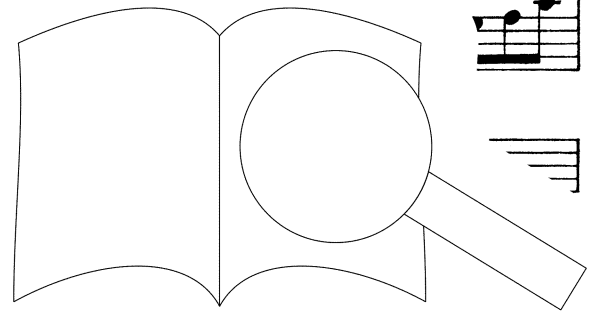

106

Musical score for measures 106-108. The top staff features a melodic line with triplets and slurs. The middle and bottom staves provide harmonic accompaniment with chords and bass lines.

109

Musical score for measures 109-112. The top staff continues the melodic line with slurs and ties. The middle and bottom staves continue the harmonic accompaniment.

113

rit. - - a tempo

ff

Musical score for measures 113-116. Measure 113 includes a tempo change from 'rit.' to 'a tempo' and a dynamic marking of 'ff'. The top staff has a melodic line with slurs. The middle and bottom staves provide harmonic accompaniment.

117

Musical score for measures 117-120. The top staff features a melodic line with slurs. The middle and bottom staves provide harmonic accompaniment.

PROBEPARTITUR

Ausgabequalität gegenüber Original evtl. gemindert • Evaluation Copy - Quality may be reduced • Carus-Verlag

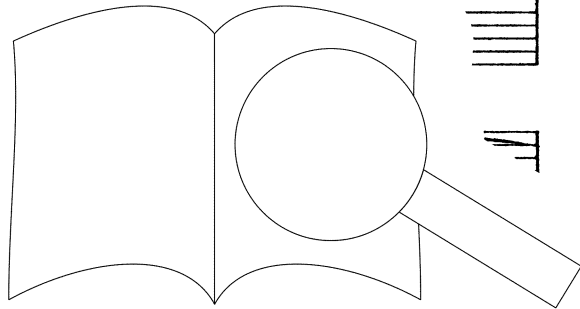

121

125

130

135

PROBEPARTITUR
Ausgabequalität gegenüber Original evtl. gemindert • Evaluation Copy - Quality may be reduced • Carus-Verlag

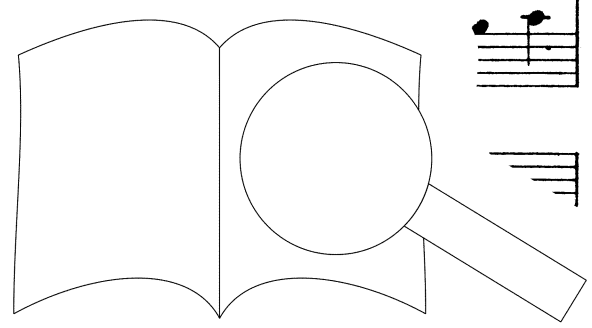

140

145

rit. - - - - *a tempo*

149

153

PROBEPARTITUR

Ausgabequalität gegenüber Original evtl. gemindert • Evaluation Copy - Quality may be reduced • Carus-Verlag

156

162

168

173

178

PROBENPARTITUR
Ausgabequalität gegenüber Original evtl. gemindert • Evaluation Copy - Quality may be reduced • Carus-Verlag

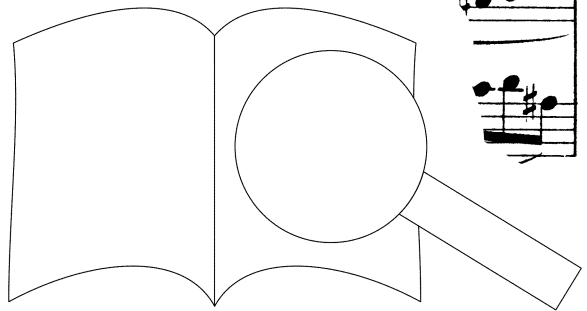

183

189

194

198

204

poco a poco rit.

PROBENPARTITUR
Ausgabequalität gegenüber Original evtl. gemindert • Evaluation Copy - Quality may be reduced • Carus-Verlag

II.

Adagio ♩ = 58

p espressivo

pp

mf

p

p

PROBENPARTIE
Ausgabequalität gegenüber Original evtl. gemindert • Evaluation Copy - Quality may be reduced • Carus-Verlag

19

22

25

28

PROBEPARTITUR
Ausgabequalität gegenüber Original evtl. gemindert • Evaluation Copy - Quality may be reduced • Carus-Verlag

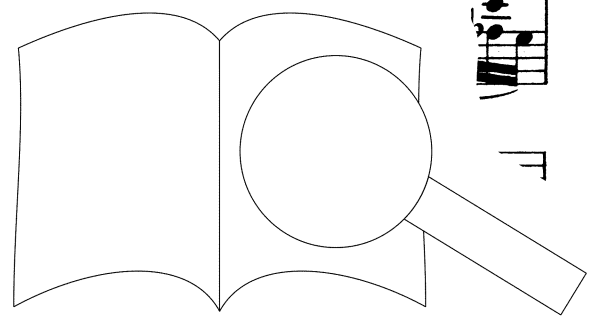

31

Musical score for measures 31-33. Treble clef, bass clef, and a separate bass line. Includes slurs and dynamic markings.

34

Musical score for measures 34-36. Treble clef, bass clef, and a separate bass line. Includes slurs, dynamic markings (*mf*, *p*), and a watermark.

37

Musical score for measures 37-39. Treble clef, bass clef, and a separate bass line. Includes slurs, dynamic markings (*pp*), and a watermark.

41

Musical score for measures 41-43. Treble clef, bass clef, and a separate bass line. Includes slurs and a watermark.

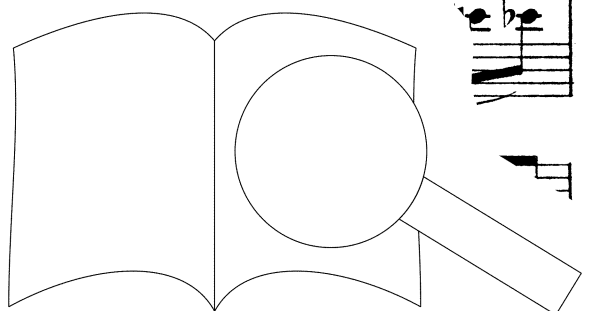

45

f *mf* *p*

rit. *a tempo*

50

pp *ff*

rit. *a tempo*

54

p *mf*

a tempo

57

pp

molto rit.-

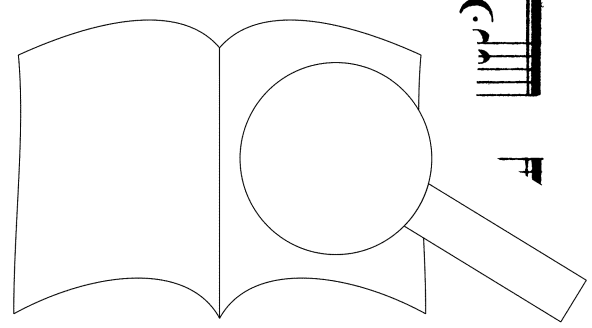

PROBEEPARTEUR

Ausgabequalität gegenüber Original evtl. gemindert • Evaluation Copy - Quality may be reduced • Carus-Verlag

III. Introduction und Ricercare

Maestoso ♩ = 63

Musical notation for measures 1-3. The score is in G minor (three flats) and common time. It features a complex texture with multiple voices in both hands, including sixteenth-note patterns and sustained chords. A dynamic marking of *f* is present at the beginning.

Musical notation for measures 4-7. The texture continues with intricate rhythmic patterns and harmonic development. A dynamic marking of *f* is also present.

Musical notation for measures 8-10. The piece continues with dense polyphonic textures. A dynamic marking of *f* is present.

Musical notation for measures 11-13. The notation includes a key signature change to G major (one sharp) at measure 11. The texture remains complex and rhythmic.

PROBEEPARTITUR
Ausgabequalität gegenüber Original evtl. gemindert • Evaluation Copy - Quality may be reduced • Carus-Verlag

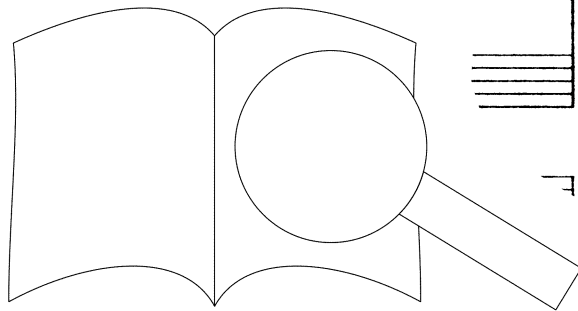

14 *poco animato*

mf *f*

mf

18

ff *ff*

22

f *f*

26

f *f*

30

f *f*

PROBEPARTITUR
Ausgabequalität gegenüber Original evtl. gemindert • Evaluation Copy - Quality may be reduced • Carus-Verlag

Con moto $\text{♩} = 63$

37

Musical notation for measures 37-39. The piece is in G major (one sharp) and 3/4 time. The tempo is 'Con moto' with a quarter note equal to 63 beats per minute. The dynamic is 'ff' (fortissimo). The notation includes a treble clef and a bass clef. Measure 37 starts with a half note G4. Measure 38 has a half note A4. Measure 39 has a half note B4. There are various ornaments and slurs throughout.

Musical notation for measures 40-45. The notation continues with a treble clef and a bass clef. Measure 40 starts with a half note C5. Measure 41 has a half note D5. Measure 42 has a half note E5. Measure 43 has a half note F5. Measure 44 has a half note G5. Measure 45 has a half note A5. There are various ornaments and slurs throughout.

Musical notation for measures 46-51. The notation continues with a treble clef and a bass clef. Measure 46 starts with a half note B4. Measure 47 has a half note C5. Measure 48 has a half note D5. Measure 49 has a half note E5. Measure 50 has a half note F5. Measure 51 has a half note G5. There are various ornaments and slurs throughout.

Musical notation for measures 52-57. The notation continues with a treble clef and a bass clef. Measure 52 starts with a half note A5. Measure 53 has a half note B5. Measure 54 has a half note C6. Measure 55 has a half note D6. Measure 56 has a half note E6. Measure 57 has a half note F6. There are various ornaments and slurs throughout.

Musical notation for measures 58-63. The notation continues with a treble clef and a bass clef. Measure 58 starts with a half note G6. Measure 59 has a half note A6. Measure 60 has a half note B6. Measure 61 has a half note C7. Measure 62 has a half note D7. Measure 63 has a half note E7. There are various ornaments and slurs throughout.

PROBENPARTITUR
Ausgabequalität gegenüber Original evtl. gemindert • Evaluation Copy - Quality may be reduced • Carus-Verlag

64

70

76

82

88

PROBEPARTITUR
Ausgabequalität gegenüber Original evtl. gemindert • Evaluation Copy - Quality may be reduced • Carus-Verlag

94

Musical notation for measures 94-99. Treble and bass staves with piano accompaniment.

100

Musical notation for measures 100-104. Treble and bass staves with piano accompaniment.

105

Musical notation for measures 105-109. Treble and bass staves with piano accompaniment.

110

mezzo

Musical notation for measures 110-115. Treble and bass staves with piano accompaniment. The dynamic marking *mezzo* is present above the treble staff.

116

mf

Musical notation for measures 116-119. Treble and bass staves with piano accompaniment. The dynamic marking *mf* is present below the bass staff.

PROBEPARTITUR

Ausgabequalität gegenüber Original evtl. gemindert • Evaluation Copy - Quality may be reduced • Carus-Verlag

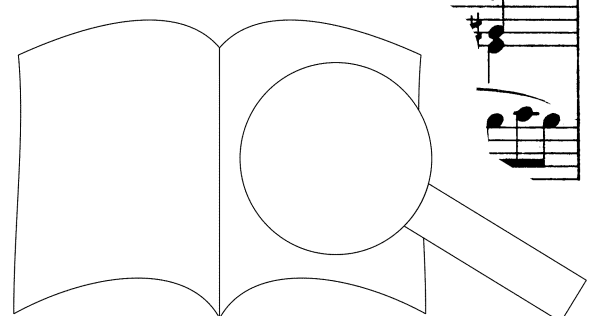

120

124

128

132

136

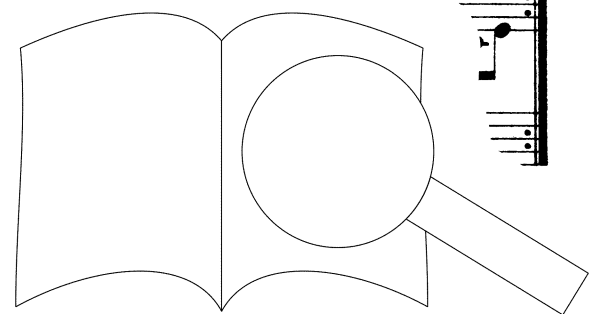

PROBENPARTI FÜR
Ausgabequalität gegenüber Original evtl. gemindert • Evaluation Copy - Quality may be reduced • Carus-Verlag

140

143

146

150

154

PROBEPARTITUR
Ausgabequalität gegenüber Original evtl. gemindert • Evaluation Copy - Quality may be reduced • Carus-Verlag

Ricercare

158

Musical score for measures 158-164. The score is written for piano and features a complex, rhythmic melody in the right hand and a supporting bass line in the left hand. The key signature is one sharp (F#) and the time signature is 3/4.

165

Musical score for measures 165-170. The score is written for piano and features a complex, rhythmic melody in the right hand and a supporting bass line in the left hand. The key signature is one sharp (F#) and the time signature is 3/4. A dynamic marking of *ff* (fortissimo) is present.

171

Musical score for measures 171-176. The score is written for piano and features a complex, rhythmic melody in the right hand and a supporting bass line in the left hand. The key signature is one sharp (F#) and the time signature is 3/4.

177

Musical score for measures 177-182. The score is written for piano and features a complex, rhythmic melody in the right hand and a supporting bass line in the left hand. The key signature is one sharp (F#) and the time signature is 3/4.

183

Musical score for measures 183-188. The score is written for piano and features a complex, rhythmic melody in the right hand and a supporting bass line in the left hand. The key signature is one sharp (F#) and the time signature is 3/4.

PROBEPARTITUR
Ausgabequalität gegenüber Original evtl. gemindert • Evaluation Copy - Quality may be reduced • Carus-Verlag

188

Musical score for measures 188-192. The score is written for piano in G major (one sharp) and 4/4 time. It features a complex texture with multiple voices in both hands, including sixteenth-note passages and sustained chords.

193

Musical score for measures 193-197. The texture continues with intricate melodic lines and harmonic support. A large watermark 'PROBE PARTITUR' is visible across the page.

198

Musical score for measures 198-202. The music shows a continuation of the complex rhythmic and harmonic patterns. A watermark 'PROBE PARTITUR' is visible across the page.

203

Musical score for measures 203-207. The tempo marking **Maestoso** is present above the staff. The music features a prominent melodic line in the right hand. A watermark 'PROBE PARTITUR' is visible across the page.

208

Musical score for measures 208-212. The tempo marking *rit.* (ritardando) is present above the staff. The music concludes with a final melodic flourish. A watermark 'PROBE PARTITUR' is visible across the page.

PROBE PARTITUR
 Ausgabequalität gegenüber Original evtl. gemindert • Evaluation Copy - Quality may be reduced • Carus-Verlag

Andante molto

213

Musical score for measures 213-218. The piece is in G major and 3/4 time. It features a piano introduction with dynamics *p* and *pp*. The right hand has a melodic line with grace notes, while the left hand provides harmonic support with chords and moving bass lines.

219

rit. **Maestoso** ♩ = 120

Musical score for measures 219-222. The tempo changes to **Maestoso** with a metronome marking of ♩ = 120. The piece is in 4/4 time. Dynamics include *pp* and *ff*. The right hand features a melodic line with grace notes, and the left hand has a rhythmic accompaniment.

223

Musical score for measures 223-225. The piece continues in 4/4 time. The right hand has a melodic line with grace notes, and the left hand has a rhythmic accompaniment.

226

Musical score for measures 226-228. The piece continues in 4/4 time. The right hand has a melodic line with grace notes, and the left hand has a rhythmic accompaniment.

229

rit.

Musical score for measures 229-231. The piece continues in 4/4 time. The right hand has a melodic line with grace notes, and the left hand has a rhythmic accompaniment. The score ends with a double bar line and repeat dots.

PROBEPARTITUR

Ausgabequalität gegenüber Original evtl. gemindert • Evaluation Copy - Quality may be reduced • Carus-Verlag

Orgel solo / Organ solo

Bach: Fantasia e Fuga in c, BWV 562	40.594/10
Bach: Sonate in C nach BWV 1005 (arr. Bornefeld)	29.177
- Partita in d nach BWV 1004 (arr. Bornefeld)	29.179
Bartók: Suite für Orgel (arr. Bornefeld)	29.174
Bezler: Biblia Organi. 13 Orgelbilder (Perc ad lib.)	18.069
Bornefeld: Orgelsonate 1965/66	29.105
Danziger Orgelmusik des 16.–18. Jahrhunderts	28.003
Das rote Album. Hits for Organ I	18.062
Freie Orgelmusik der Romantik I, II und III (Vökl)	40.591–593
Französische Orgelmusik des 19. Jhds	91.225
Froberger: Toccaten u. Fantasia	91.075
Fugen des 19. Jahrhunderts (2 Bde)	91.228/9
Hindemith: Pastorale, Fuge, Postludium (arr. Bornefeld)	29.152/10
Husumer Orgelbuch (Sammlung, 1758)	18.053
Janca: Manchmal kennen wir Gottes Willen (1992)	18.109
- Kleine Toccata über „Hört, der Engel helle Lieder“ (1995)	18.108
Karkoschka: Toccata und Fuge über 2 Osterchoräle (1953)	18.057
Krebs: Choralbearbeitungen (Erster Teil der Clavier-Übung)	18.524
Mozart: 17 Kirchensonaten (arr. für Orgel solo)	18.067
Muffat: Apparatus musico-organisticus	91.071
Murschhauser: Octi-Tonium Novum Organicum	91.074
Musik zu Kasualien 4 (für Orgel allein)	2.079
Norddt. Orgelmusik 1780–1860 (3 Bde)	18.026/10–30
Ochsenhauser Orgelbuch (1735) (Faksimile und Notenteil)	24.409
Österliche süddt. Orgelmusik (15.–19. Jh.)	92.372
Organo pleno. 140 Stücke zum Ein- und Ausgang (17./18. Jh.)	18.074
Orgelbuch Mozart-Haydn (L. + W. A. Mozart, J. + J. M. Haydn)	2.118
Orgelmusik aus Europa (7 Bde)	91.230–36
Orgelmusik der Familie Hasse (17. Jh.)	18.077
Orgelstücke der Orgelschule Wegweiser (Augsburg 1668)	91.076
Orgelwerke der Spätromantik	91.224
Orgelwerke des 16.–18. Jhds (Laukvik, Orgelschule)	40.511
Pastorale 1: 47 Pastoralkomp., CH, F, GB, I (17./18. Jh.)	18.081
Pastorale 2: 64 Pastoralkomp., D, A, Böhmen, S-Tirol (18. Jh.)	18.082
Peyer: Praebuli e Fughe (2 Bde)	91.081/2
Praetorius, J.: Drei Praeambula, Magnificat-Bearbeitungen	18.003
Regger: Werkausgabe, mit DVD, Abt. I/1: Choralphantasien	52.801
Abt. I/2: Phantasien u. Fugen, Variationen, Sonaten, Suiten I	52.802
Abt. I/3: Phantasien u. Fugen, Variationen, Sonaten, Suiten II	52.802 ²
Abt. I/4: Choralvorspiele	52.803
Abt. I/5–7: Orgelstücke I–III	52.805–7
Rheinberger: Orgelsonaten 1–10. Band 38 der GA (Ln)	18.102
- Orgelsonaten 11–20. Band 39 der GA (Ln)	18.103
- Kleinere Orgelwerke. Band 40 der GA (Ln)	18.104
- Kleinere Orgelwerke ohne Opuszahl. Supplement zu	18.105
- Freie Orgelmusik für den Gottesdienst	18.106
Schroeder: Pezzi piccoli	18.107
Schumann: Toccata op. 7 (arr. Rothaupt)	18.108
Silcher: Sämtliche Orgelstücke	18.109
Vierne: Sämtliche Orgelwerke (13 Bd.)	18.110
Vogler: 32 Préludes pour l'Orgue	18.111

Vorspiele und Begleitsätze zu Preludes and hymn settings

Aphorismen, Intonationen	18.115
Aphorismen, Intonationen (II)	18.116
Bach, J. M.: Sämtliche Orgelstücke	30.650
Bach: Sechs Orgelstücke	18.021
- Sechs Choräle (arr. Bornefeld)	18.047
- 18 Choräle (arr. Bornefeld)	18.111
Bornemann: Orgelstücke	29.064 – 29.071
- Choralvorspiele	29.029 + 29.030
Bornemann: Orgelstücke des jungen Bach	18.114
Bornefeld: Orgelstücke des 19. Jahrhunderts	91.226
Bornefeld: Orgelstücke der Jahrhundertwende (19./20. Jh.)	91.227
Bornefeld: Orgelstücke „Gotteslob“, Bd. 1 (Advent/Weihn.)	18.202
Bornefeld: Orgelstücke „Gotteslob“, Bd. 2 (Bußzeit/Ostern)	18.203
Essi: Choralvorspiele, Intonationen, Vorspiele	18.112
Freiburger Orgelbuch	18.075
Freiburger Kantorenbuch (Antwortpsalmen)	19.035
Gerok: Kleine Choralvorspiele	18.117
Homilius: 32 Praeludia. Choralvorspiele für Orgel	37.107

Horn: 16 Choralvorspiele zum EG für Orgel	18.051
Intonationen zum „Gotteslob“	18.201
Merkel: Kurze und leichte Choralvorspiele	18.103
Oley: Sämtliche Choralvorspiele (2 Bde)	18.101/10
- 1: Choralvorspiele zum EG und GL	18.101/10
- 2: Orgelchoräle z. gottesd. u. konzertanten Gebrauch	18.101/20
Orgelbuch <i>light</i> zum „Gotteslob“ (3-stg), 2 Bde.	18.212
Orgelwerke über Themen des Gregor. Chorals	91.237
Rinck: Leichte Choralvorspiele op. 105	18.105
Schlenker: Leichte 3stg Begleitsätze zum EG-Stammteil	18.104
Stier: Choralvorspiele der Familie Stier	18.061
Württembergisches Orgelbuch (zum Regionalteil des EG)	18.100

Orgel mit 1 Melodieinstrument / Organ with 1 melody instrument

Bach: Drei Choralvorspiele (Eh) (arr. Bornefeld)	29.186
- Acht Choralbearbeitungen (arr. Bornefeld)	29.188
- Drei Choralvorspiele (Vc) (arr. Bornefeld)	29.193
Bornefeld: Bebuka (Marimbaphon)	29.122
- Choralsonate „Auf, auf, mein Herz“ (Tr)	29.075
- Lituus (Trb)	124
- Threni (Eh)	123
Busoni: Var. ü. d. Chorallied BWV 517 (VI) (arr. Bornefeld)	29.186
Homilius: Sämtliche Choralvorspiele für Orgel	37.107
- 1–2 obligate Melodieinstrumente, Sonaten	37.107
Kauffmann: Sechs vierstimmige Choräle	18.055
Krebs: Drei Fantasien (Blasinstr.)	18.524
- Freu dich sehr, o meine Seele (Tr)	18.055
- Vier Choralvorspiele (Blasinstr.)	18.055
Langlais: Supplicatio (= 1. Choralvorspiel) (VI)	584/50
Mozart: Andante und Fugue (arr. Bornefeld)	29.195
Oley: Wunderbar (arr. Bornefeld)	13.023
Purcell: Suite für Orgel	26.301
Raphael: Sonate (arr. Bornefeld)	16.004
Rheinberger: Sonate (arr. Bornefeld)	16.029
- Sechser (arr. Bornefeld)	50.150
- Sinfonie (arr. Bornefeld)	50.166/10
Rheinberger: Sonate (arr. Bornefeld)	16.043
Telemann: Sonate (arr. Bornefeld)	29.187
Telemann: Sonate (arr. Bornefeld)	13.003

Orgel mit 2–8 Instrumenten / Organ with 2–8 instruments

Bornefeld: Orgelsonaten 1–10. Band 38 der GA (Ln)	13.070
Bornefeld: Orgelsonaten 11–20. Band 39 der GA (Ln)	29.185
Bornefeld: Kleinere Orgelwerke. Band 40 der GA (Ln)	29.168
Bornefeld: Kleinere Orgelwerke ohne Opuszahl. Supplement zu	29.130
Bornefeld: Freie Orgelmusik für den Gottesdienst	11.208 + 13.014
Bornefeld: Choral médieval für Orgel und 6 Bläser	26.402
Bornefeld: Choral médieval für 2 Orgeln und 8 Bläser (4 Tr, 4 Trb, Timp)	40.586
Bornefeld: Gott des Himmels und der Erden (8 Harm)	13.025
Rheinberger: Suite in c (VI, Vc)	50.149

Orgelkonzerte / Organ concertos

Anonymus: Concertino a due Cembali (Orgel)	18.504
Bach, J. Chr.: Orgelkonzert in F	38.501
- Orgelkonzert in B	38.502
- Orgelkonzert in Es	38.503
Bach: Konzert in d BWV 1052 (arr. Bornefeld)	29.197
Händel: Concerti d'organo Nr. 7–12	40.538
- Concerti d'organo Nr. 13–16	40.545
Rheinberger: Orgelkonzert Nr. 1 in F op. 137	50.137
- Orgelkonzert Nr. 2 in g op. 177	50.177
Rentzsch: Orgelkonzert (1984)	18.065

Orgelschulen, Bücher / Organ schools, books

Gaar: Orgelimprovisation	4.017
Latry/Mallié: L'oeuvre d'orgue	1.118
Laukvik: Orgelschule zur I. Orgel	40.511
- Bd. 1: Barock und Klassik	40.511
- Part 1: Baroque and Classic	40.511
- Bd. 2: Romantik	40.512
- Part 2: The Romantic Era (19. Jh.)	40.512
- Bd. 3: Die Moderne	40.513
Schildknecht/Schröder: Orgelschule	40.514
Vökl: Orgeln in Württemberg (150 Farbtafeln)	24.014
Wolff/Zepf: Die Orgeln J. S. Bachs	24.045

