

Franz
SCHUBERT

Messe in Es

Mass in E flat major
D 950

per Soli (SATTB), Coro (SSATTBB)
2 Oboi, 2 Clarinetti, 2 Fagotti
2 Corni, 2 Clarini, 3 Tromboni, Timpani
2 Violini, Viola, Violoncello, Contrabbasso

herausgegeben von / edited by
Werner Bodendorff

Stuttgarter Schubert-Ausgaben · Urtext

Klavierauszug / Vocal score
Paul Horn



Carus 40.660/03

Messe in Es

D 950

Franz Schubert

1797–1828

Kyrie

Klavierauszug: Paul Horn

Andante con moto, quasi Allegretto

Soprano

Alto

Tenore

Basso

2 Oboi
2 Clarinetten
2 Fagotti
2 Corni
3 Tromboni
Archi
Bassi

Legni, Ottoni

Bassi

The musical score is presented in a multi-staff format. The vocal parts (Soprano, Alto, Tenore, Basso) are written in treble clef with a key signature of two flats and a 3/4 time signature. The instrumental parts include woodwinds (Oboes, Clarinets, Bassoons, Horns, Trombones) and strings (Archi, Basses). The score includes dynamic markings such as *pp* and *fp*. The lyrics are written below the vocal staves, starting with "Kyrie eleison". The score is marked with a large "PROBE" watermark and a diagonal watermark that reads "Evaluation Copy - Quality may be reduced".

18

son, Ky - ri -

son, Ky - ri -

son, Ky - ri -

son, Ky - ri -

Ob, Clt

Fag, Trb

24

e - e - le - - - i - son,

e e - lei - - - son,

e e - le - - - i - son,

e e - lei - - - son

30

Ky - ri -

e - lei - - - son, Ky - ri -

e e - lei - - - son Ky - ri -

ri - e e - lei -

ri -

PROBEPARTITUR

Ausgabequalität gegenüber Original evtl. gemindert • Evaluation Copy - Quality may be reduced • Carus-Verlag

36

e e - lei - son, e lei - son, Ky - ri -

e e - lei - son, e lei - son, Ky - ri -

e e - lei - son, e lei - son, Ky - ri -

e e - lei - son, e lei - son, Ky - ri -

+ Ottoni

42

e e - lei - son, e - lei

e e - lei - son, e - lei

e e - lei - son, e - lei

e e - lei - son, e

48

Christe elei

Christe elei

Christe elei

Christe elei

Christe

cresc.

cresc.

cresc.

cresc.

cresc.

simile

cresc.

54 *cresc.* *ff* *p*
 son, e - lei - - - - - son, *ff* *p*
cresc. *ff* *p*
 son, e - lei - - - - - son, *ff* *p*
cresc. *ff* *p*
 son, e - lei - - - - - son, *ff* *p*
cresc. *ff* *p*
 son, e - lei - - - - - son, *ff* *p*
 Tutti

61 *cresc.* *f* *cresc.*
 Chri - ste e - lei - - son, *cresc.*
cresc. *f* *cresc.*
 Chri - ste e - lei - - son, *cresc.*
cresc. *f* *cresc.*
 Chri - ste e - lei - - son, *cresc.*
cresc. *f* *cresc.*
 Chri - ste e - lei - - son, *cresc.*

69 *ff* *ff* *ff*
 son, ste, Chri - ste e - lei *ff*
ff *ff* *ff*
 son, ste e - lei - - - *ff*
ff *ff* *ff*
 son, ste *ff*
 Chri - ste

PROBENPARTITUR
 Ausgabegleichheit gegenüber Original evtl. gemindert • Evaluation Copy - Quality may be reduced • Carus-Verlag

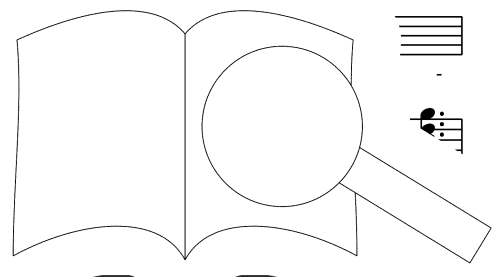

son, e - lei - - son, e - lei - - son.

son, e - lei - - son, e - lei - - son.

son, e - lei - - son, e - lei - - son.

son, e - lei - - son, e - lei - - son.

- Ottoni

decresc.

p

pp

pp

pp

lei - - son, e - lei - - son.

lei - - son, e - lei - - son

ri - e,

Cor >

pp

decresc.

pp

pp

pp

Ky - ri

Ky

son, e - lei - - son,

lei - - son, e - lei - - son,

e - lei - - son,

e - lei - - son,

e - lei - - son,

gni

fp

PROBEPARTITUR

Evaluation Copy - Quality may be reduced.

Carus-Verlag

Ausgabequalität gegenüber Original evtl. gemindert

97

p Ky - ri - e e -

p Ky - ri - e e -

p Ky - ri - e e -

p Ky - ri - e e -

Fag, Trb

VI

103

lei - - - son,

lei - - - son,

lei - - - son,

lei - - - son,

Legni, Trb

108

e - lei - - - son,

e - lei - - - son,

ri - e e - lei - - - son,

ri - e e

n,

PROBEPARTITUR

Ausgabequalität gegenüber Original evtl. gemindert • Evaluation Copy - Quality may be reduced • Carus-Verlag

113

fp

Ky - - ri - e e - lei - - son, e - lei - - son,

fp

Ky - - ri - e e - lei - - son, e - lei - - son,

fp

Ky - - ri - e e - lei - - son, e - lei - - son,

fp

Ky - - ri - e e - lei - - son, e - lei - - son,

119

fp *pp*

Ky - - ri - e e - lei - - son, e - lei

fp *pp*

Ky - - ri - e e - lei - - son, e

fp

Ky - - ri - e e - lei - - son,

fp

Ky - - ri - e e - lei

125

son,

- son,

- son,

- son,

Cor, Fag

PROBEPARTITUR

Ausgabequalität gegenüber Original evtl. gemindert • Evaluation Copy - Quality may be reduced • Carus-Verlag

130

Musical score for voices and piano, measures 130-134. The vocal parts (Soprano, Alto, Tenor, Bass) sing "Ky - ri - e, e -". The piano accompaniment features a rhythmic pattern of eighth notes in the right hand and chords in the left hand. Dynamics include *p* and *ff*. A *Tutti* marking appears at the start of measure 134.

135

Musical score for voices and piano, measures 135-140. The vocal parts sing "lei". The piano accompaniment continues with the rhythmic pattern. Dynamics include *p*, *cresc.*, and *sc.*. A *Vc* marking is present in the piano part.

141

Musical score for voices and piano, measures 141-145. The vocal parts sing "son, e lei". The piano accompaniment continues with the rhythmic pattern. Dynamics include *p*. A large graphic of a magnifying glass is overlaid on the bottom right of the page.

PROBEPARTITUR
 Ausgabequalität gegenüber Original evtl. gemindert • Evaluation Copy - Quality may be reduced • Carus-Verlag

147

son, Ky - ri -

son, Ky - ri -

son, Ky - ri -

son, Ky - ri -

pp Cor, Fag *decresc.*

152

e, Ky - ri - e e - lei

e, Ky - ri - e e - lei

e, Ky - ri - e e - lei

e, Ky - ri - e e - lei

ff *p* *ff* *p* *ff* *p* *ff* *p* *ff* *p* *ff* *p*

ff *pp*

Tutti

158

e - lei - son.

e - lei - son.

e

PROBEPARTITUR
Ausgabequalität gegenüber Original evtl. gemindert • Evaluation Copy - Quality may be reduced • Carus-Verlag

Gloria

Allegro moderato e maestoso

Soprano
Alto
Tenore
Basso

Glo - ri - a in ex - cel - sis De - o, glo - ri - a in ex -
Glo - ri - a in ex - cel - sis De - o, glo - ri - a in ex -
Glo - ri - a in ex - cel - sis De - o, glo - ri - a in ex -
Glo - ri - a in ex - cel - sis De - o, glo - ri - a in ex -

2 Oboi
2 Clarinetti
2 Fagotti
2 Corni
2 Clarini
3 Tromboni
Timpani
Archi
Bassi

Vl Tutti

6

cel - sis, glo - ri - a in ex - cel - sis, glo - ri - a in ex -
cel - sis, glo - ri - a in ex - cel - sis, glo - ri - a in ex -
cel - sis, in ex - cel - sis, in ex -
cel - sis, glo - ri - a in ex - cel - sis, glo - ri - a in ex -

Archi +Legni

12

cel - sis, De - o.
cel - sis De - o.
cel - sis De - o.
ex - cel - sis De - o.

Tutti

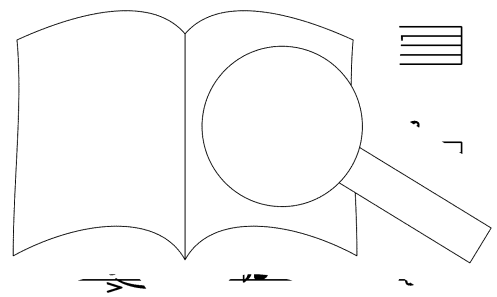

p Et in ter - ra pax, pax ho-mi - ni - bus bo - nae vo-lun - ta - tis.

p Et in ter - ra pax, pax ho-mi - ni - bus bo - nae vo-lun - ta - tis.

p Et in ter - ra pax, pax ho-mi - ni - bus bo - nae vo-lun - ta - tis.

Et in ter - ra pax, pax ho-mi - ni - bus bo - nae vo-lun - ta - tis.

Archi

f Lau - da - mus te, be - ne - di - ci-mus te,

f Lau - da - mus te, be - ne - di - ci-mus te, te, lau -

f Lau - da - mus te, be - ne - di - ci-mus te mus te, lau -

f Lau - da - mus te, be - ne - di - da - mus te, lau -

Tutti

pp da - mus te, a' - o - ra - mus te, ad - o - ra - mus, be - ne -

pp da - mus te ad - o - ra - mus te, ad - o - ra - mus te,

pp da - ad - o - ra - mus te mus te,

pp ad - o - ra -

Archi

pp



58

ff te, glo-ri - fi - ca - mus te, *p* ad - o - ra - - - mus te.

ff te, glo-ri - fi - ca - mus te, *p* ad - o - ra - - - mus te.

ff te, glo-ri - fi - ca - mus te, *p* ad - o - ra - - - mus te.

ff te, glo-ri - fi - ca - mus te, *p* ad - o - ra - - - mus te.

64

p Gra - ti - as a

p Gra - ti - mus bi

p Gra ti - bi

p gi - mus ti - bi

Ob, Trb *p* Arc

71

pro - - pter m. - - am.

pro - - am.

pro - - am.

ri - am tu - - am, gra - ti - as a - gi - mus

nam glo - ri - am tu - - am gi - mus

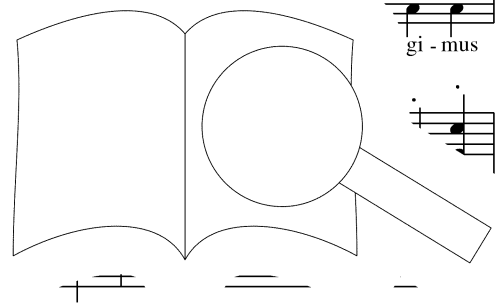

PROBEPARTITUR

Ausgabequalität gegenüber Original evtl. gemindert • Evaluation Copy - Quality may be reduced • Carus-Verlag

Do - mi - ne De - us,
 Do - mi - ne De - us,
 ti - bi pro - pter ma - gnam glo - ri - am tu - - am,
 ti - bi pro - pter ma - gnam glo - ri - am tu - - am,

Clf, Fag, Archi
 Ob, Cor

Rex coe - le - stis, gra - ti - as a - gi - mus ti - - bi,
 Rex coe - le - stis, gra - ti - as a - gi - mus ti - - bi,
 gra - ti - as a - gi - mus ti - - bi,
 gra - ti - as a - gi - mus ti - - us Pa - ter o -

Archi
 Vc

mus ti - - bi. Do -
 as a - gi - mus ti - - bi. Do -
 mni - gra - ti - as a - gi - mus ti - - k:
 gra - ti - as a - gi - mus ti -

97

mi - ne Je - su Chri - ste, gra - ti - as a - gi - mus ti - - -

mi - ne Je - su Chri - ste, gra - ti - as a - gi - mus ti - - -

gra - ti - as a - gi - mus ti - - -

gra - ti - as a - gi - mus ti - - -

102

bi,

bi,

bi. Fi - - - li - - - ni - te,

bi. Fi - - - li - - - ge - ni - te,

107

gra - ti - as a - gi - bi.

gra - ti - as - bi.

gra - bi.

as ti - - - bi.

PROBEPARTITUR
 Ausgabequalität gegenüber Original evtl. gemindert • Evaluation Copy - Quality may be reduced • Carus-Verlag

Musical score for measures 111-115. It features four vocal staves (Soprano, Alto, Tenor, Bass) and a piano accompaniment. The piano part includes a triplet of eighth notes with a 'cresc.' marking.

Musical score for measures 116-121. It features four vocal staves with lyrics and a piano accompaniment. The lyrics are "Glo - ri - a in ex - cel - sis De - o, glo - ri - a in ex - cel - sis De - o, el - sis, ex - cel - sis,". The piano part includes a "VI II" marking.

Musical score for measures 122-126. It features four vocal staves with lyrics and a piano accompaniment. The lyrics are "glo - ri - a in ex - cel - sis, glo - ri - a in ex - cel - sis, glo - ri - a in ex - cel - sis, glo - ri - a in ex - cel - sis, in ex - cel - sis, glo - ri - a in ex - cel - sis, s,". The piano part includes a "Va." marking.

Vc, Cb

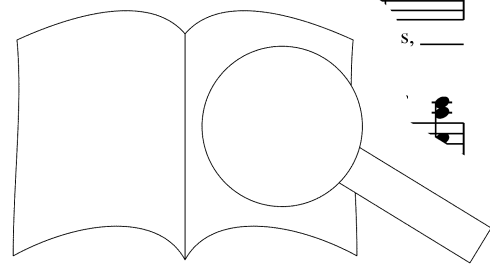

PROBENPARTITUR
 Ausgabequalität gegenüber Original evtl. gemindert • Evaluation Copy - Quality may be reduced • Carus-Verlag

in ex - cel - sis De - - o. Lau - da - mus *cresc.*
 in ex - cel - sis De - - o. Lau - da - mus *cresc.*
 in ex - cel - sis De - - o. Lau - da - mus *cresc.*
 in ex - cel - sis De - - o. Lau - da - mus *cresc.*

Tutti

te, be - ne - di - ci - mus te, glo - ri - fi - ca - - mus te, ad - o
 te, be - ne - di - ci - mus te, glo - ri - fi - ca - - mus te, us, be - - cimus
 te, be - ne - di - ci - mus te, glo - ri - fi - ca - - mus te, - ne - di - cimus
 te, be - ne - di - ci - mus te, glo - ri - fi - ca - - r ra - mus, be - ne - di - cimus

te, glo - ri - fi - ca - mus, lau - da - mus te.
 te, glo - ri - fi - ca - mus, lau - da - mus te.
 te, glo - ri - fi - ca - mus, lau - da - mus te.
 te, glo - ri - fi - ca - mus, lau - da - mus te.

PROBENPARTITUR
 Ausgabqualität gegenüber Original evtl. gemindert • Evaluation Copy - Quality may be reduced • Carus-Verlag

145 **Andante con moto**

Fag, Trb, Archi

150

ff
Do - mi - ne De - us,
ff
Do - mi - ne De - us,
ff
is De - i,

155

p
pec-ca - ta mun - di ca - ta
p
- lis pec-ca - ta
pp
ta
decresc.

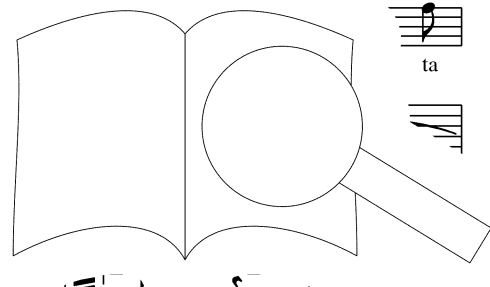

PROBEPARTITUR
Ausgabequalität gegenüber Original evtl. gemindert • Evaluation Copy - Quality may be reduced • Carus-Verlag

160

pp

Mi - se - re - re, mi - se - re - re no - bis, mi - se -

pp

Mi - se - re - re, mi - se - re - re no - bis, mi - se -

mun - di: mi - se - re - re, mi - se - re - re no - bis,

mun - di: mi - se - re - re, mi - se - re - re no - bis, mi - se -

Legni

pp

167

re - re no - bis.

re - re no - bis.

mi - se - re - re no - bis.

re - re no - bis.

Archi

se - us,

172

A

qui tol - lis pec - ca - ta

qui te - ca - ta

decresc.

p

decresc.

p

ff

bd.

simile

pp Mi - se - re - re, mi - se - re - re

pp mun - di, pec - ca - ta mun - di: mi - se - re - re, mi - se - re - re

pp mun - di, pec - ca - ta mun - di: mi - se - re - re, mi - se - re - re

pp Mi - se - re - re, mi - se - re - re

no - bis, mi - se - re - re no - bis.

no - bis, mi - se - re - re no - bis.

no - bis, mi - se - re - re no - bis.

no - bis, mi - se - re - re no - bis.

Clf, Fag

pp

b.

+Ob, Clf, Trb

Fi - li - us

Pa - tris,

i, qui tol - lis

gnus De - i,

decresc.

decresc.

simile

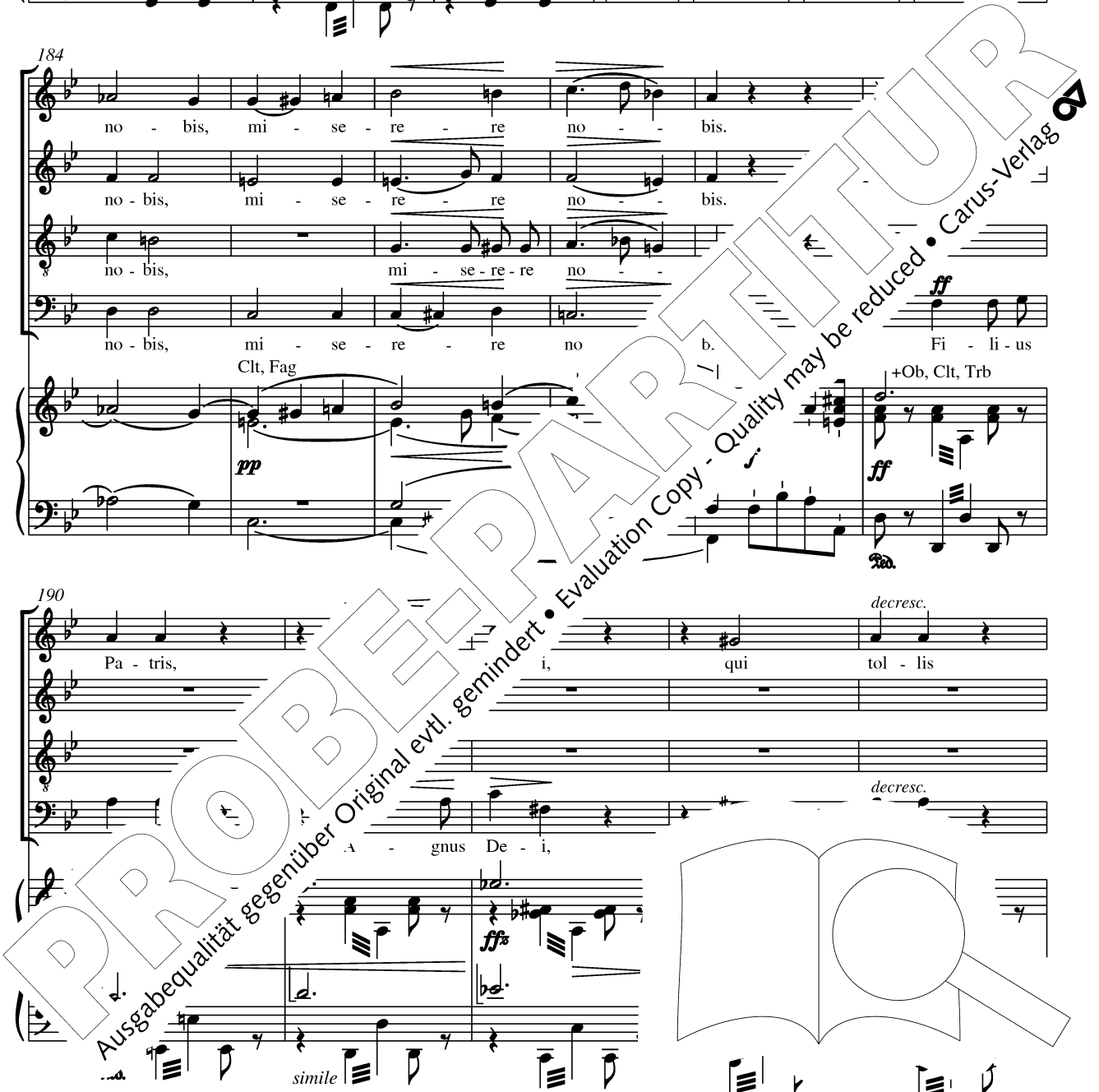

195

p pec - ca - ta mun - di, *pp* pec - ca - ta mun - di: mi - se -
 mi - se -
 mi - se -
p pec - ca - ta mun - di, *pp* pec - ca - ta mun - di: mi - se -
 mi - se -

201

re - re, mi - se - re - re no - bis, mi - se - re - re no -
 re - re, mi - se - re - re no - bis, mi - se - re - re
 re - re, mi - se - re - re no - bis, mi -
 re - re, mi - se - re - re no - bis, mi - se - re - re no -
 bis.

Clf, Fag *m* Archi

208

- us, A - gnus De - i,
 Je De - us, A - gnus De - i,
 A - gnus De - i, Fi - li - us
 li - us

simile

Fi - li - us Pa - tris, A - gnus De - i, qui tol - lis pec -

Fi - li - us Pa - tris, A - gnus De - i, qui tol - lis pec -

Pa - tris, A - gnus De - i, qui tol - lis pec - ca - ta,

Pa - tris, A - gnus De - i, qui tol - lis pec - ca - ta,

ca - ta, pec - ca - ta mun - di: mi - se -

ca - ta, pec - ca - ta mun - di: mi

pec - ca - ta mun - di: mi - se - re - re,

pec - ca - ta mun - di: mi - se - re no

bis.

decrsc.

PROBEBE PARTITUR
 Ausgabqualität gegenüber Original evtl. gemindert • Evaluation Copy - Quality may be reduced • Carus-Verlag

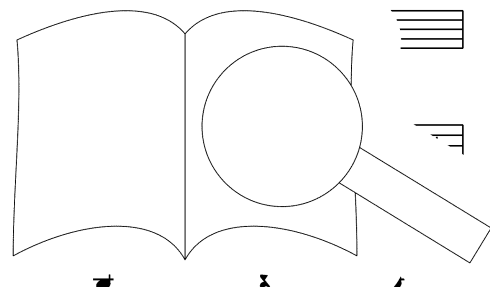

Tempo I

Quo - ni - am tu so - lus San - ctus, quo -
 Quo - ni - am tu so - lus San - ctus, quo -
 Quo - ni - am tu so - lus San - ctus, quo -
 Quo - ni - am tu so - lus San - ctus, quo -

Archi VI Tutti
 Timp

- ni - am tu so - lus San - ctus, quo - ni - am tu so
 - ni - am tu so - lus San - ctus, quo - ni - am tu so - lus Al - tis - si -
 - ni - am tu so - lus San - ctus, tu
 - ni - am tu so - lus San - ctus, quo - ni - am tu so - lus Al -

VI II Va

quo - ni - am tu so - lus Do - mi -
 so - lus, - mi - nus, tu so - lus Do - mi -
 so - lus Do - mi - nus, tu so - lus Do - mi -
 so - lus Do - mi - nus, tu so - lus Do - mi -

so - lus Do - mi - nus, tu so - lus Do - mi -

PROBE PARTITUR
 Ausgabequalität gegenüber Original evtl. gemindert • Evaluation Copy - Quality may be reduced • Carus-Verlag

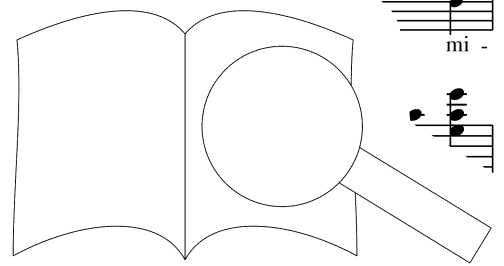

246

nus, tu so - lus, tu San - ctus, Al - tis - si -
nus, tu so - lus, tu San - ctus, Al - tis - si -
nus, tu so - lus, tu San - ctus, Al - tis - si -
nus, tu so - lus, tu San - ctus, Al - tis - si -

cresc. *ff.* *cresc.* *ff.* *cresc.* *ff.* *cresc.* *ff.*

250

mus, quo-ni-am tu so-lus Al-tis-si-mus,
mus, quo-ni-am tu so-lus Al-tis-si-mus,
mus, quo-ni-am tu so-lus Al-tis-si-mus,
mus, quo-ni-am tu so-lus Al-tis-si-mus,
mus, quo-ni-am tu so-lus Al-tis-si-mus,
mus, quo-ni-am tu

p

257

so - lus Do
so - lus
so -

mi - nus. Cum San - c
a

Ctr, Cor
Bassi, Fag, Trb

PROBE PARTITUR

Ausgabequalität gegenüber Original evtl. gemindert • Evaluation Copy - Quality may be reduced • Carus-Verlag

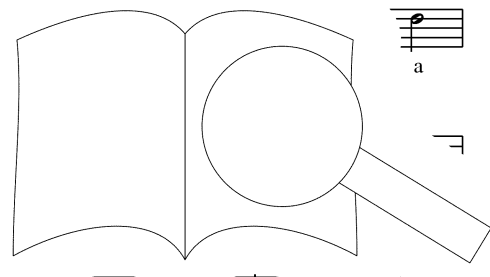

Cum San-cto Spi-ri-tu, in
De-i Pa-tris A-men, cum San-cto Spi-ri-tu, in glo-ri-a

ctr, Cor
Va, Fag, Trb

glo-ri-a De-i Pa-tris A-
De-i Pa-tris A-men, a-

Cum San-cto Spi-ri-tu, in glo-ri-a De-i Pa-tris A-
men, glo-ri-a De-i Pa-tris A-men,
Spi-ri-tu, cum San-cto Spi-ri-tu, in glo-ri-a

PROBEPARTITUR

Ausgabequalität gegenüber Original evtl. gemindert • Evaluation Copy - Quality may be reduced • Carus-Verlag

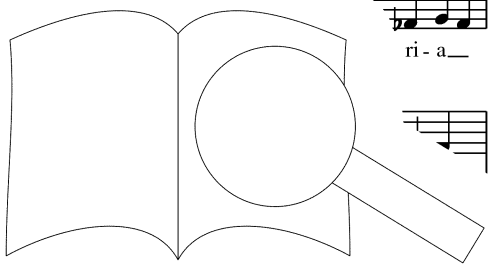

290

Cum San-cto Spi-ri-tu, in glo-ri-a

A - - - - - men, cum San-cto Spi-ri-tu, in glo-ri-a De-i Pa-tris.

a - - - - - men, cum San-cto Spi-ri-tu, cum San-cto Spi-ri-

De-i Pa-tris. A - - - - - men,

VI I, Ob

Va, Vc, Fag II

298

De-i Pa-tris. A - - - - -

A - - - - - men, a - - - - -

tu, in glo-ri-a De-i Pa-tris. A - - - - - cum San-cto

- - - - - cum San-cto

Tutti

Bassi

306

tu, in glo-ri-a De-i Pa-tris,

- - - - - men, cum San-cto

- - - - - glo-ri-a De-i Pa-tris

n glo-ri-a De-

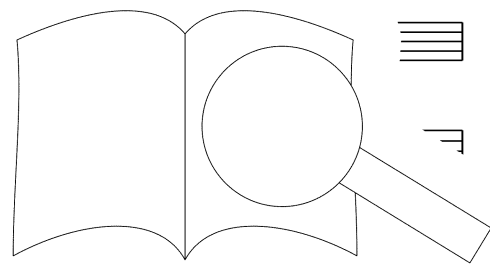
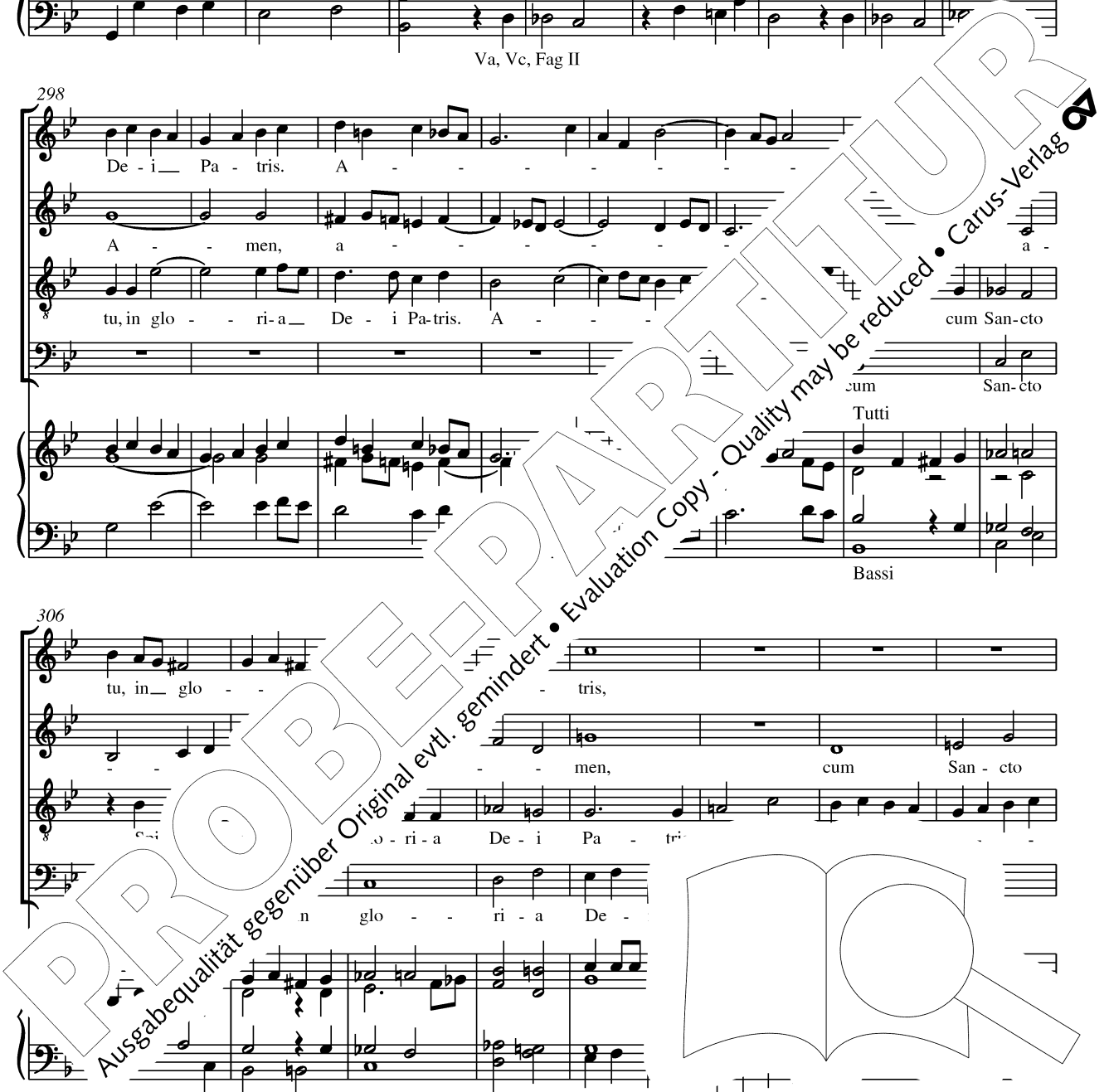

cum San - cto Spi - ri - tu, in glo - - - ri - a De - - - i
 Spi - ri - tu, in glo - ri - a, in glo - - - ri - a De - - - i
 men, cum San - cto Spi - ri - tu, in glo - - - ri - a
 cum San - cto Spi - ri - tu, in glo - - - ri - a

Pa - - tris. A - - men, a
 Pa - - tris. A - - men, san - cto
 De - - i Pa - - tris. A cum San - cto
 De - - i Pa - - tris. nen,
 Archi
 Va, Vc

tu, in glo - - - tris.
 Spi - ri - a De - i Pa - tris. A - -
 San - cto Spi - ri - tu, i -
 cum
 in
 Bassi

PROBEPARTITUR
 Original evtl. gemindert • Evaluation Copy - Quality may be reduced • Carus-Verlag

A - men, a - men, a - - - men, a - men, a - men, a - men, a - men,
 men, a - - - - - men, a - men, a - men, a - men, a - men,
 Pa - tris, _____ in glo - ri - a De - i Pa - tris. A - men,
 glo - - ri - a De - i Pa - tris. A - - men, a - - men,

a - men, a - men, a - men, a - men, a - men, a - men,
 a - men, a - men, a - men, a - men, a - men, a - men,
 a - men, a - men, a - men, a - men, a - men, a - men,
 a - men, a - men, a - men, a - men, a - men, a - men,

men,
 men,
 mer cum San - cto Spi - ri a
 pi - ri - tu, in glo - ri - a

...o, Fag

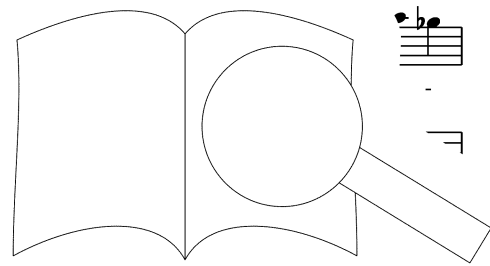

PROBEPARTITUR
 Ausgabequalität gegenüber Original evtl. gemindert • Evaluation Copy - Quality may be reduced • Carus-Verlag

cum San - cto Spi - ri -
 cum San - cto Spi - ri - tu, in glo - ri - a
 De - i Pa - tris, cum San - cto Spi - ri - tu, in glo - ri - a De - i Pa - tris.
 - - - - men, cum San - cto Spi - ri - tu, in glo - ri - a
 Ob, Clt

tu, in glo - ri - a De - i Pa - tris
 De - i Pa - tris. A - men, a - men,
 A - men, a - men,
 De - i Pa - tris. A - men, a - men,
 a - men,
 cto - Spi - ri -
 a - men,

a - men, a - men, a - men, a - men, a -
 a - men, a - men, a - men, a - men, a -
 ... - i Pa - tris. A - men, a - men,
 a - men, a - men, a - n
 men,
 men,

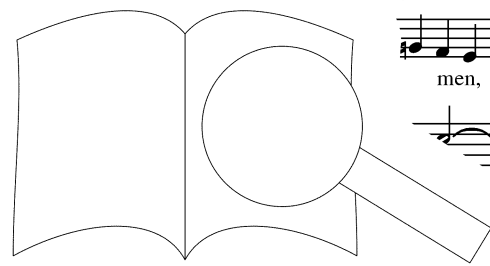

PROBENPARTITUR
 Ausgabqualität gegenüber Original evtl. gemindert • Evaluation Copy - Quality may be reduced • Carus-Verlag

387

men, cum

men,

cum San-cto Spi-ri-tu, in glo-ri-a De-i Pa-tris.

a-men, cum San-cto Spi-ri-tu, in glo-ri-a De-i

+Archi m.d.

397

San-cto Spi-ri-tu, in glo-ri-a De-

cum San-cto Spi-ri-tu, in glo

Pa-tris. A-

405

tris. A-

men, a-men, a-men, a-

Pa-tris. A-

men, a-men, a-men, a-

men, a-men, a-men, a-

men,

men,

PROBEPARTITUR

Ausgabequalität gegenüber Original evtl. gemindert • Evaluation Copy - Quality may be reduced • Carus-Verlag

a - - - men, a - - - men, a - - - men, a -

- - - men, a - - - men, a - - - men, a -

a - - - men, a - - - - - men, a - men, a -

a - - - men, a - - - - - men, a - men, a -

men,

men,

men,

men,

Legni, Trb

p

Timp

in glo - ri - a De - i Pa - tris. A - -

San - cto Spi - ri - tu, in glo - ri - a De - i Pa - -

cum San - cto Spi - ri - tu. Pa - tris. A -

a San - cto Spi - ri - tu, in - tris.

Archi

PROBEPARTITUR

Ausgabequalität gegenüber Original evtl. gemindert • Evaluation Copy - Quality may be reduced • Carus-Verlag

men, a - men, a - - men, a - men, a - -
 tris. A - men, a - - men, a - men, a - -
 men, cum San - cto Spi - ri - tu, in glo - ri - a De - - i, in
 A - - - men, a - - - - men, a - - - - men, a - - - - men,

+Legni, Ottoni **Tutti**
f *ff* *ff*

men, a - men, a - men, a - - r
 men, a - men, a - men, a - -
 glo - ri - a De - i Pa - tris. A - men, a -
 a - - - men, a - men, a - men,

f *ff* *ff* Ctr, Cor

a - - - - - men.
 a - - - - - men.
 a - - - - -

f *ff* *ff*

PROBEPARTITUR
 Ausgabequalität gegenüber Original evtl. gemindert • Evaluation Copy - Quality may be reduced • Carus-Verlag

Credo

Moderato

Soprano

Alto

Tenore

Basso

2 Oboi
2 Clarinetti
2 Fagotti
2 Corni
2 Clarini
3 Tromboni
Timpani
Archi
Bassi

p

Cre - - - do in u - num De -

pp

Timp

pp

Vc, Cb pizz.

8

um,

um,

um,

um,

Cor

Fag, T

Archi pizz.

fa - - cto - -

cto - -

15

rem

rae, vi - si - bi - li - um

rae, vi - si - bi - li - um

ter - - - rae, - li - um

li et ter - - - rae, li - um

PROBEPARTITUR

Ausgabequalität gegenüber Original evtl. gemindert • Evaluation Copy - Quality may be reduced • Carus-Verlag

o - mni - um, et in - - vi - si - bi - li - um, et in - vi - si -

o - mni - um, et in - - vi - si - bi - li - um, et in - vi - si -

o - mni - um, et in - - vi - si - bi - li - um, et in - vi - si -

o - mni - um, et in - - vi - si - bi - li - um, et in - vi - si -

pp

bi - - li - um.

bi - - li - - um.

bi - - li - - um.

bi - - li - - um.

Timp

Do - mi - num Je - sum Chri - -

Do - mi - num Je - sum Chri - -

Do - mi - num Je -

+Ob

+Trb

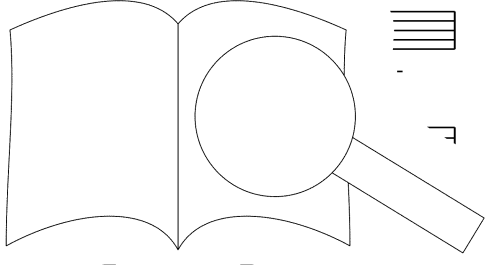

PROBEPARTITUR

Ausgabequalität gegenüber Original evtl. gemindert • Evaluation Copy - Quality may be reduced • Carus-Verlag

47

stum, cre - do in Fi - li - um De - i u - ni - ge - ni -

stum, cre - do in Fi - li - um De - i u - ni - ge - ni -

stum, cre - do in Fi - li - um De - i u - ni - ge - ni -

stum, cre - do in Fi - li - um De - i u - ni - ge - ni -

Clf, Fag, Cor

Archi pizz.

Timp

55

tum. Et ex P te

tum. Et ex

tum. Et ex Pa - tre mni - a

Clf, Fag, Cor

Trb

Timp

63

sae - - cu am de De - o, lu - men de

o - mni - a De - um de De - o, lu - men de

Pa De - um de De - o, lu - men de

la. De - um de De - men de

Clf, Fag

Ob

PROBENPARTITUR

Ausgabequalität gegenüber Original evtl. gemindert • Evaluation Copy - Quality may be reduced • Carus-Verlag

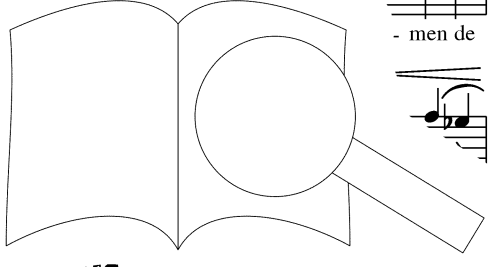

lu - mi - ne, De - um ve - rum de De - o
 lu - mi - ne, De - um ve - rum de De - o
 lu - mi - ne, De - um ve - rum de De - o
 lu - mi - ne, De - um ve - rum de De - o

ve - ro. Per quem o - r
 ve - ro. o - mni - a
 ve - ro. Per quem
 ve - ro. Per quem o sunt, per quem

fa per quem
 fa per quem o - mni - a
 sunt, per quem
 cta sunt, per quem o - mni - a fa

PROBEPARTITUR
 Ausgabegualität gegenüber Original evtl. gemindert • Evaluation Copy - Quality may be reduced • Carus-Verlag

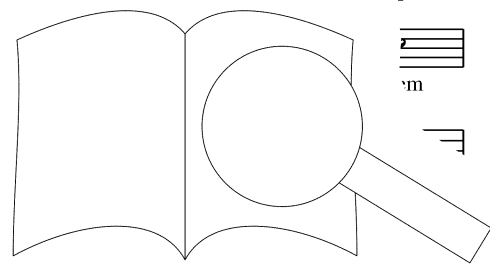

o - mni-a fa - cta sunt.
 fa - - - cta sunt.
 - - - - cta sunt.
 fa - - - cta sunt.

Arch.
decrsc.
p
f
 Timp

Qui pro - pter nos ho - mi - nes,
 Qui pro - pter nos ho - mi - nes,
 Qui pro - pter nos ho - mi - nes,
 Qui pro - pter nos ho - r

et pro - pter

p
pizz.
 Clt,

no - stram sa - lu
 no - stram sa
 no

de - scen - dit, de - scen - dit de
 de - scen - dit, de - scen - dit de
 de - scen - dit de

tem de lit de

Clt, Fag

coe - - - lis.

coe - - - lis.

coe - - - lis.

coe - - - lis.

Ob, Fag, Trb

pp

pp Timp

Et incarnatus est
Andante

Archi

Vc *p*

pp

Ten. I solo

Ten. II

Et in de



Spi - ri - tu San - cto ex - Ma - ri - a, Mari - a

Ob, Clt
Cor, Fag

pp

Vir - gi - ne: Et ho - mo fa -

+Clt

Ten. I
as est, et in - car - na - tus est de Spi - ri - tu
in - car - na - tus est ri - tu

Ob, Clt

San - cto, de Spi - ri - tu San - cto ex - Ma - ri - a Vir - gi - ne:
 San - cto ex - Ma - ri - a, Ma - ri - a Vir - gi - ne: Et

Cor, Fag Ob, Clt

Sopr. solo
 Et
 Et ho - mo fa - ctus est.
 ho - mo fa - ctus est. in - car - na - tus

na - tus est - - - ri - tu San - cto ex - Ma -
 Et de Spi - ri - tu San - cto ex Ma - ri - a
 - car - na - tus est de

Ob



ri - - a, Ma - ri - a Vir - gi - ne: Et ho - mo fa - - ctus

Vir - gi - ne, Ma - ri - a Vir - gi - ne: Et ho - mo fa - - ctus

Spi - ri - tu San - cto ex Ma - ri - a Vir - gi - ne: Et ho - mo fa - ctus

Cor, Fag +Ob

est.

Tutti *pp*

Tutti *pp* Cru - ci - fi

Ten. I

Tutti *pp* Cru - ci

Ten. II est.

Cru -

Basso est.

Tutti *pp*

Cr - - - xus

Archi

decresc.

cresc.

et - i - sub Pon - ti - o Pi - la - to,

cresc.

et - bis: sub Pon - ti - o Pi - la - to,

cresc.

no - - bis: sub Pon - to,

pro no - - bis: sub P

+Legni, Trb

fp

PROBEPARTITUR

Ausgabequalität gegenüber Original evtl. gemindert • Evaluation Copy - Quality may be reduced • Carus-Verlag

165

ppp
cru - ci -

ppp
cru - ci -

ppp
cru - ci - fi - xus

ppp
cru - ci - fi - xus

Ob Clt +Fag

pp *decresc.* *ppp*

167

cresc.
fi - xus et - i - am pro no - bis: sub P

cresc.
fi - xus et - i - am pro no - bis: ti - Pi -

cresc.
et - i - am pro no - bis: sub Pon - ti to, sub

cresc.
et - i - am pro no - bis: sub Pon o - to, sub

+Ctr *utti*

cresc. *f* *ff* 3 3

169

la - to, am, cru - ci - fi - xus,

la - to, cru - ci - fi - xus,

Pon - to, cru - ci - fi - xus,

la - to, cru - ci - fi

ff 3 3 *ff*

PROBEPARTITUR
Ausgabequalität gegenüber Original evtl. gemindert • Evaluation Copy - Quality may be reduced • Carus-Verlag

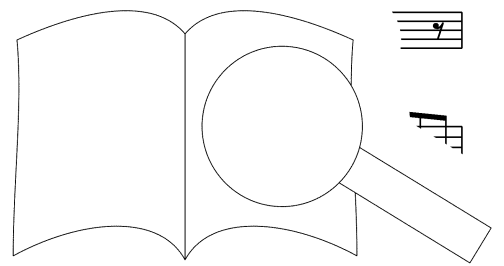

171

p

pas - - sus et se - - pul - - - tus

pas - - sus et se - - pul - - - tus

pas - - sus et se - - pul - - - tus

pas - - sus et se - - pul - - - tus

Ob, Clt

pp

173

est.

est.

est.

est.

175

Solo

Et

est de Spi - - - ri - tu

Ten. II solo

Et

+Cor, Fag

ipi-ri-tu

San - cto ex Ma - ri - - a, Ma - ri - a Vir - gi - ne: Et

Ten. I solo
Ex Ma - ri - a Vir - - gi - ne, Ma - ri - a Vir - gi - ne: Et

San - cto, de Spi - ri - tu San - cto ex Ma - ri - a Vir - gi - ne:

Ob, Clt Cor, Fag +Ob

ho - mo fa - - ctus est.

ho - mo fa - - ctus est.

Etho - mo fa - ctus est.

xus
fi - xus

Tutti *pp*
Tutti *pp*
Tutti *pp*
Basso Tutti *f*
Archi *de*

cresc. et - i - am
cresc. et - i - am
cresc. et - i - am
et a.

Pon - ti - o Pi - la - - to,
: sub Pon - ti - o Pi - la - - to,
bis: sub Pon - ti - to,
no - bis: sub Pon -

Ob, Fag, Trb Clt
fp *cresc.*

ppp

cru - ci -

ppp

cru - ci -

ppp

cru - ci - fi - xus

ppp

cru - ci - fi - xus

Ob Clt +Fag

ppp

decresc.

ppp

cresc.

fi - xus et - i - am pro no - - bis: sub Pon

cresc.

fi - xus et - i - am pro no - - bis: ti Pi -

cresc.

et - i - am pro no - bis: sub Pon - ti - to, sub

cresc.

et - i - am pro no - bis: sub Pon - to, sub

cresc.

f

ff

3 3

la - to. Pi - la - - to, cru - ci - fi - xus

la - o Pi - la - - to, cru - ci - fi - xus

Pon - to, cru-ci - fi - xus et - i - am pro - - bis,

la - - to, cru-ci - fi - bis,

ff

3 3

cresc.

PROBEPARTITUR

Ausgabequalität gegenüber Original evtl. gemindert • Evaluation Copy - Quality may be reduced • Carus-Verlag

192

et - i - am pro no - bis, cru - ci - fi - - - - xus,
et - i - am pro no - bis, cru - ci - fi - - - - xus,
et - i - am pro no - bis, cru - ci - fi - - - - xus,
et - i - am pro no - bis, cru - ci - fi - - - - xus,

fff
fff
fff
fff
ff *fff* *cresc.*

194

pas - sus et se - pul - - - - tus
pas - sus et se - pul - - - - tus
pas - sus et se - pul - - - - tus
pas - sus et se - pul - - - - tus

pp
pp
pp
pp
p *cresc.*

196

est.
est.
est.
est.

ff *p*

PROBE PARTITUR

Ausgabequalität gegenüber Original evtl. gemindert • Evaluation Copy - Quality may be reduced • Carus-Verlag

Et resurrexit

Tempo I

198

Legni, Ottoni

Timp

pp *p cresc.* *f*

Et re-sur-

206

f

Et re-sur-re-xit ter-ti-a di-e, se-cun-dum Scri-ptu-

f Et re-sur-re-

f Et re-sur-re-xit, se-c-

re-xit ter-ti-a di-e, se-cun-dum Et a-scen-dit in

+Archi

215

f

Et a-sce- et ad de-xte-ram Pa-tris. Et i-te-

-scen-dit in coe-lum. Et i-te-

Et a-scen-dit in co- Et i-te-

et ad de-xte-ram Pa-

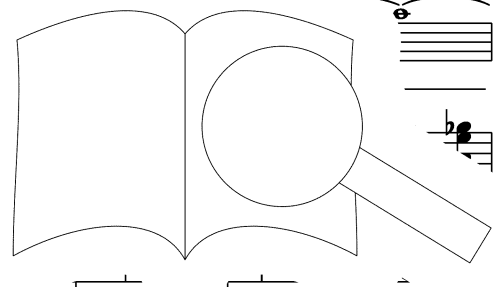

PROBEPARTITUR
 Ausgabegualität gegenüber Original evtl. gemindert • Evaluation Copy - Quality may be reduced • Carus-Verlag

rum ven - tu - rus est, ven - tu - rus est cum glo - ri - a,
 rum ven - tu - rus est, ven - tu - rus est cum glo - ri - a,
 rum ven - tu - rus est, ven - tu - rus est cum glo - ri - a,
 ven - tu - rus est, ven - tu - rus est cum glo - ri - a, ju - di -

ff

ju - di - ca - re vi - vos et mor - tu - os: cu
 ju - di - ca - re vi - vos et mor - tu - os:
 ju - di - ca - re vi - vos et mor - tu - os: re - -
 ca - re vi - vos et mor - tu - os: jus re - -

ff *p*

gni non e - nis, non e - rit fi - -
 gni non. fi - nis, non e - rit fi - -
 gni fi - nis, non
 rit fi - nis, n

nis. *p* Cre -

nis. *p* Cre -

nis. *p* Cre -

nis. *p* Cre -

+Clt +Fag, Cor

pp

Timp

do in Spi - ri - tum San - ctum, Do - mi - num,

do in Spi - ri - tum San - ctum, Do - - mi - - num

do in Spi - ri - tum San - ctum, Do - - mi -

do in Spi - ri - tum San - ctum, Do - - m:

Ob Bassi

p

Timp

Fag, Trb

pp

et *tem:* qui ex Pa - tre Fi - li - o - que pro - ce - dit.

can - tem: qui ex Pa - tre Fi - li - o - que pro - ce - dit.

- fi - can - tem: qui ex Pa - tre Fi - li - o - que pro - ce - dit.

vi - vi - fi - can - tem: qui - dit.

Archi Ob

pp

Clc

PROBEPARTITUR

Ausgabequalität gegenüber Original evtl. gemindert • Evaluation Copy - Quality may be reduced • Carus-Verlag

Qui cum Pa - tre et Fi - li - o si - mul ad - o - ra - -

Qui cum Pa - tre et Fi - li - o

Qui con - glo - ri - fi -

Qui cum Pa - tre et Fi - li - o si - mul ad - o - ra - tur, et con - glo - ri - fi - ca - -

Archi, Ob

Bassi

- - tur: qui lo - cu - tus est p

ad - o - ra - tur: qui - phe -

ca - - tur: - cu - tus est

tur: qui lo - cu - tus est per Pro - phe -

- - tas. u - num ba - ptis - - ma in re -

- - ta. te - or u - num ba - ptis - - ma in re -

per Pro - fi - te - or u - num ba - ptis - - ma in re -

Con - fi - te - or u - num l re -

Ob

Cor, Fag

Vc, Cb pizz.

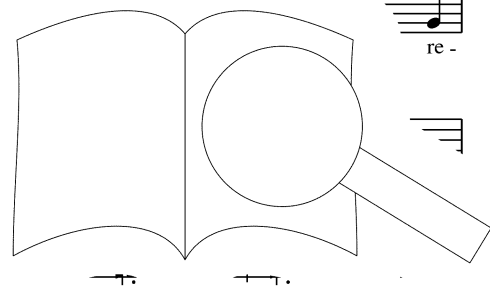

PROBE PARTITUR

Ausgabequalität gegenüber Original evtl. gemindert • Evaluation Copy - Quality may be reduced • Carus-Verlag

300

mis - si - o - - nem pec - ca - to - rum, mor - tu - o - - - rum.

mis - si - o - - nem pec - ca - to - rum, mor - tu - o - - - rum.

mis - si - o - - nem pec - ca - to - rum, mor - tu - o - - - rum.

mis - si - o - - nem pec - ca - to - rum, mor - tu - o - - - rum.

308

Et vi - tam ven -

Archi

Tutti con Coro

316

li, ven - tu - ri - sae - ct

Et sae - cu - ven -

PROBEPARTITUR

Ausgabequalität gegenüber Original evtl. gemindert • Evaluation Copy - Quality may be reduced • Carus-Verlag

324

f

Et vi - tam ven - tu - ri sae - cu - li, ven -
 li, ven - tu - ri sae - cu - li. A - - - men, a - - -
 tu - ri sae - cu - li. A - - - men, a - - - men, a - - -

332

f

Et vi - tam ven - tu - ri sae - cu - li, ven -
 tu - ri sae - cu - li. A - - - men, ven - tu -
 men, a - - - men, et vi - tam ven - tu - ri
 - - - men,

340

A - - - men, a
 - - - men, a - - - men, a -
 - - - men, a - - - men, a -
 - tu - ri sae - cu - li,

PROBEPARTITUR
 Ausgabequalität gegenüber Original evtl. gemindert • Evaluation Copy - Quality may be reduced • Carus-Verlag

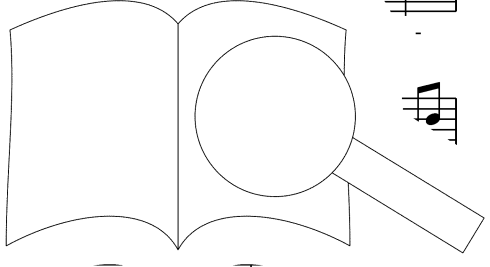

348

men, et vi-tam ven-tu-ri sae-cu-li, ven-tu-ri
 men, a-men, a-men, a-men, a-
 men, a-men, et vi-tam ven-tu-ri sae-cu-li.

356

sae-cu-li. A-men, a-
 men, a-men, tam-ri
 A-men, et ven-sae-cu-li. A-men,

364

men, a-men,
 sae-cu-li. a-men, a-men,
 en, a-men,

PROBEPARTITUR
 Ausgabequalität gegenüber Original evtl. gemindert • Evaluation Copy - Quality may be reduced • Carus-Verlag

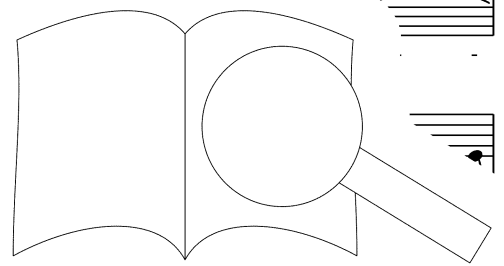

a - - men, a - - men, a - -
 men, a - - men, a - - men, a - - men,
 a - - men, a - - men, a - - men, a - - men,
 men, a - - men, a - -

- - - men, a - men, a - men, a -
 a - - - men, a - - - men, a -
 a - - - men, a - - - men, a - men,
 men, a - - men, a - -

cu -

Ausgabequalität gegenüber Original evtl. gemindert • Evaluation Copy - Quality may be reduced • Carus-Verlag

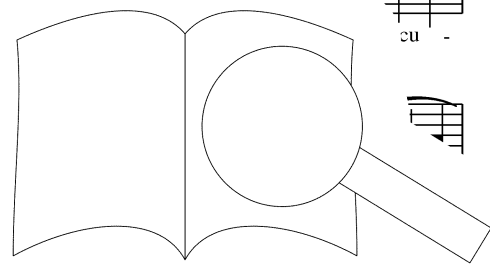

a - - men, a - - men,
 - - - men, a - - - men, a - - - men, a -
 - - - men,
 li, ven - tu - ri - sae - cu - li. A - - - men, a - - - men, a -

Tutti

a - - men, a - men, a - - men,
 - - - men, a - - - men, a - - -
 a - - men, a - - men, a - men, a -
 - - - men, a - - - men, a - - - men,

a - - me - - - men, a - - men, a - -
 a - - - men, a - - men, a - -
 - - - men, a - men, a - -
 a - - men, a - - men, a - -
 tam ven -

PROBENPARTITUR
 Ausgabequalität gegenüber Original evtl. gemindert • Evaluation Copy - Quality may be reduced • Carus-Verlag

men,
 men, et vi - tam ven - tu - ri sae - cu -
 men, a - men, a - men, a -
 tu - ri sae - cu - li, ven - tu - ri sae - cu - li. A - men, a -

Tutti

et vi - tam ven - tu - ri sae - cu -
 li, ven - tu - ri sae - cu - li.
 men, a -
 men, a - men, a - men,

sae - cu - li. a - men,
 men, a - men, a - men, et vi - tam ven -
 ri sae - cu - li. A - men a - men, et
 men, a

PROBE PARTITUR
 Ausgabequalität gegenüber Original evtl. gemindert • Evaluation Copy - Quality may be reduced • Carus-Verlag

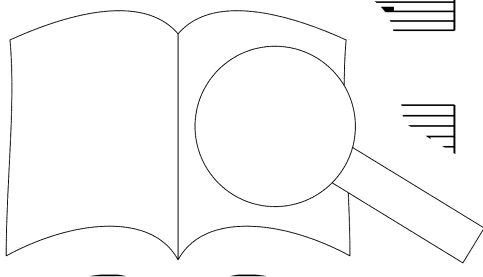

men, a - - - men, a - - -

a - - - men, a - - - men, a - - -

a - - - men, a - - - men, a - - -

a - - - men, et vi - tam ven - tu - ri sae - cu - li. A - - -

men, _____

men, _____

men, _____ et vi - tam ven - tu - ri _____

men, _____ et vi - tam ven - tu - ri sae _____ i, _____ ri sae - cu -

Legni, Ottoni

Timp

vi - tam ven - tu _____ ven - tu - ri sae - cu - li. A - - - men, _____

vi - tam ven - tu _____ li, ven - tu - ri sae - cu - li. A - - - men,

men. _____ ri sae - cu - li. A - - -

et vi - tam ven - tu _____

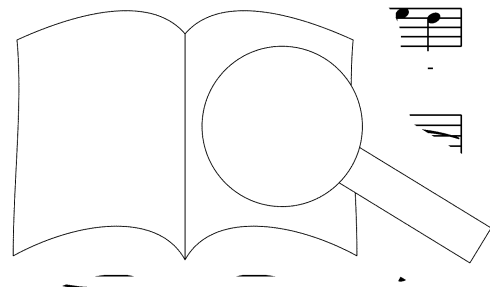

491

a - - - men,
 a - - - men,
 men, a - - - men,
 - - - men, a - - - men,

Archi

p

Cor

499

et vi - tam ven - tu - ri sae - cu -
 et vi - tam ven - tu - ri sae
 et vi - tam
 et vi - - - tam ven -

p

p

p

p

ri -
 A -
 A - -

507

sae - cu - li,
 sae - cu
 et vi - tam ven - tu - ri sae - cu - li. A - -
 et vi - tam ven - tu - r,

ri sae - cu - li, ven - tu - ri sae - cu - li.
 tu - ri sae - cu - li, ven - tu - ri sae - cu - li.
 et vi - tam ven - tu - ri sae - cu - li. A - -
 cu - li.

cresc.

cresc.

cresc.

cresc.

PROBEPARTITUR

Ausgabequalität gegenüber Original evtl. gemindert • Evaluation Copy - Quality may be reduced • Carus-Verlag

515

A - - men, et vi - tam ven - tu - ri sae - cu - li, et vi - tam ven - tu - ri
 A - - men, et vi - tam ven - tu - ri sae - cu - li, et vi - tam ven - tu - ri
 - - men, et vi - tam ven - tu - ri sae - cu - li, et vi - tam ven -
 A - men, a

Tutti

cresc. Cor

523

sae - - - cu - li. A - - - men,
 sae - - - cu - li. A - - - men,
 tu - ri sae - - - cu - li. A - - - men,

musical accompaniment for the second system

531

- - men, - - - men.
 - - men - - - men.
 - - - men.

musical accompaniment for the third system

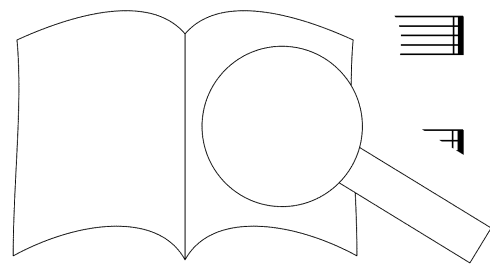

PROBEPARTITUR
 Ausgabequalität gegenüber Original evtl. gemindert • Evaluation Copy - Quality may be reduced • Carus-Verlag

Sanctus

Adagio

Soprano
Alto
Tenore
Basso

2 Oboi
2 Clarinetti
2 Fagotti
2 Corni
2 Clarini
3 Tromboni
Timpani
Archi
Bassi

Archi 6 6 simile
Fag, Cor

+Legni, Trb

Detailed description: This system contains the vocal staves for Soprano, Alto, Tenor, and Bass, and the instrumental staves for Oboes, Clarinets, Bassoons, Horns, Clarinets, Trombones, Timpani, and Strings. The vocal parts begin with the word 'Sanctus' in a long note, followed by a rest and then 'Sanctus' again. The instrumental parts feature a rhythmic pattern of eighth notes in the strings and woodwinds, with dynamics ranging from piano (p) to fortissimo (ff).

ctus, San - - - ctus
ctus, San - - - ctus
ctus, San - - - ctus
ctus, San - - - ctus

De - us
- mi - nus De - us
Do - mi - nus De - us

Tutti

Trb

Detailed description: This system continues the vocal parts and instrumental accompaniment. The vocal parts sing 'Sanctus' followed by 'Sanctus' and then 'Deus Dominus Deus Dominus Deus'. The instrumental parts continue with the rhythmic pattern, with dynamics increasing to fortissimo (ff) and then fortississimo (fff). A 'Tutti' marking is present.

8

Sa - ba - oth. Ple - ni sunt coe - li, coe - li et ter - ra
Sa - Ple - ni sunt coe - li glo - ri - a tu - a, coe - li et ter - ra
Sa - Ple - ni sunt coe - li et ter - ra

Ple - ni sunt coe - li et ter - ra

Detailed description: This system continues the vocal parts and instrumental accompaniment. The vocal parts sing 'Sabaoth. Pleni sunt coeli, coeli et terra. Pleni sunt coeli gloria tua, coeli et terra. Pleni sunt coeli et terra'. The instrumental parts continue with the rhythmic pattern, with dynamics ranging from fortissimo (ff) to fortississimo (fff).

11

ff glo-ri-a tu - a. *p* San - - ctus,

ff glo-ri-a tu - a. *p* San - - ctus,

ff glo-ri-a tu - a. *p* San - - ctus,

ff glo-ri-a tu - a. *p* San - - ctus,

Archi

Timp *ff* *p* Fag *p* Far

14

f San - ctus, *ff* San - ctus

f San - ctus, *ff* San - ctus

f San - ctus, *ff* San - ctus

f San - ctus, *ff* San - ctus

f San - ctus, *ff* San - ctus

f San - ctus, *ff* San - ctus

us De - us

mi - nus De - us

+Legni, Trb

f *p* 6 6 *fff*

Trb

17

Sa - ba-oth. Ple - ni sunt coe - li, coe - li et ter - ra

Sa - ba-oth. Ple - ni sunt coe - li, ple - ni sunt coe - li, coe - li et ter - ra

Sa - Ple - ni sunt coe - li + ter - ra

Ple - ni sunt coe - li et ter - - ra

6 6 *ff*

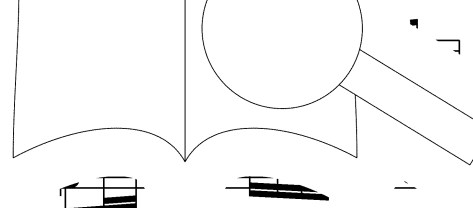

PROBEPARTITUR

Ausgabequalität gegenüber Original evtl. gemindert • Evaluation Copy - Quality may be reduced • Carus-Verlag

20

ff glo - ri - a tu - a, *fff* ple - ni sunt coe - li et ter - ra

ff glo - ri - a tu - a, *fff* ple - ni sunt coe - li et ter - ra

ff glo - ri - a tu - a, *fff* ple - ni sunt coe - li et ter - ra

ff glo - ri - a tu - a, *fff* ple - ni sunt coe - li et ter - ra

ff Timp *p* Archi *fff* Tutti Fag

23 **Allegro ma non troppo**

pp glo - ri - a tu - - - a.

pp glo - ri - a tu - - - a.

pp glo - ri - a tu - - - a. O - san - na ir

pp glo - ri - a tu - - - a. san - - - na in ex -

pp Archi *Tutti*

30 *f* O - san - - - sis - De - - - o, in ex -

O - san - - - na in ex - cel - sis - De - -

o - san - - - san

is - De - - - o -

38

cel - sis, in ex - cel - sis De - - o,
 o, in ex - cel - sis De - - o, o - san - -
 na in ex - cel - - sis, o - san - - na, o - san - - na in ex -
 san - na, o - san - - na, o - san - na in ex - cel - sis De - -

46

o - san - na, o - san - - na, o - san - -
 na in ex - cel - - sis, o - san - - na, o - san in ex -
 cel - - sis De - - o, o - san in ex -
 o, o - san - - na, o - san - - na

54

in ex - cel o - san - - na in ex -
 cel - o - san - - na, o -
 cel o - san - - na in ex -
 sis, o - san - - na in e

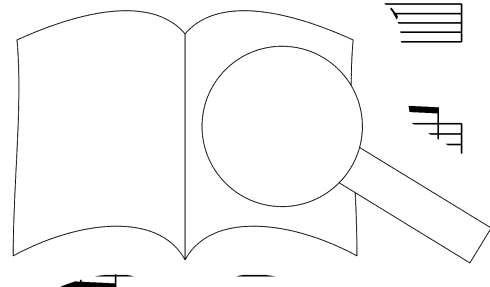

PROBEPARTITUR
 Ausgabequalität gegenüber Original evtl. gemindert • Evaluation Copy - Quality may be reduced • Carus-Verlag

62

cel - - sis, o - san - na in ex - cel - sis De - o,

san - - na in ex - cel - - sis, in ex - cel - sis De - - o,

cel - - sis, o - san - - na in ex - cel - sis De - - o, o -

o - san - - na in ex - cel - sis De - - o,

70

o - san - - - - na in ex - cel -

o - san - - - - na in ex -

san - - - - na in De - -

o - san - na sis De - -

78

o,

san - - - - na,

o - san - - - - na,

o - san - - - - na,

PROBENPARTITUR

Ausgabequalität gegenüber Original evtl. gemindert • Evaluation Copy - Quality may be reduced • Carus-Verlag

Benedictus

Andante

Soprano

Alto

Tenore

Basso

2 Oboi
2 Clarinetti
2 Fagotti
2 Corni
2 Clarini
3 Tromboni
Timpani
Archi
Bassi

Solo *p*

Be - ne - di - ctus qui

Be - ne - di - ctus qui

Be - ne - di - ctus qui

Be - ne - di - ctus qui

Archi

p

pp

7

ve - nit in no - mi - ne Do - mi - ni, be - ne - di - ctus

ve - nit in no - mi - ne Do - mi - ni, be - ne - di - ni - mi - ne

ve - nit in no - mi - ne Do - mi - ni, be - ne - nit in no - mi - ne

ve - nit in no - mi - ne Do - mi - ni, be - ve - nit in no - mi - ne

12

Do - mi - ni

Do - n.

Do -

qui ve - nit in no - mi - ne

qui ve - nit in no - mi - ne

qui ve - nit in no - mi - ne

qui ve -

at, Fag, Trb

Do - mi - ni, qui ve - nit in no - mi - ne Do - mi - ni.

Do - mi - ni, qui ve - nit in no - mi - ne Do - mi - ni.

Do - mi - ni, qui ve - nit in no - mi - ne Do - mi - ni.

Do - mi - ni, qui ve - nit in no - mi - ne Do - mi - ni.

Legni, Trb

di - ctus qui

Be - ne -

Tutti *f*

in no - mi - ne

Tur

Be -

ve -

Tutti *fz*

ne - di - ctus qui ve - nit.

ne Do - mi - ni, in no - mi - ne Do - mi - ni.

qui ve - nit in no - mi - ne,

decrsc. Solo *p*

Be - ne -

decrsc. *p*

decrsc. *p*

PROBEPARTITUR

Ausgabequalität gegenüber Original evtl. gemindert • Evaluation Copy - Quality may be reduced • Carus-Verlag

Solo

Be - ne - di - ctus qui ve - nit, be - ne - di - ctus qui ve - nit in no -
 di - ctus qui ve - nit in no - mi - ne Do - mi - ni, qui ve - nit in no -
 Be - ne - di - ctus qui ve - nit in no - mi - ne Do - mi - ni, in no -
 Be - - ne - di - ctus qui ve - nit in no - mi - ne Do -

Tutti *p*

Tutti *p*

Tutti *p*

- mi - ne Do - mi - ni. Be - ne - di - ctus
 - mi - ne Do - mi - ni. Be - ne - di - ctus
 - - - mi - ne Do - mi - ni. Be - ne - di - ctus
 - mi - ni, in no - mi - ne Do - mi - ni. ne - di - ctus qui

no - mi - ne Do - mi - ni, qui ve - nit in no - mi - ne Do - mi - ni.
 no - mi - ne ni, qui ve - nit in no - mi - ne Do - mi - ni.
 no - mi - ne ni, qui ve - nit in no - mi - ne Do - mi - ni, in no

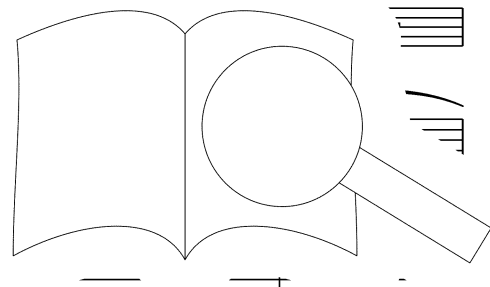

Musical score for measures 54-60. It consists of four staves: three for woodwinds (flute, clarinet, bassoon) and one for strings. The woodwinds have rests, while the strings play a rhythmic accompaniment.

Musical score for measures 61-65. It features woodwinds and strings. The woodwinds play a melodic line, and the strings provide accompaniment. Dynamics include *p* and *cresc.* (crescendo). Instrumentation includes Legni, Cor, and Archi.

Musical score for measures 66-70. It features vocal soloists (Soprano, Alto, Tenor, Bass) and piano accompaniment. The vocalists sing the text: "Be - ne - di - ctus qui ve - nit in no -". The piano accompaniment includes woodwinds and strings. Dynamics include *Solo p*, *decresc.*, and *pp*. Instrumentation includes Archi.

Musical score for measures 71-75. It features vocal soloists and piano accompaniment. The vocalists sing the text: "be - ne - di - ctus mi - ne Do - mi - ni, qui ne - o no - mi - ne Do - mi - ni, qui nit in no - mi - ne Do - mi - ni, qui ve - nit in no - mi - ne D". The piano accompaniment includes woodwinds and strings.

PROBEPARTITUR
 Ausgabqualität gegenüber Original evtl. gemindert • Evaluation Copy - Quality may be reduced • Carus-Verlag

ve - nit in no - mi - ne Do - mi - ni, qui ve - nit in no - mi - ne Do - mi -

ve - nit in no - mi - ne Do - mi - ni, qui ve - nit in no - mi - ne Do - mi -

ve - - - nit in no - mi - ne Do - mi - ni, in no - mi - ne Do - mi -

ve - - - nit in no - mi - ne Do - mi - ni, in no - mi - ne Do - mi -

ni.

ni.

ni.

ni.

Legni, Trb

ne - di - ctus qui

Tutti

Tutti *ff*

Be - ne - di - ctus qui

Tutti

Be -

ve - nit in no - mi - ne Do - mi - ni, in no - mi - ne

mi - ne Do - mi - ni, qui

i - ne

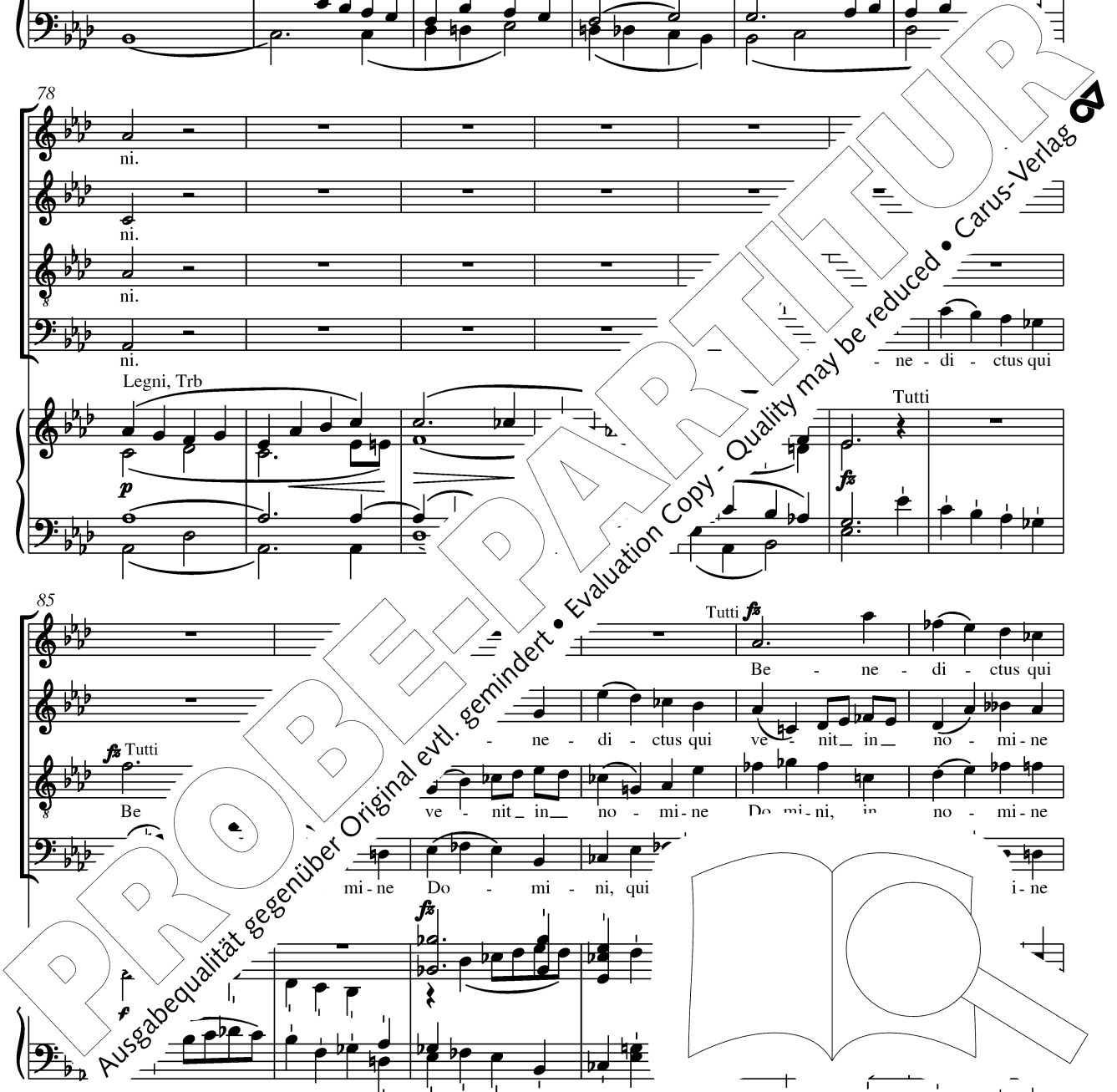

91

decresc. *p* Solo *p*

ve - - - nit. Be - ne - di - ctus qui ve - nit in no - mi - ne

decresc. Solo *p*

Do - mi - ni. Be - ne - di - ctus qui ve - nit, qui ve - nit in no - mi - ne

decresc. *p* Solo

Do - - mi - ni. Be - ne - di - ctus qui ve - nit in no - mi - ne

decresc. *p* Solo

Do - mi - ni. Be - ne - di - ctus qui ve - nit in

97

Do - mi - ni, in no - - - mi - ne Do - mi - ni

Do - mi - ni, in no - - - mi - ne Do - - - ne -

Do - mi - ni, in no - - - mi - ne Do ni

no - mi - ne Do - - - mi - ni, ir

103

di - ctus qui no - ne Do - mi - ni, qui ve - - - nit in

di - ctus - - - mi - ne Do - mi - ni, qui ve - - - nit in

ve mi - ne Do - mi - ni, in no - mi - ne nit in

di - ctus qui ve - nit in no

- mi - ne

no - mi - ne Do - mi - ni.
 no - mi - ne Do - mi - ni.
 no - mi - ne Do - mi - ni.
 Do - - - mi - ni.

Archi
p

115 Allegro, ma non troppo

O - san - na in ex - cel - sis - - - Je - - -
 O - san - - - sis -

Tutti

123

na in ex - cel - sis, De - - - o, in ex - cel - sis, in ex -
 in ex - cel - sis - De - - - o, in ex -
 o, - na, o - san - - - na in ex - cel - sis

Ausgabequalität gegenüber Original evtl. gemindert • Evaluation Copy - Quality may be reduced • Carus-Verlag

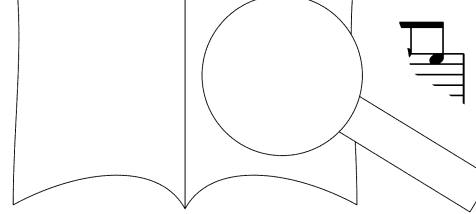

131

cel - sis De - - o, o - san - -

cel - sis De - - o, o - san - - na in ex - cel - -

sis, o - san - - na, o - san - - na in ex - cel - - sis -

na, o - san - na in ex - cel - sis De - - o, o -

139

na, o - san - - na, o - san - - na, o -

sis, o - san - - na, o - san - -

De - - o, o - san - - na, o

san - - na, o - san - - na, ex - cel - -

na in ex -

146

cel - sis o - san - - na in ex - cel - -

o - san - - na, o - san - -

o - san - - na, o - cel - -

- san - na in ex - cel -

o -

PROBEPARTITUR

Ausgabequalität gegenüber Original evtl. gemindert • Evaluation Copy - Quality may be reduced • Carus-Verlag

sis, o - san - na in ex - cel - sis De - o, o -
 na in ex - cel - sis, in ex - cel - sis De - o,
 sis, o - san - na in ex - cel - sis De - o, o - san -
 san - na in ex - cel - sis De - o,

san - na in ex - cel - sis
 o - san - na in ex - cel - sis
 o - san - na in ex -

o, o - san - na.
 o, na.
 o, na.
 san

PROBEPARTITUR
 Ausgabegqualität gegenüber Original evtl. gemindert • Evaluation Copy - Quality may be reduced • Carus-Verlag

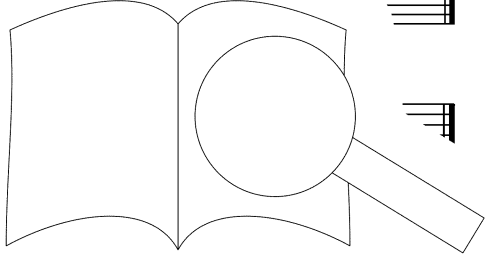

Agnus Dei

Andante con moto

Soprano
Alto
Tenore
Basso

2 Oboi
2 Clarinetti
2 Fagotti
2 Corni
2 Clarini
3 Tromboni
Timpani
Archi
Bassi

Cor *ff*
f Fag, Trb
Va
Vc, Cb

A - gnus De - i, qui

6

gnus De - i, qui tr
De - i, qui tol - lis pec - ca - - ta
- tol - lis pec - ca - ta, ta - mun - di,

11

De - i, qui tol - lis pec - ca - - ta,
ca - mun - di,
A - gnus qui

17

ff

pec - ca - - ta mun - - - di:

ff

pec - ca - - ta mun - - - di:

ff

tol - lis pec - ca - ta mun - - - di:

ff

pec - ca - - ta mun - - - di:

Tutti

24

p

mi - - se - re - - re, mi - se - re - re

p

mi - se - re - - re

p

mi - se - re - - re

p

mi - se - re - - re

Archi

p

Clf

Fag

32

bis.

f

A - - -

bis.

De - - i, qui

bis.

A - - - gnus

PROBEPARTITUR
 Ausgabqualität gegenüber Original evtl. gemindert • Evaluation Copy - Quality may be reduced • Carus-Verlag

gnus De - i, qui tol - lis pec - ca - ta -

tol - lis pec - ca - ta, pec - ca - ta mun - di, A - gnus

De - i, qui tol - lis pec - ca - ta mun - di,

A - gnus De -

ta mun - di,

De - i, qui tol - lis

A - gnus

i, qui tol - lis

qui tol - lis pec - ca - ta, pec - ca - ta

ca - ta

ca - ta

lis

mun - di:

mun - di:

mun - di:

mun - di:

se -

PROBEPARTITUR

Ausgabequalität gegenüber Original evtl. gemindert • Evaluation Copy - Quality may be reduced • Carus-Verlag

58

p mi - - se - re - - re no - - - bis.

p mi - - se - re - - re no - - - bis.

p mi - - se - re - - re no - - - bis.

re - re, mi - se - re - re no - - - bis.

Cltr

Fag

f

65

f A - gnus De

f A - gnus De

f A - gnus De i, lis pec -

Tutti *ff*

ff *ff* *ff*

71

De - - A - -

...us De - - i, qui tol -

i, A - - gnus De - - i,

mun - - di,

gnus De - - i, qui tol - lis pec - ca - ta mun - di,
 - - lis - pec - ca - - ta, pec - ca - - - ta mun - di,
 qui tol - - lis - pec - ca - - - ta mun - di,
 De - - - i, qui tol - lis pec - ca - - - ta mun - di,

A - gnus De - i, pec -
 A - gnus De - i, qui

De - i, qui tol - lis pec - ca - ta mun - di:
 ca - ta mun - di:
 qui tol - lis pec - ca - ta mun - di:
 ca - ta mun - di:

PROBEPARTITUR
 Ausgabequalität gegenüber Original evtl. gemindert • Evaluation Copy - Quality may be reduced • Carus-Verlag

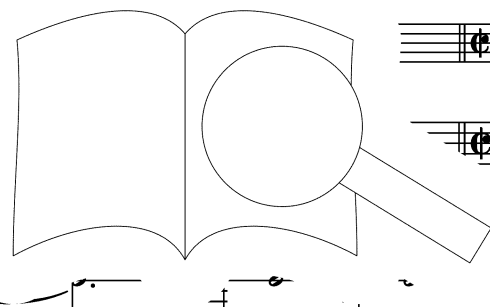

Dona nobis

Andantino

99

do - na no - bis pa - - cem,
do - na no - bis pa - - cem,
do - na no - bis pa - - cem,
do - na no - bis pa - - - cem,

Archi Cor
Fag

104

do - na no - bis pa - - cem,
do - na no - bis pa - - cem,
do - na no - bis pa - - cem,
do - na no - bis pa - -

Archi
Fag, Trb

109

do - na
do - na
do
do
do - na
do - na
do
do

na
na
na
na
na
na
na
na

pa - - cem,
pa - - cem,
pa - - cem,
pa - - cem,
bis pa - - -
pa - - -

Trb

PROBEPARTITUR
Ausgabequalität gegenüber Original evtl. gemindert • Evaluation Copy - Quality may be reduced • Carus-Verlag

114

do - - na, do - na no - bis pa - - - cem,
do - - na, do - na no - bis pa - - - cem,
do - - na, do - na no - bis pa - - - cem,
do - - na, do - na no - bis pa - - - cem,

Archi

Clf, Cor

Fag, Trb

119

do - na no - bis,
do - na no - bis, no
do - na no - bis pa -
do - na bis, no - bis pa -

124

cem,
cem,
cem,
cem,
pa - - - cem,
- cem,

PROBE PART FÜR
Ausgabequalität gegenüber Original evtl. gemindert • Evaluation Copy - Quality may be reduced • Carus-Verlag

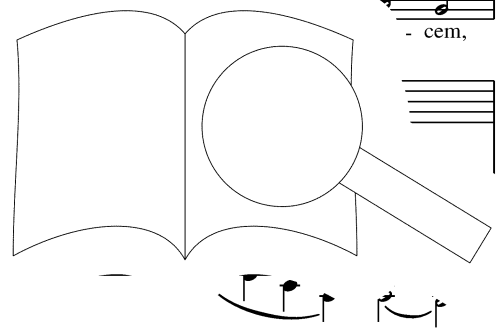

130

do - na, do - na no - bis pa - cem,

do - na, do - na no - bis pa - cem,

do - na, do - na no - bis pa - cem,

do - na no - bis pa - cem, do - na, do - na no - bis pa - cem,

Tutti

135

pa - cem, pa - cem.

pa - cem, pa - cem.

pa - cem, pa - cem.

pa - cem, pa - cem.

pa - cem, pa - cem.

Solo *p*

Do - na,

140

Solo *p*

Solo *p*

Solo *p*

Do - na

Do

na no - bis pa - cem, do - na no - bis

do - na pa - cem, do - na no - bis

no - bis, do - na no - bis

no - bis

no - bis, do - na

no - bis

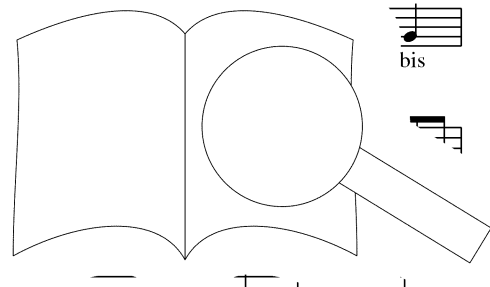

PROBEPARTITUR
Ausgabequalität gegenüber Original evtl. gemindert • Evaluation Copy - Quality may be reduced • Carus-Verlag

pa - cem, do - na, do - na no - bis

pa - cem, do - na, do - na no - bis, do - - na

pa - cem, do - na, do - na no - bis, do - - na

pa - cem, do - na, do - na no - bis pa - - cem, do - - na

decresc.

pa - cem, do - na no - bis pa - cem, pa - cem,

pa - cem, do - na no - bis pa - cem, pa -

pa - cem, do - na no - bis pa - cem, cem,

pa - cem, do - na no - bis pa - cem pa - cem,

Clt, Fag

pp

do - na no - bis,

do - na no - bis pa - - cem, do - na, do - na

do - na no - bis do - na, do - na

do - na

PROBEPARTITUR

Ausgabequalität gegenüber Original evtl. gemindert • Evaluation Copy - Quality may be reduced • Carus-Verlag

Tutti f
 no - bis pa - cem. Do - na, do - na no - bis pa - - - cem.
Tutti f
 no - bis pa - cem. Do - na, do - na no - bis pa - - - cem.
Tutti f
 no - bis pa - cem. Do - na, do - na no - bis pa - - - cem.
Tutti f
 pa - cem. Do - na no - bis, do - na no - bis pa - - - cem.

p *f* *f* *decresc.*

Solo: Do - na no - bis pa - - - cem,
 Tutti: do - na no - bis pa - - - cem,
 Solo: Do - na no - bis pa - - - cem,
 Tutti: do - na no - bis pa - - - cem,
 Solo: Do - na no - bis pa - - - cem,
 Tutti: do - na no - bis pa - - - cem,

Archi

p

do - na no - bis cem,
 cem, do - na do - na do - na no - bis pa - - -
 cem, do - na do - na do - na no - bis pa - - -
 cem, do - na do - na no - bis pa - - -
 bis pa - - -

p

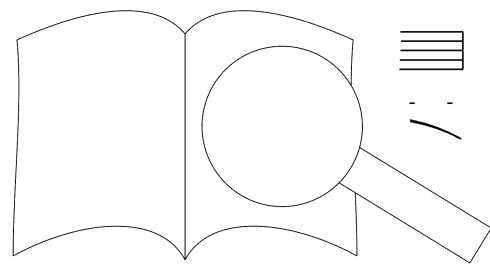

PROBENPARTITUR
 Evaluation Copy - Quality may be reduced • Carus-Verlag



177

do - na no - bis pa - - cem,

cem, do - - na no - bis pa - -

do - na no - bis pa - - cem, f do - - na no - bis pa - -

do - na no - bis pa - - cem, f do - - na no - bis pa - -

cem, do - - na no - bis pa - - cem, f do - - na no - bis pa - -

Archi

+Legni, Cor, Trb

182

do - - na, do - na no - bis pa - - cem,

cem, do - - na no - bis, no - bis pa - - cem, do - na no -

cem, do - - na, do - na no - bis pa - - cem, do - -

cem, do - - na, do - na no - bis pa - - en. no pa - cem,

cem, do - - na, do - na no - bis pa - - bis pa - cem,

Archi

+Legni, Cor, Trb

187

do - na no

do -

do -

do -

do -

do -

cresc.

cresc.

cresc.

cresc.

cresc.

cre.

Allegro molto moderato

Ausgabequalität gegenüber Original evtl. gemindert. Evaluation Copy - Quality may be reduced. Carus-Verlag

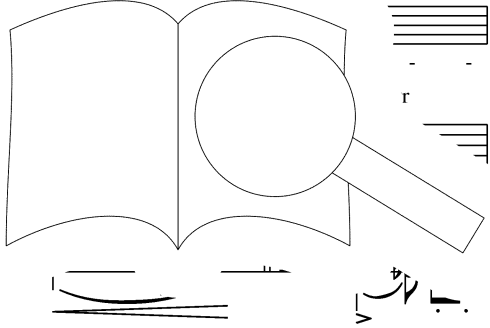

Musical score for measures 192-197. It includes vocal lines for Soprano and Tenor/Bass, and a piano accompaniment. The lyrics are: "gnus De - i, qui tol - lis pec - ca -". Dynamic markings include *f* and *ff*.

Musical score for measures 198-203. It includes vocal lines for Soprano and Tenor/Bass, and a piano accompaniment. The lyrics are: "A - - gnus De - - i, i, qui tol - - lis pec - ca - ta mun - di, ta - mun - di, gnu - i,". Dynamic markings include *f* and *ff*.

Musical score for measures 204-209. It includes vocal lines for Soprano and Tenor/Bass, and a piano accompaniment. The lyrics are: "tol - lis pec di, gnus A - - gnus De - - i, A - - gnus De - - i, A - - gnus De - - i, A - - gnus De - - i, A - - gnus De - - i,". The word "Tutti" appears at the end of the system. Dynamic markings include *ff*.

210

Andantino

decresc. *pp*

A - - - gnus De - i: do - na no - bis pa -

decresc. *pp*

A - - - gnus De - i: do - na no - bis pa -

decresc. *pp*

A - - - gnus De - i: do - na no - bis pa -

decresc. *pp*

A - - - gnus De - i: do - na no - bis pa -

Archi

decresc. *pp*

217

cem, do - na no - bis pa - - cem,

cem, do - na no - bis pa - - do - na

cem, do - na no - bis pa do - na

cem, do - na no - bis do - na

Legni, Cor Archi

Trb

225

cresc.

no - bis pa - no - - bis pa - cem,

cresc.

no - bis na no - - bis pa - cem,

cresc.

no do - na no - - cem, do - na no

p

PROBENPARTITUR

Ausgabequalität gegenüber Original evtl. gemindert • Evaluation Copy - Quality may be reduced • Carus-Verlag

