

Organ works of the 16. bis 18. Jahrhunderts
Orgelwerke

Orgelschule zur historischen Aufführungspraxis
Historical Performance Practice in Organ Playing

Notenband / Music Volume
herausgegeben von / edited by
Jon Laukvik

 Carus 40.511

Einleitung

Dieser Notenband enthält eine Auswahl der in meiner *Orgelschule zur historischen Aufführungspraxis*, Teil 1, behandelten Werke, mit verschiedenen Angaben zur Ausführung versehen. Darüber hinaus wird die bis auf die *Fugue* nicht erörterte *Suite du premier ton* von Louis-Nicolas Clérambault mitgeteilt. Primärer Zweck dieser Publikation ist die Ergänzung zum Textband, sie kann aber auch als eine Sammlung hochwertiger Literatur aus drei Jahrhunderten benutzt werden. Die umkreisten Ziffern im Notentext beziehen sich auf Angaben im Textband.

Nachfolgend einige skizzenhafte Informationen zu den Komponisten:

Der englische Virtuose **John Bull** (geb. um 1562, gest. 1628 in Antwerpen) trat nach seiner Tätigkeit als Organist der Königlichen Kapelle von Elisabeth I. 1613 in die Dienste von Erzherzog Albrecht in Brüssel; ab 1617 war er Kathedralorganist in Antwerpen. Seine Werke für Tasteninstrumente sind u. a. im *Fitzwilliam Virginal Book* und im *Cosyn's Virginal Book* überliefert.

Johannes (oder **Hans**) **Buchner** (geb. 1483 in Ravensburg, gest. 1538 in Konstanz) war ein Schüler Paul Hofhaimers. Er wurde 1506 Domorganist in Konstanz, im Zuge der Reformation übernahm er 1526 das Organistenamt am Münster in Überlingen. Sein *Fundamentum* enthält Anleitungen zu Orgelspiel, Improvisation und Intavolierung.

Jan Pieterszoon Sweelinck (geb. 1562 in Deventer, gest. 1621 in Amsterdam) versah ab etwa 1580 den Organistendienst an der Oude Kerk in Amsterdam. Er unterrichtete viele deutsche Schüler, vornehmlich aus dem norddeutschen Flachland, daher wurde er der „deutsche Organistenmacher“ genannt.

Girolamo Frescobaldi, 1583 in Ferrara geboren und ab 1604 in Rom ansässig, erreichte nie sein ersehntes Ziel, ein abwechslungsreiches Leben als Hofmusiker führen zu können, sondern blieb, hochgeehrt, Organist an St. Peter in Rom bis zu seinem Tode im Jahre 1643. Sein überliefertes Œuvre besteht fast ausschließlich aus Werken für Tasteninstrumente.

Louis-Nicolas Clérambault (geb. 1676 in Paris, gest. ebd. 1749) war ein Schüler von André Raison und Organist am Jakobinerkonvent und an St. Sulpice in seiner Geburtsstadt. Neben den hier mitgeteilten Orgelstücken besitzen wir von ihm u. a. Kantaten und Kammermusik.

Georg Muffat, Angehöriger einer schottisch-englischen Familie, wurde 1653 in Megève (Savoyen) geboren. Die wichtigsten Stationen seines Lebens waren Paris, Wien und Salzburg. Er starb 1704 in Passau als Kapellmeister am bischöflichen Hof. Seine beiden *Florilegia* (1695 in Augsburg bzw. 1698 in Passau gedruckt) enthalten aus Ouverturen und Tanzsätzen bestehende Orchestersuiten.

Francisco Correa de Arauxo wurde 1584 in Sevilla geboren und starb 1654 in Segovia. Wie Girolamo Frescobaldi scheint er eine unbequeme Persönlichkeit gewesen zu sein; mit den Klerikern der Kirche San Salvador zu Sevilla, an welcher er das Organistenamt bekleidete, hatte er erhebliche Auseinandersetzungen. Sein umfangreiches *Libro de Tientos ... intitulado Facultad Organica* von 1626 enthält auch einen Textteil mit Angaben u. a. zu Fingersatz und Ornamentik.

Henry Purcell, 1659 in London geboren und dort 1695 gestorben, war schon in jungen Jahren außergewöhnlich erfolgreich; bereits 1679 folgte er seinem Lehrer John Blow im Organistenamt an der Westminster Abbey. 1682 wurde er an die Königliche Kapelle berufen. Er schrieb vor allem Kammer- und Bühnenwerke und strebte eine Synthese der englischen polyphonen Tradition und der stilistischen Neuerungen der hochbarocken kontinentalen Musik an.

Der als Improvisator berühmte **Louis Marchand** (geb. 1669 in Lyon, gest. 1732 in Paris) hatte u. a. eine Stelle als Organist der Königlichen Kapelle Ludwigs XV. inne, mußte aber um 1717 wegen seines ausschweifenden Lebenswandels eine gewisse Zeit Frankreich verlassen. Von Marchand sind auch Cembalowerke überliefert.

Der zweitälteste Sohn Johann Sebastian Bachs, **Carl Philipp Emanuel Bach** (geb. 1714 in Weimar, gest. 1788 in Hamburg) war eine sehr erfolgreiche Persönlichkeit. Er beschloß nach einer knapp 30jährigen Tätigkeit als Hofmusiker Friedrichs des Großen seine Laufbahn als Musik-

direktor der Hamburger Kirchen. Neben zahlreichen Clavierwerken sind vor allem seine Passionen bedeutend.

Den im Kritischen Bericht genannten Bibliotheken, die bereitwillig Quellenmaterial zur Verfügung gestellt haben, spreche ich an dieser Stelle meinen herzlichen Dank aus.

Stuttgart, im Sommer 1989

Jon Laukvik

Introduction

The present volume of music contains a selection of the works referred to in Part 1 of my *Historical Performance Practice in Organ Playing*, together with instructions for their performance. The present collection also includes the *Suite du premier ton* by Louis-Nicolas Clérambault, which, with the exception of the *Fugue*, is not discussed in this book. Apart from its primary purpose of providing musical material required for the organ course, the publication can also be utilized as a collection of interesting music literature from three centuries. The numbers within circles in the music correspond to references in the text volume.

Some brief details concerning the composers:

The English keyboard virtuoso **John Bull** (born ca. 1562, died in Antwerp in 1628) was organist of the Chapel Royal under Elizabeth I. From 1613 he served as a musician at the court of Archduke Albrecht in Brussels and in 1617 he became cathedral organist at Antwerp. His pieces for keyboard instruments are contained in collections including the *Fitzwilliam Virginal Book* and *Cosyn's Virginal Book*.

Johannes (or **Hans**) **Buchner** (born in Ravensburg in 1483, died in Constance in 1538) was a pupil of Paul Hofhaimer. In 1506 he became cathedral organist at Constance and in 1526, following the Reformation, he took over the position of organist at the Minster in Überlingen. His *Fundamentum* contains instructions on organ playing, improvisation and intavolatura.

Jan Pieterszoon Sweelinck (born in Deventer in 1562, died in Amsterdam in 1621) became organist at the Oude Kerk, Amsterdam, about 1580. He taught many German pupils, mainly from the north-German plain, with the result that he became known as the "German organist maker."

Girolamo Frescobaldi, born at Ferrara in 1583 and resident in Rome from 1604, never attained his intended goal of living a life full of variety as a court musician, instead he remained the highly esteemed organist at St. Peter's, Rome, until his death in 1643. His surviving oeuvre consists almost exclusively of works for keyboard instruments.

Louis-Nicolas Clérambault (born in Paris in 1676, died there in 1749) was a pupil of André Raison and became organist at the Jacobin Convent and St. Sulpice in Paris. Works of his in addition to the organ pieces in this collection include cantatas and chamber music.

Georg Muffat, who came of a Scottish-English family, was born at Megève (Savoy) in 1653. The important stations of his career were in Paris, Vienna and Salzburg. He died in 1704 in Passau, where he was *Kapellmeister* at the Bishop's court. His two *Florilegia* (published in 1695 and 1698 at Augsburg and Passau, respectively) contain orchestral suites which consist of overtures and dance movements.

Francisco Correa de Arauxo was born in 1584 and died in 1654 at Segovia. Like Girolamo Frescobaldi he seems to have been a difficult person and he had serious disagreements with the clergy of the Church of San Salvador in Seville, where he was the organist. His *Libro de Tientos ... intitulado Facultad Organica* of 1626 includes a section of instruction on such matters as fingering and ornamentation.

Henry Purcell (born in London 1659, died there in 1695) was musically successful at an astonishingly young age. As early as 1679 he succeeded his teacher John Blow as organist of Westminster Abbey and in 1682 he became organist of the Chapel Royal. He wrote principally chamber music and music for the theatre and he strove to create a synthesis of the English polyphonic tradition and the stylistic innovations of high-baroque continental composers.

Louis Marchand (born in Lyon in 1669, died in Paris in 1732), who was famed as an improvisator, held a number of posts, including that of organist at the Royal Chapel of Louis XV. About 1717, however, he was banished from France for a time, owing to his scandalous life. Music by Marchand which has survived also includes works for harpsichord.

The second son of Johann Sebastian Bach, **Carl Philipp Emanuel Bach** (born in Weimar in 1714, died in Hamburg in 1788), was an extremely successful personality who spanned the period between the baroque and classical eras. He worked for thirty years as a court musician to

Frederick the Great of Prussia, then concluded his career as director of music for the churches of Hamburg. The most important compositions are numerous keyboard works, and above all his Passions.

I wish to express my heartfelt thanks to the libraries named in the Critical Report, whose directors kindly made the source material available for the present publication.

Stuttgart, summer 1989

Translation: John Coombs

Jon Laukvik

Critical Report

The Edition

Editorial additions are identified in the musical text as follows: slurs are printed as dotted lines; all instructions using letters (*t* or *tr* ornament signs, dynamic markings, performance and tempo indications) are printed in italics. Rests are added only when indispensable, principally in polyphonic movements. They are indicated in small print, as are additional accidentals (including "warning accidentals") of the editor. Accidentals apply to the whole bar. Exceptions to this rule are the pieces by Bull, Buchner, Correa de Arauxo and Frescobaldi, which were composed during the transitional period between the eras of modal and gradually consolidating major-minor tonality. For an accidental to apply to the whole bar would obscure important features of these works. Additional ornaments are either in small print or are in brackets. The layout of the music generally follows the sources, as it can give information for performance (articulation, punctuation). Bar lines have been inserted in accordance with modern practice, even if they do not occur in the source. Bar and movement numbers have been added by the editor.

Exceptions to the basic principles outlined above and special cases are noted and explained where they occur.

The suggestions regarding the execution of ornaments are self-explanatory. The order in which the pieces are given corresponds to the contents of the text volume; in order to avoid a bad page turn, the *Fond d'orgue* by Louis Marchand is printed on page 62.

For special remarks see p. 72.

Avant-propos

Ce volume de musique contient une sélection des œuvres étudiées dans mon *Orgelschule zur historischen Auführungspraxis*, vol. 1. Nous avons ajouté, par ailleurs, la *Suite du premier ton* de Louis-Nicolas Clérambault. Le recueil est certes destiné en premier lieu à compléter le volume de texte de notre ouvrage propédeutique. Mais il peut aussi être utilisé comme une anthologie couvrant trois siècles de musique. Les chiffres entourés d'un cercle dans la partition se rapportent à des indications données dans le volume de texte.

Voici quelques rapides informations sur les compositeurs : Le virtuose anglais **John Bull** (né vers 1562, mort en 1628 à Anvers) fut organiste à la chapelle royale d'Elisabeth 1^{ère}. En 1613 il entre au service de l'archiduc Albert à Bruxelles, puis à partir de 1617 il est organiste à la Cathédrale d'Anvers. Ses œuvres pour les instruments à clavier sont transmis, entre autres, dans le *Fitzwilliam Virginal Book* et le *Cosyn's Virginal Book*.

Johannes (ou **Hans**) **Buchner** (né en 1483 à Ravensburg, mort en 1538 à Constance) était un élève de Paul Hofhaimer. Il fut engagé en 1506 comme organiste à la cathédrale de Constance. Après la Réforme il devint organiste à la cathédrale de Überlingen. Son *Fundamentum* contient des instructions pour le jeu de l'orgue, l'improvisation et la mise en tabulature.

Jan Pieterszoon Sweelinck (né en 1562 à Deventer, mort en 1621 à Amsterdam) fut organiste à partir de 1580 environ à la Oude Kerk à Amsterdam. Il enseigna l'orgue à de nombreux élèves allemands, originaires en particulier d'Allemagne du nord. Il fut ainsi qualifié de « faiseur d'organistes allemands ».

Girolamo Frescobaldi, né à Ferrare en 1583, résida à Rome à partir de 1604. Il ne parvint jamais à réaliser son rêve de mener l'existence mouvementée de musicien de cour. Il demeura ainsi, jusqu'à sa mort survenue en 1643, l'organiste très apprécié de St Pierre de Rome. Son œuvre se compose presque exclusivement de compositions pour les instruments à clavier.

Louis-Nicolas Clérambault (né en 1676 à Paris, mort à Paris en 1749) avait été l'élève d'André Raison et fut organiste au convent des Jacobins et à St Sulpice à Paris. Outre les pièces pour orgue que nous publions ici, il a également laissé des cantates et des œuvres de musique de chambre. Issu d'une famille anglo-écossaise, **Georg Muffat** est né en 1653 à Mégève (Savoie). Paris, Vienne et Salzbourg ponctuèrent les principales étapes de son existence. Il est mort en 1704 à Passau comme maître de chapelle à la cour épiscopale. Ses deux *Florilegia* (imprimés respectivement en 1695 à Augsbourg et en 1698 à Passau) contiennent des suites pour orchestre formées d'ouvertures et de danses.

Francisco Correa de Arauxo est né en 1584 à Séville et mort en 1654 à Segovie. Il paraît avoir été un personnage difficile. Une longue querelle l'opposa au clergé de l'église San Salvador de Séville où il avait une charge d'organiste. Son volumineux *Libro de Tientos ... intitulado Facultad Organica* de 1626 contient également des textes donnant des indications concernant les doigtés et l'ornementation.

Henry Purcell, né en 1659 à Londres et y mort en 1695, connut une jeunesse comblée de succès. Dès 1679 il succéda à son maître John Blow à la fonction d'organiste à Westminster Abbey. En 1682 il fut appelé à la chapelle royale. Il composa de remarquables œuvres pour la scène et engagea une synthèse entre la tradition polyphonique anglaise et les innovations stylistiques de la musique baroque continentale.

Louis Marchand (né en 1669 à Lyon et mort en 1732 à Paris), célèbre pour ses talents d'improvisateur, était, entre autres, titulaire de l'orgue de la chapelle royale de Louis XV. En 1717 il fut toutefois contraint à un exil temporaire en raison de sa vie dissolue. L. Marchand a également composé des œuvres pour le clavecin.

Le second fils aîné de Jean Sébastien Bach, **Carl Philipp Emanuel Bach** (né en 1714 à Weimar, mort en 1788 à Hambourg), est injustement considéré comme une figure marginale de l'histoire de la musique. Cette personnalité à succès située à la charnière du Baroque et de l'Époque classique termina sa carrière comme Directeur de la musique des églises de Hambourg après avoir travaillé durant près

de 30 ans à la cour de Frédéric le Grand. Outre ses nombreuses œuvres pour le clavier, ce sont avant tout ses passions qui retiennent l'attention.

Je tiens enfin à adresser ma gratitude à toutes les Bibliothèques citées dans l'apparat critique que ont mis si généreusement les sources à ma disposition.

Stuttgart, été 1989

Jon Laukvik

Traduction : Christian Meyer

Apparat critique

L'édition

Les additions de l'éditeur sont signalées de la manière suivante dans les partitions : traits de liaison en pointillés, toutes les indications littérales (signes d'ornementation – *t* ou *tr* –, signes dynamiques, indication de jeu et de tempo) sont mises en italiques. Les silences n'ont été ajoutés qu'en cas d'extrême nécessité, en particulier dans les mouvements polyphoniques. Ils apparaissent en petite gravure ainsi que les altérations accidentelles (également les « altérations de rappel » ajoutées par l'éditeur. Les altérations valent pour la mesure toute entière à l'exception des pièces de Bull, Buchner, Correa de Arauxo et Frescobaldi. En raison de l'« hésitation » entre la modalité et la polarité tonale majeur-mineur qui ne se développe que progressivement, la disposition des altérations par unité de mesure occulterait des caractéristiques essentielles de ces pièces. Les signes d'ornementation supplémentaires sont imprimés soit en petits caractères, soit placés entre crochets. Les barres transversales suivent en principe le modèle, dans la mesure où elles peuvent apporter des indications d'exécution (phrasé, interponction). Les barres de mesure sont disposées conformément aux usages actuels, même lorsqu'elles manquent dans le document original. La numérotation des mesures et des pièces est le fait de l'éditeur.

Les exceptions à ces principes et certains cas particuliers sont signalés et expliqués cas par cas.

Les suggestions d'exécution pour les ornements devraient également être compréhensibles sans explication. La succession des pièces correspond au plan du volume de texte : pour des raisons de tourne de page, le *Fond d'orgue* de Louis Marchand n'a été imprimé qu'à la page 62.

Pour les remarques de détail, voir p. 72.

3

2 *Preludium*

(?): A preludium. Royal College of Music, London, Sign.: MS 2093, f. 3^v

PROBEPARTITUR

Ausgabequalität gegenüber Original evtl. gemindert • Evaluation Copy - Quality may be reduced • Carus-Verlag

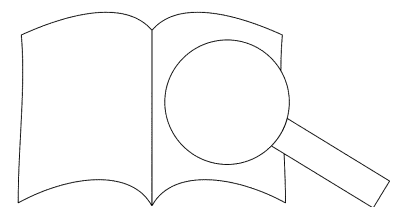

Applicatio I. N. I.



PROBEPARTITUR

Evaluation Copy - Quality may be reduced • Carus-Verlag

pp, ... dem Clavier-Büchlein vor Wilhelm Friedemann Bach.
... University,
... uscript Library, New Haven, USA

J. S. Bach: *Applicatio* (BWV 994) from the *Clav.*
Autograph in possession of Yale University,
Beinecke Rare Book & Manuscript Library, New

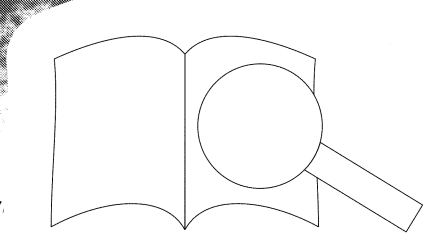

A preludium

Musical notation for measures 1-4. Measure 1: Treble clef, G4, A4, B4, C5, B4, A4, G4. Bass clef, C3, G2, C3. Measure 2: Treble clef, G4, A4, B4, C5, B4, A4, G4. Bass clef, C3, G2, C3. Measure 3: Treble clef, G4, A4, B4, C5, B4, A4, G4. Bass clef, C3, G2, C3. Measure 4: Treble clef, G4, A4, B4, C5, B4, A4, G4. Bass clef, C3, G2, C3.

Musical notation for measures 5-8. Measure 5: Treble clef, G4, A4, B4, C5, B4, A4, G4. Bass clef, C3, G2, C3. Measure 6: Treble clef, G4, A4, B4, C5, B4, A4, G4. Bass clef, C3, G2, C3. Measure 7: Treble clef, G4, A4, B4, C5, B4, A4, G4. Bass clef, C3, G2, C3. Measure 8: Treble clef, G4, A4, B4, C5, B4, A4, G4. Bass clef, C3, G2, C3.

Musical notation for measures 9-12. Measure 9: Treble clef, G4, A4, B4, C5, B4, A4, G4. Bass clef, C3, G2, C3. Measure 10: Treble clef, G4, A4, B4, C5, B4, A4, G4. Bass clef, C3, G2, C3. Measure 11: Treble clef, G4, A4, B4, C5, B4, A4, G4. Bass clef, C3, G2, C3. Measure 12: Treble clef, G4, A4, B4, C5, B4, A4, G4. Bass clef, C3, G2, C3.

en 2 Angaben im Textband. / The circled numbers refer to information in the text volume.

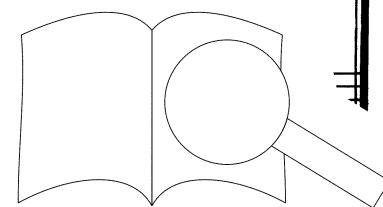

Quem terra pontus

Joh- hner

PROBE PARTITUR
Ausgabequalität gegenüber Original evtl. gemindert • Evaluation Copy - Quality may be reduced • Carus-Verlag

17

22

27

32

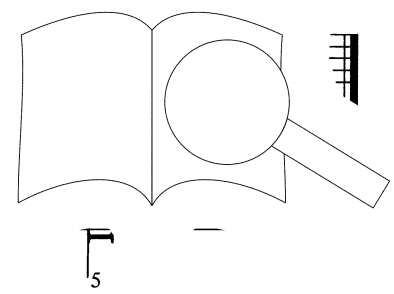

Applicatio

BWV 994

Johann Sebastian Bach
1685–17

Ballo del granduca

Variatio

Jan Pieterszoon Sweelinck
1562–1621

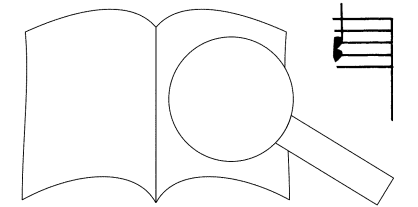

15

3 5 5 5

1. 2.

21

Secunda variatio

5 4 3 2 4 2 4 2 3 2 1 2 3 4 3 4 [5] 4 2 4 2 3 2 3 4 3 2 3 4 5

1 2 4 1 2 4

28

3 3 2 1

34

[2 3 4] 3 3 4

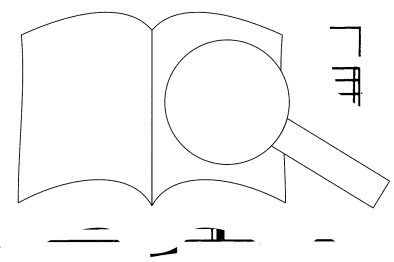

Tertia variatio

41

5 1 5 2 4 2 1 2 1 4 3 2 1 2 1 2 1 4 3 2 1 2 1 2 1 5

1. 2.

47

2 7 7 7 7 7 7

1. 2.

54

7 7 7 7 7 7 7

1. 2.

6

3 3 4 3 4 3 4 5 2 5 4 3 2 3 2 2 3 2 1. 1. 1. 1.

PROBEPARTITUR
Ausgabequalität gegenüber Original evtl. gemindert • Evaluation Copy - Quality may be reduced • Carus-Verlag

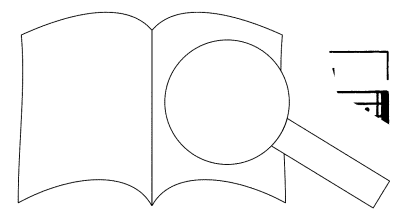

64 2.

68

72

76

PROBEPARTITUR
Ausgabequalität gegenüber Original evtl. gemindert • Evaluation Copy - Quality may be reduced • Carus-Verlag

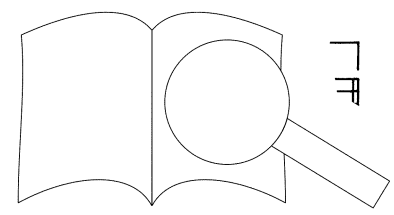

Quinta variatio

81 $\frac{4}{2}$ $\frac{4}{2}$ etc. 2 1

88

95

Praeludium
BWV 870a

Johann Sebastian Bach
1685–1750

8

5 5 5 5 (3) 5 2 3 5 5 2 5 5 2 5 5 2

2 3 1 1 3 1 3 1 3 1 3 1 3 1 2 1

1 1 1 1 1 1 1 1 1 1 1 1 1 1 2 1

5 4 5 2 1 2 1 4 1 4 4 4 1 5 5 4 5 4 4

9 2 3 5 5 2 5 (4) 5 4 5 5 2 5 4

1 1 3 1 2 1 1 1 1 1 1 1 1 1 1 1 2

2 4 5 3 1 4 1 3 3 1 3 2 1 1 2 1 1 2

4 2 5 4 2 5 4 2 5 4 2 5 4 2 5 4 2 5

13 2 5 5 5 (6) 5 5 3 4 5 5 2 4 5 2 3 2 5

1 1 1 1 2 2 3 1 1 1 1 1 1 1 1 1 3 2 5

5 5 5 4 1 1 1 1 1 1 1 1 1 1 1 1 1 1 1 1

5 5 5 4 5 5 4 5 5 4 5 4 5 4 5 4 5 4 5

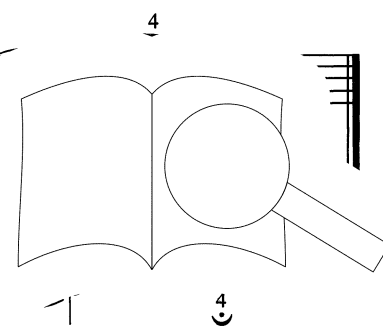

Praeludium in c

BWV 847

Johann ^c Bach
168^r

Measures 1-3 of the Praeludium in c. The piece is in C minor, 2/4 time. The right hand features a melodic line with grace notes and slurs, while the left hand provides a steady bass line with a '2' fingering in the second measure.

Measures 4-6 of the Praeludium in c. The right hand continues the melodic development with slurs and ties. The left hand maintains the bass line with a '2' fingering in the fifth measure.

Measures 7-9 of the Praeludium in c. The right hand has a '2' fingering in the seventh measure. The left hand continues the bass line with a '2' fingering in the ninth measure.

Measures 10-12 of the Praeludium in c. The right hand has a '2' fingering in the tenth measure. The left hand continues the bass line with a '2' fingering in the twelfth measure.

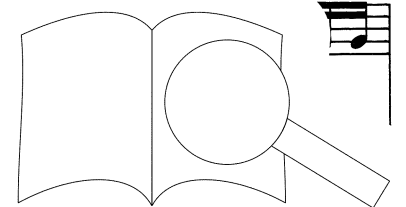

PROBEPARTITUR
Ausgabequalität gegenüber Original evtl. gemindert • Evaluation Copy - Quality may be reduced • Carus-Verlag

13

16

19

22

25

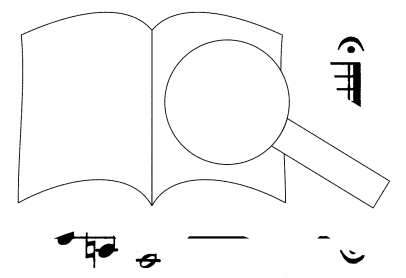

PROBE PARTIUR
Ausgabequalität gegenüber Original evtl. gemindert • Evaluation Copy - Quality may be reduced • Carus-Verlag

Toccata terza (1° libro)

Girolamo
15°
Baldi

① *Langsam / Slowly*



④ *Bewegter / More spirited*

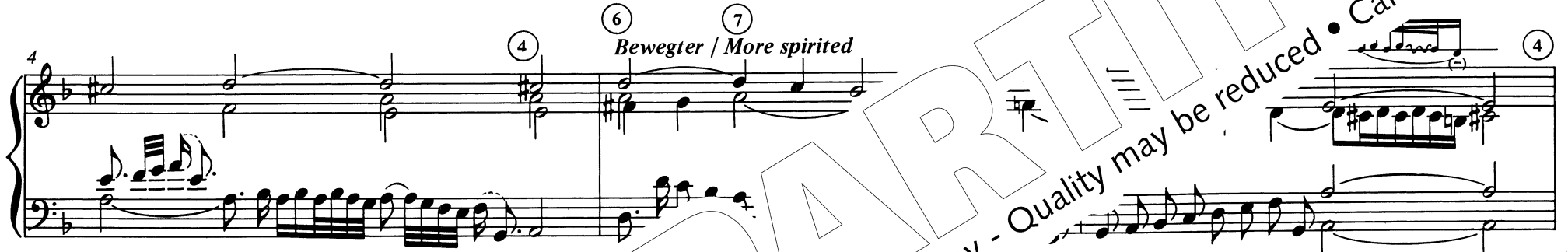

⑨ *Ruhig / Calm*

Festes Zeitmaß / Strict tempo

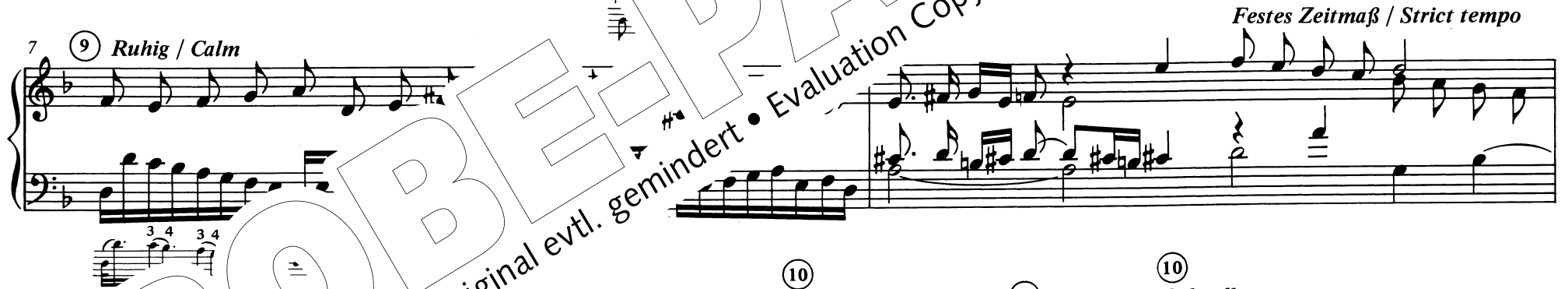

⑩ *Schnell*

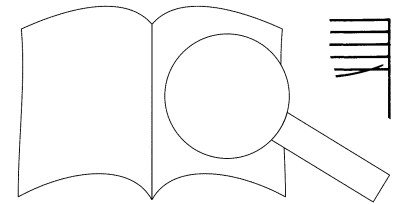
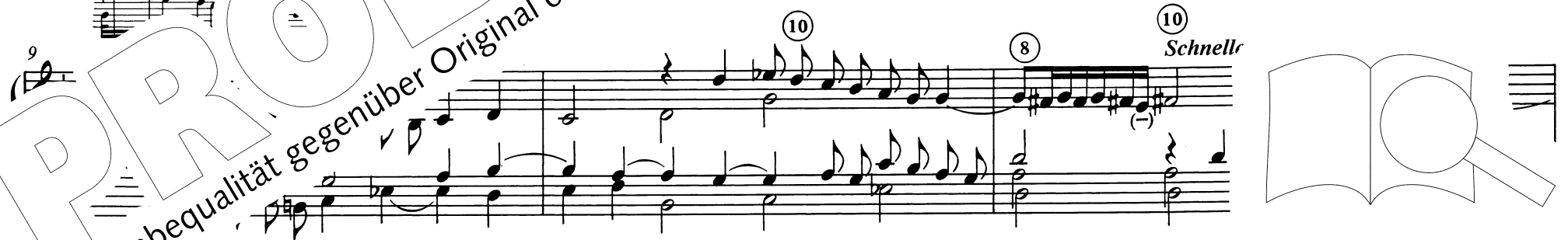

12

2 8

14

11 *Ruhig / Calm*

16

12

18

10

8 *Schneller / Faster*

20

8

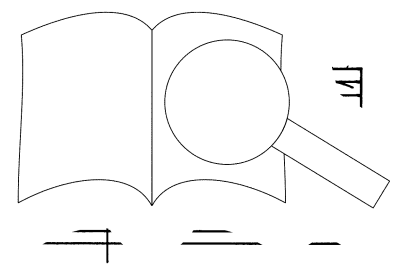

22

Musical notation for measures 22-25. Measure numbers 13, 8, and 11 are circled above the staff. The music is in a piano style with a flowing melody in the right hand and a supporting bass line in the left hand.

24

Musical notation for measures 24-25. Measure number 14 is circled above the staff. The music continues with a similar piano texture.

26 *Flüssig / Flowing*

Musical notation for measures 26-27. Measure number 2 is circled above the staff. The tempo/mood is indicated as *Flüssig / Flowing*. The right hand has a more active, flowing melody.

28 *Lang*

Musical notation for measures 28-31. Measure number 2 is circled above the staff. The tempo/mood is indicated as *Lang*. The music becomes more spacious and slower.

30

Musical notation for measures 30-33. Measure numbers 10 and 14 are circled above the staff. The music continues with a similar piano texture.

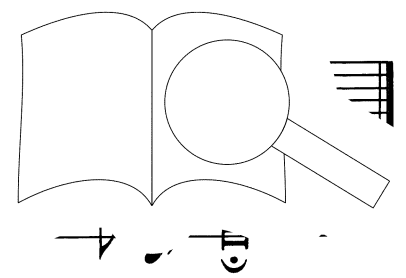

PROBEPARTITUR

Ausgabequalität gegenüber Original evtl. gemindert • Evaluation Copy - Quality may be reduced • Carus-Verlag

Suite du premier ton

I. Grand plein jeu

Fort lentement

Louis-Nicolas
1676-1717

On pourra jouer cette Basse sur la Pédale de Trompette si l'on veut*

13

24

35

* 1. ^{can} auf dem Pedal mit der Trompete gespielt werden./
played on the pedal with the Trumpet.

2. Fugue

Lentement

Musical notation for measures 1-4 of the 2nd Fugue. The score is in C major, 3/4 time, and marked 'Lentement'. The right hand features a complex melodic line with many sixteenth notes and slurs. The left hand provides a steady accompaniment. Measure numbers 1, 2, and 3 are circled above the staff.

Musical notation for measures 5-8 of the 2nd Fugue. The right hand continues with intricate melodic patterns, including slurs and ties. The left hand maintains its accompaniment. Measure numbers 1, 4, and 5 are circled above the staff.

Musical notation for measures 9-16 of the 2nd Fugue. The right hand features a long, flowing melodic line with a slur. The left hand continues with its accompaniment. Measure number 5 is circled above the staff.

PROBEPARTITUR
Ausgabequalität gegenüber Original evtl. gemindert • Evaluation Copy - Quality may be reduced • Carus-Verlag

13

Musical notation for measures 13-16, featuring a treble and bass staff with various notes and rests.

17

Musical notation for measures 17-20, featuring a treble and bass staff with various notes and rests. A circled number 5 is present above the treble staff in measure 19.

21

Musical notation for measures 21-24, featuring a treble and bass staff with various notes and rests. Circled numbers 7 and 5 are present above the treble staff in measures 21 and 23 respectively.

25

Musical notation for measures 25-28, featuring a treble and bass staff with various notes and rests.

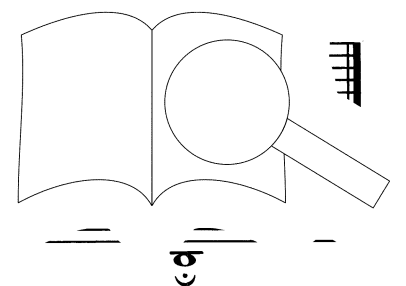

3. Duo

Gayement et gracieusement

Musical notation for measures 1-7. The piece is in 3/8 time. The right hand features a melodic line with grace notes and slurs, while the left hand provides a rhythmic accompaniment with eighth notes and rests.

Musical notation for measures 8-14. The right hand continues the melodic line with slurs and grace notes. The left hand accompaniment includes some chords and eighth notes.

Musical notation for measures 15-22. The right hand has a more active melodic line with many grace notes. The left hand accompaniment consists of eighth notes and rests.

Musical notation for measures 23-29. The right hand continues with a melodic line and grace notes. The left hand accompaniment features eighth notes and rests.

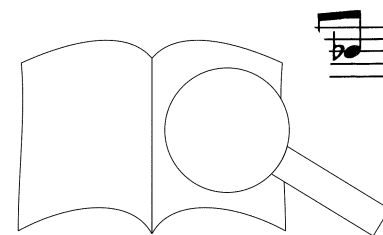

30

Musical notation for measures 30-36. The system consists of a grand staff with a treble clef on the upper staff and a bass clef on the lower staff. The music features a steady eighth-note accompaniment in the bass and a more melodic line in the treble with various ornaments and slurs.

37

Musical notation for measures 37-43. The system continues with the grand staff format. The treble staff shows a melodic line with several trills and slurs, while the bass staff provides a consistent accompaniment.

44

Musical notation for measures 44-51. The system continues with the grand staff format. The treble staff features a melodic line with trills and slurs, and the bass staff continues with the accompaniment.

52

Musical notation for measures 52-58. The system continues with the grand staff format. The treble staff features a melodic line with trills and slurs, and the bass staff continues with the accompaniment. The tempo marking "Lentement" is placed above the staff.

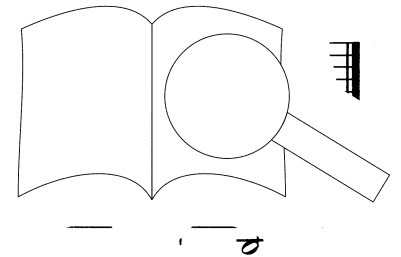

4. Trio

Gratueusement

Cromorne
au positif

Tierces
au grand
jeu

Musical notation for measures 1-6. The score is for two staves: the upper staff is for 'Cromorne au positif' and the lower staff is for 'Tierces au grand jeu'. The music is in 2/2 time and features a melodic line with various ornaments and a bass line with chords and single notes.

Musical notation for measures 7-13. The notation continues from the previous system, showing the progression of the melodic and bass lines.

Musical notation for measures 14-20. The notation continues, showing the melodic and bass lines with various ornaments and dynamics.

Musical notation for measures 21-26. The notation continues, showing the melodic and bass lines. The final measure (26) includes a graphic of an open book with a magnifying glass over it, indicating a specific detail or ending.

PROBEPARTITUR
Ausgabequalität gegenüber Original evtl. gemindert • Evaluation Copy - Quality may be reduced • Carus-Verlag

28

35

42

49

Lentem

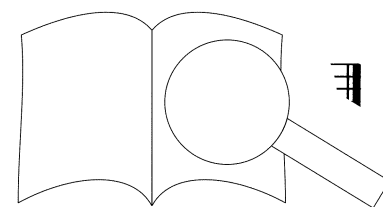

5. Basse et Dessus de Trompette, ou de Cornet séparé, en Dialogue

Gayement

Jeu doux

6

Basse

12

Dessus

Jeu doux

18

Jeu doux

Basse

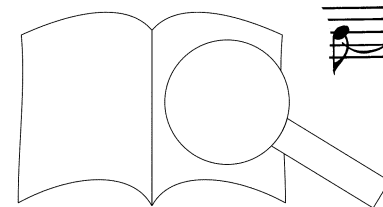

24

Dessus

Jeu doux

30

Casse

36

Ensemble

On pourra répéter cecy si l'on veut*

42

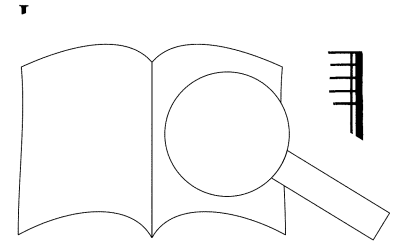

* tr tr Belieben wiederholen./
 (bars) if desired.

6. Récits de Cromorne, et de Cornet séparé, en Dialogue

Doucement et gracieusement

Cromorne

23

Cornet

31

Cromorne

38

Flüte

45

52

7. Dialogue sur les grands jeux

Fort grave

Ceux qui n'auront point de Cornet séparé pourront se servir du Positif pour toucher le dessus dans les endroits qui sont doux*

Grand jeu

7

Gay Cor

romorne au Positif

15

23

*in Cornet séparé haben, können sich an leisen Stellen des Positivs bedienen./Those who have no Cornet séparé, can, in the soft section use the Positif

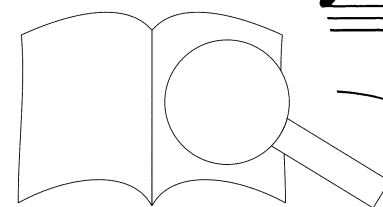

31 *Cornet séparé*

Positif

39

47 *Positif*

Grand jeu

55

64 *Fort lentement*

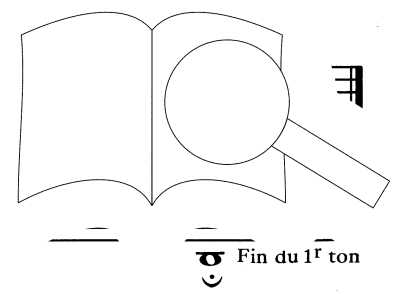

Suite du deuxième ton

1. Plein jeu

Musical score for measures 1-7. The piece is in 2/4 time and B-flat major. Measure 1 is marked with a circled '1'. Measures 2 and 3 are marked with circled '2's. Measure 3 has two versions, 'a.' and 'b.', with a circled '3' above. Measure 4 is marked with a circled '4'. The text 'Petit plein jeu au Positif' is written in the left hand. The right hand has a '3' above measure 3 and a '4' above measure 4. The word 'Loui' is written above measure 7, and 'ault' is written to the right of the staff.

Musical score for measures 8-13. Measure 8 is marked with a circled '5' and the word 'Lenter'. Measure 9 has a circled '5' above. Measure 10 has a circled '4' above. Measure 11 has a circled '3' above. The text 'in jeu' is written in the left hand. The right hand has a circled '4' above measure 10 and a circled '3' above measure 11.

Musical score for measures 14-17. Measure 14 is marked with a circled '8' above. Measure 15 is marked with a circled '9' above. The right hand has a circled '8' above measure 14 and a circled '9' above measure 15. To the right of the staff is a graphic of an open book with a magnifying glass over it.

21 **9** **10** **11**
Gay
Positif

28

34

40 **13** **14** **15**
Fort lentement

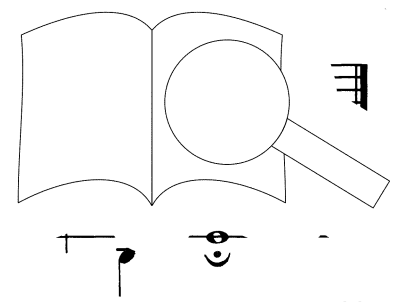

PROBE
Ausgabequalität gegenüber Original evtl. gemindert

Evaluation Copy - Quality may be reduced • Carus-Verlag

2. Duo
Gay

Musical notation for measures 1-6. The piece is in 2/4 time with a key signature of one flat (B-flat). The right hand features a melodic line with eighth and sixteenth notes, while the left hand provides a bass line with quarter and eighth notes. Measure 5 contains a first ending bracket labeled '1'.

Musical notation for measures 7-13. The right hand continues the melodic line with eighth notes and some trills. The left hand has a steady bass line. Measure 11 contains a second ending bracket labeled '2'.

Musical notation for measures 14-19. The right hand has a more active melodic line with eighth notes. The left hand has a bass line with some chromatic movement. Measure 15 contains a third ending bracket labeled '3', and measure 17 contains a second ending bracket labeled '2'.

Musical notation for measures 20-29. The right hand has a melodic line with eighth notes and trills. The left hand has a bass line with some chromatic movement. Measure 20 contains a first ending bracket labeled '1'. Measure 29 contains a second ending bracket labeled '2'.

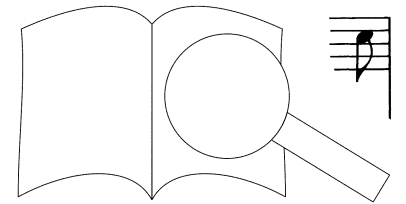

27

35

43

51

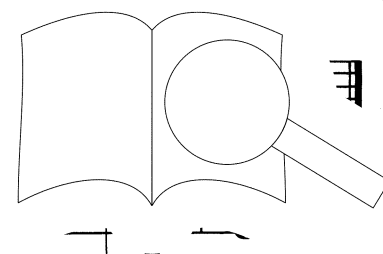

3. Trio

Gracieusement

Musical notation for measures 1-8. The piece is in 3/8 time and B-flat major. The right hand features a melodic line with grace notes and slurs, while the left hand provides a simple accompaniment. A circled '1' is placed above the final measure of this system.

Musical notation for measures 9-16. The right hand continues the melodic theme with grace notes. A circled '2' is placed above the second measure of this system.

Musical notation for measures 17-24. The right hand has a more active melodic line with grace notes. A circled '3' is placed above the first measure, and a circled '5' is placed above the fifth measure of this system.

Musical notation for measures 25-32. The right hand features a melodic line with grace notes and slurs. A circled '6' is placed above the first measure, and circled '9' and '6' are placed above the ninth and tenth measures of this system. A circled '10' is placed above the first measure of the final system, which includes a circled '5' above the last measure.

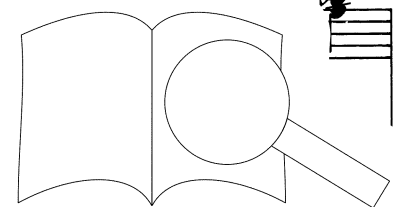

PROBEN
Ausgabequalität gegenüber Original evtl. gemindert • Evaluation Copy - Quality may be reduced • Carus-Verlag

33

1

41

5

49

57

65

12 Lentement

13

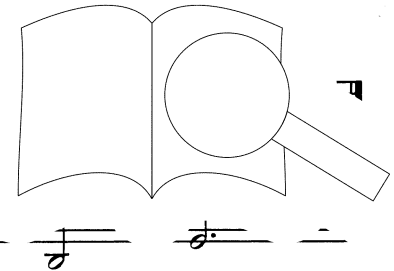

PROBEPARTITUR

Ausgabequalität gegenüber Original evtl. gemindert • Evaluation Copy - Quality may be reduced • Carus-Verlag

4. Basse de Cromorne

Gay

Jeu doux

Basse

Detailed description: This block contains the first seven measures of the piece. It is written for a single staff in 2/4 time with a key signature of one flat (Bb). The tempo/mood is 'Gay' and the performance instruction is 'Jeu doux'. The notation includes eighth and sixteenth notes in the right hand and rests in the left hand. Measure 7 ends with a repeat sign.

8

Detailed description: This block contains measures 8 through 14. The right hand features chords and eighth notes, while the left hand has a steady eighth-note accompaniment. Measure 14 ends with a repeat sign.

15

Detailed description: This block contains measures 15 through 21. The right hand has chords and quarter notes, while the left hand continues with eighth notes. Measure 21 ends with a repeat sign.

22

Detailed description: This block contains measures 22 through 33. The right hand has chords and quarter notes, while the left hand has eighth notes. Measure 33 ends with a repeat sign.

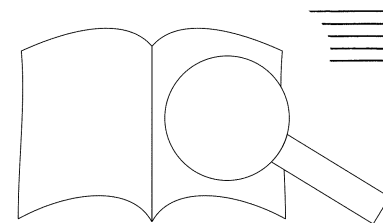

29

36

43

50

5. Flûtes

Récit de flûtes au grand clavier

Flûtes au positif

Flûtes au grand clavier

Flûtes au grand clavier

13

Positif

Récit

36

20

Trio

Grand Clavier

26

Récit

Positif

32

38

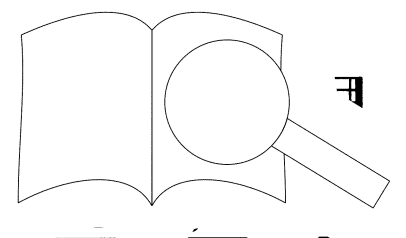

6. Récit de Nazard

Gayement et gracieusement ①

Nazard

Musical notation for measures 1-5. The piece is in 12/8 time and B-flat major. The right hand features a melodic line with grace notes and slurs, while the left hand provides a harmonic accompaniment. A circled '1' is placed above the first measure. The instruction 'Jeu doux' is written below the first measure.

Musical notation for measures 6-10. The right hand continues the melodic pattern with grace notes. The left hand accompaniment remains consistent. A circled '2' is placed above the sixth measure. The instruction 'Nazard' is written above the tenth measure.

Musical notation for measures 11-15. The right hand continues the melodic pattern. The left hand accompaniment remains consistent.

Musical notation for measures 16-37. The right hand continues the melodic pattern. The left hand accompaniment remains consistent. The instruction 'Nazard' is written above the 17th measure. The piece concludes with a final cadence in the right hand.

PROBE PARTITUR
Ausgabequalität gegenüber Original evtl. gemindert • Evaluation Copy - Quality may be reduced • Carus-Verlag

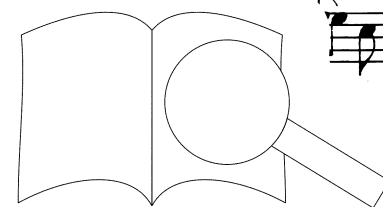

21

3

4

25

29

5

Jeu doux

33

37

Lentement

6

7

8

9

10

Ped.

7. Caprice sur les grands jeux

Gayement

Musical notation for measures 1-5. The piece is in 3/4 time with a key signature of one flat (B-flat). The melody is in the right hand, featuring eighth and sixteenth notes with some trills. The left hand has a simple accompaniment of quarter notes.

Musical notation for measures 6-10. The melody continues with more complex rhythmic patterns, including sixteenth notes and trills. The left hand accompaniment remains consistent.

Musical notation for measures 11-15. The piece features a key change to two sharps (D major) starting at measure 11. The melody is more active with frequent sixteenth notes.

Musical notation for measures 16-20. The melody continues in D major. The left hand accompaniment consists of steady eighth notes. The piece concludes with a final cadence.

PROBENPARTITUR

Ausgabequalität gegenüber Original evtl. gemindert • Evaluation Copy - Quality may be reduced • Carus-Verlag

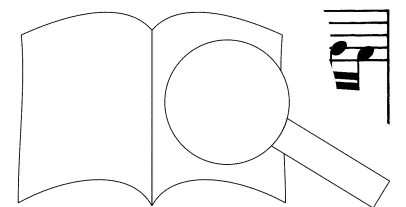

21

25

30

34

39

* N₂ Trompette des Pedals. / Pedal with Trumpet if desired.

Tocatta tertia

1
Allegro

Musical notation for measures 1-3. Measure 1 starts with a treble clef, a common time signature, and a 7-measure rest. The right hand plays a series of eighth notes, while the left hand plays a sustained bass line. Measure 2 continues the eighth-note pattern. Measure 3 features a trill (tw) in the right hand. A circled '1' is above measure 1, and a circled '2' is above measure 3. The word 'Pedal' is written below the first measure.

Musical notation for measures 4-6. Measure 4 has a treble clef and a 4-measure rest. The right hand plays a series of eighth notes, while the left hand plays a sustained bass line. Measure 5 continues the eighth-note pattern. Measure 6 features a trill (tw) in the right hand. A circled '4' is above measure 4, and a circled '5' is above measure 5. The word 'Ped.' is written below measure 6.

Musical notation for measures 7-8. Measure 7 has a treble clef and a 6-measure rest. The right hand plays a series of eighth notes, while the left hand plays a sustained bass line. Measure 8 continues the eighth-note pattern. A circled '7' is above measure 7, and a circled '8' is above measure 8. The word 'Ped.' is written below measure 7.

Musical notation for measures 9-10. Measure 9 has a treble clef and a 9-measure rest. The right hand plays a series of eighth notes, while the left hand plays a sustained bass line. Measure 10 continues the eighth-note pattern. A circled '9' is above measure 9. The word 'Ped.' is written below measure 9.

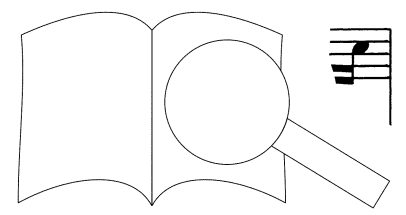

PROBEPARTITUR
Evaluation Copy - Quality may be reduced • Carus-Verlag

Muffat
94

13

Musical notation for measures 13-16. The system consists of two staves. The right staff contains a melodic line with various ornaments (t) and slurs. The left staff contains a bass line with a 7-measure rest in measure 14.

17

Musical notation for measures 17-20. The system consists of two staves. The right staff contains a melodic line with ornaments (t) and slurs. The left staff contains a bass line with a 7-measure rest in measure 17.

21

Musical notation for measures 21-24. The system consists of two staves. The right staff contains a melodic line with ornaments (t) and slurs. The left staff contains a bass line with a 7-measure rest in measure 21. A circled number 10 is placed above the right staff in measure 24.

25

Musical notation for measures 25-28. The system consists of two staves. The right staff contains a melodic line with ornaments (t) and slurs. The left staff contains a bass line with a 4-measure rest in measure 25. A circled number 4 is placed above the right staff in measure 28.

29

Musical notation for measures 29-32. The system consists of two staves. The right staff contains a melodic line with ornaments (t) and slurs. The left staff contains a bass line with a 10-measure rest in measure 29. A circled number 10 is placed above the right staff in measure 32. A circled number 12 is placed above the right staff in measure 31. The notation includes 'tw' markings in measure 32.

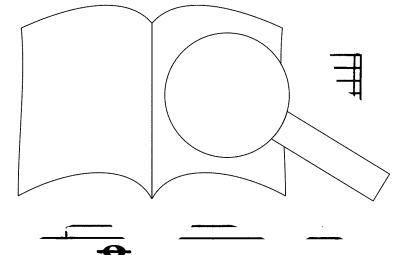

32

13

Musical notation for measures 32-35. The system includes a treble and bass clef. Measure 32 starts with a piano mezzo-forte (P.m.) dynamic. Measure 35 ends with a piano sostenuto (P.s.) dynamic. The music features a complex rhythmic pattern with many sixteenth notes.

36

11

Musical notation for measures 36-39. The system includes a treble and bass clef. Measure 36 starts with a piano mezzo-forte (P.m.) dynamic. The music continues with the same complex rhythmic pattern.

40

14

Adagio

Musical notation for measures 40-43. The system includes a treble and bass clef. Measure 40 starts with a first ending bracket. The tempo is marked Adagio. The music features a first ending bracket and a fermata over a measure.

44

Musical notation for measures 44-46. The system includes a treble and bass clef. The music continues with the same complex rhythmic pattern.

47

Musical notation for measures 47-50. The system includes a treble and bass clef. Measure 47 starts with a piano mezzo-forte (P.m.) dynamic. The music concludes with a final cadence.

44

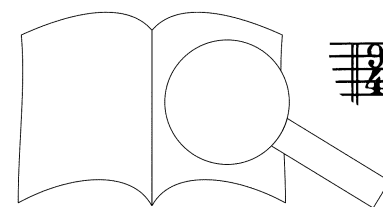

51 17

55

59

63 18

67

PROBEPARTITUR
Ausgabequalität gegenüber Original evtl. gemindert • Evaluation Copy - Quality may be reduced • Carus-Verlag

70

Musical notation for measures 70-72. The right hand features a melodic line with a trill (t) in measure 70. The left hand has a steady eighth-note accompaniment.

73

Musical notation for measures 73-75. The right hand continues the melodic line with a trill (t) in measure 74. The left hand accompaniment remains consistent.

76

Musical notation for measures 76-78. The right hand has a trill (t) in measure 76. The left hand accompaniment continues.

79

Musical notation for measures 79-81. The right hand has a trill (t) in measure 79. The left hand accompaniment continues.

82

Musical notation for measures 82-84. The tempo is marked **Adagio**. Measures 20, 21, 22, and 23 are circled. The right hand has trills (tw) in measures 21, 22, and 23. The left hand has a steady accompaniment. A **P.m.** (Pédale manuelle) marking is present at the end of measure 82. A **Pedale continuo tenet** instruction is also visible.

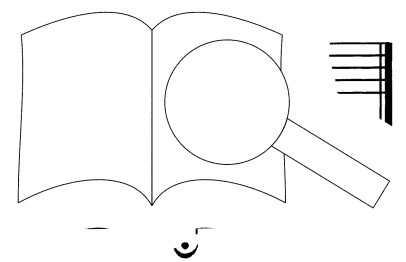

PROBEEPARTITUR
 Ausgabequalität gegenüber Original evtl. gemindert • Evaluation Copy - Quality may be reduced • Carus-Verlag

Tres glosas

sobre el canto llano de la
Immaculada Concepcion

Francisco Correo 1584-1657

1 2

To - do el mū - do è ge - ne - ral a vo - zes Re - dē - ai - gan

10 1 3

q̇ Soys con - ce - vi - da sin pe - ca - do o - ri - gi - nal.

21 Copla segunda 2 4 5

Si man - ro

30 2

PROBEN
Ausgabequalität gegenüber Original evtl. gemindert • Evaluation Copy - Quality may be reduced • Carus-Verlag

38

Musical notation for measures 38-45, featuring a treble and bass staff with various notes and rests.

46

Musical notation for measures 46-56, featuring a treble and bass staff with various notes and rests.

Otra copla glosada de nueve al compás

57

Musical notation for measures 57-62, featuring a treble and bass staff with various notes and rests. Includes a circled '6' above measure 60 and fingerings '2' and '3'.

63

Musical notation for measures 63-69, featuring a treble and bass staff with various notes and rests. Includes a '2' above measure 63.

70

Musical notation for measures 70-77, featuring a treble and bass staff with various notes and rests. Includes fingerings '2' and '3' above measures 72 and 74 respectively.

48

PROBENPARTITUR
 Ausgabequalität gegenüber Original evtl. gemindert • Evaluation Copy - Quality may be reduced • Carus-Verlag

76

Musical notation for measures 76-81. The system consists of a treble clef staff and a bass clef staff. The treble staff contains a melodic line with eighth and sixteenth notes, and some rests. The bass staff contains a harmonic accompaniment with chords and moving lines. A fermata is placed over the final note of measure 81. A '2' is written above the final measure.

82

Musical notation for measures 82-88. The system consists of a treble clef staff and a bass clef staff. The treble staff contains a melodic line with eighth and sixteenth notes. The bass staff contains a harmonic accompaniment. A '3' is written above the first measure, and a '2' is written above the final measure.

Tercera copla glosada de a doze al compás

89

Musical notation for measures 89-94. The system consists of a treble clef staff and a bass clef staff. The treble staff contains a melodic line with eighth and sixteenth notes. The bass staff contains a harmonic accompaniment. A '2' is written above the first measure.

95

Musical notation for measures 95-101. The system consists of a treble clef staff and a bass clef staff. The treble staff contains a melodic line with eighth and sixteenth notes. The bass staff contains a harmonic accompaniment.

102

Musical notation for measures 102-108. The system consists of a treble clef staff and a bass clef staff. The treble staff contains a melodic line with eighth and sixteenth notes. The bass staff contains a harmonic accompaniment.

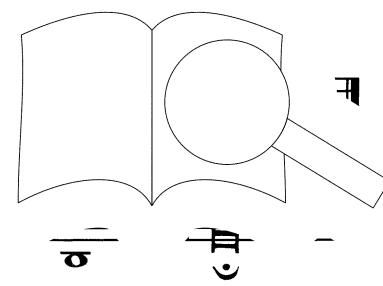

PROBEPARTITUR
 Original evtl. gemindert • Evaluation Copy - Quality may be reduced • Carus-Verlag

Tiento

de medio registro de dos tiples de segundo tono

Francisco Cauxo
1584-1

1 2

10 3 4

18 5 C

22 6

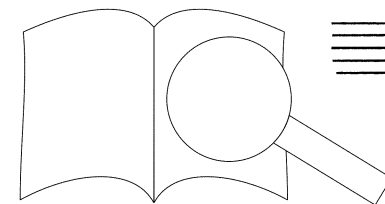

27

8

6

34

7

R

5

39

c

43

6

47

7

R

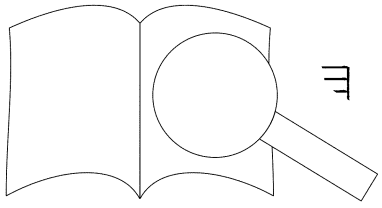

PROBEPARTITUR
 Ausgabequalität gegenüber Original evtl. gemindert • Evaluation Copy - Quality may be reduced • Carus-Verlag

53

Musical notation for measures 53-62, featuring a treble and bass clef with various notes and rests.

63

Musical notation for measures 63-66, featuring a treble and bass clef with various notes and rests.

67

Musical notation for measures 67-70, featuring a treble and bass clef with various notes and rests.

71

Musical notation for measures 71-76, featuring a treble and bass clef with various notes and rests. Includes a circled '7' above measure 71 and a circled '11' above measure 76.

77

Musical notation for measures 77-82, featuring a treble and bass clef with various notes and rests. Includes a circled '7' above measure 77, a circled '6' above measure 80, and a circled '11' above measure 82.

52

10

R

10

R

11

R

11

R

PROBEPARTITUR

Ausgabequalität gegenüber Original evtl. gemindert • Evaluation Copy - Quality may be reduced • Carus-Verlag

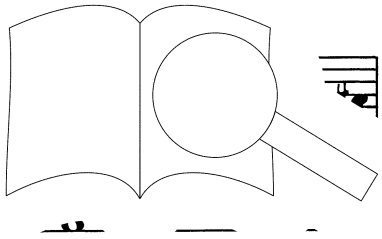

84

10 R

6

6

3

5

90

95

C

99

103

7 R

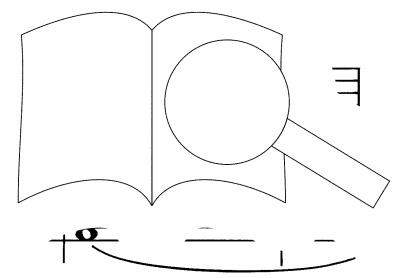

PROBEPARTITUR

Evaluation Copy - Quality may be reduced • Carus-Verlag

Ausgabequalität gegenüber Original evtl. gemindert •

108

6

113

12

116

13

119

122

11

R

PROBEPARTITUR
 Ausgabequalität gegenüber Original evtl. gemindert • Evaluation Copy - Quality may be reduced • Carus-Verlag

Voluntary for Double Organ

1 2 3 4

Chair Organ

7

13

Great Orr

18

Chair Organ

The musical score is written for a double organ, consisting of two staves: the upper staff for the Chair Organ and the lower staff for the Great Organ. The piece is in 4/4 time and begins with a key signature of one flat (B-flat). The score is divided into four measures, numbered 1 through 4. Measure 1 contains a whole rest for both parts. Measure 2 begins with a series of eighth notes in the Chair Organ part, while the Great Organ part has a whole rest. Measure 3 continues the eighth-note pattern in the Chair Organ. Measure 4 concludes with a final chord. The score includes various musical notations such as slurs, ties, and dynamic markings. A large watermark 'PROBEPARTITUR' is overlaid diagonally across the page, along with the text 'Evaluation Copy - Quality may be reduced • Carus-Verlag'. A small icon of an open book with a magnifying glass is located in the bottom right corner.

22

Great Organ

6

Musical notation for measures 22-25, featuring a treble and bass clef with various notes and rests. The piece is in a key with one flat (B-flat major or D minor).

26

Musical notation for measures 26-27, continuing the piece with similar rhythmic patterns.

28

Chare Organ

Musical notation for measures 28-33, including a section labeled 'Chare Organ' and a 'rit.' (ritardando) marking.

34

Musical notation for measures 34-35, showing a change in texture and dynamics.

36

Musical notation for measures 36-55, including a section with a 'rit.' marking and a large graphic of an open book at the end of the system.

56

PROBEPARTITUR

Ausgabequalität gegenüber Original evtl. gemindert • Evaluation Copy - Quality may be reduced • Carus-Verlag

42

45

Chire Organ

Great Organ

7

50

Great Organ

54

little Organ

58

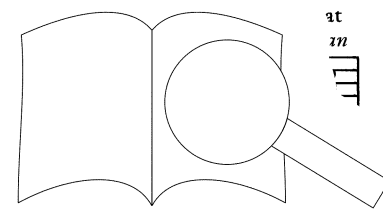

at
in

62

little Organ

65

Great Organ both hands

69

73

77

58

PROBEPARTITUR
 Ausgabequalität gegenüber Original evtl. gemindert • Evaluation Copy - Quality may be reduced • Carus-Verlag

O Mensch, beweine deine Sünde groß

à 2 Clav. et Ped.
BWV 622

Adagio assai

1 a. b.

2 tr

3 tr

4 tr

5 tr

8

9 tr

10

7

11 12 5 13 13

10

2 1 7 1

13

16 13

PROBEPARTITUR

Ausgabequalität gegenüber Original evtl. gemindert • Evaluation Copy - Quality may be reduced • Carus-Verlag

16

1 17 18 19 1

20

19

5

21

22

22 adagissimo 23

7

Fond d'orgue

I. Hand

①

9 ②

17 ③

26

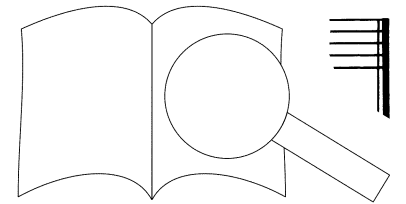

PROBEPARTITUR
Evaluation Copy - Quality may be reduced • Carus-Verlag

Ausgabequalität gegenüber Original evtl. gemindert •

Sonata in g

H 87/Wq 70,6

Carl Philipp Bach
1714–1783

I. Allegro moderato

1. **f** 2. **p** 3. **f** 4. **p** 5. **f** 6. **p** 7. **f** 8. **p** 9. **f** 10. **p** 11. **f** 12. **p** 13. **f** 14. **p** 15. **f** 16. **p** 17. **f** 18. **p** 19. **f** 20. **p** 21. **f** 22. **p** 23. **f** 24. **p**

27

Musical notation for measures 27-32. The system consists of a treble and bass clef. Measure 27 starts with a repeat sign. Measure 32 has a circled '12' above it. The music features a mix of eighth and sixteenth notes with various articulations.

33

Musical notation for measures 33-39. Measure 33 has a circled '13' above it. Dynamics include piano (p) and forte (f). Measure 39 has a circled '4' above it. The bass line features a steady eighth-note accompaniment.

40

Musical notation for measures 40-44. Measure 40 has a circled '13' above it. Dynamics include forte (f) and piano (p). Measure 44 has a circled '1' above it. The right hand features triplet patterns in measures 42-44.

45

Musical notation for measures 45-51. Measure 45 has a circled '6' above it. Dynamics include forte (f) and piano (p). Measure 51 has a circled '1' above it. The music includes triplet patterns in the right hand.

64

Musical notation for measures 64-70. Measure 64 has a circled '12' above it. Measure 70 has a circled '12' above it. The system concludes with a double bar line and repeat sign.

PROBEPARTITUR

Ausgabequalität gegenüber Original evtl. gemindert • Evaluation Copy - Quality may be reduced • Carus-Verlag

57

57-63

p *f*

This system contains measures 57 through 63. The music is written for piano in a 4/4 time signature with a key signature of one flat (B-flat major). The right hand features a complex melodic line with many beamed eighth and sixteenth notes, while the left hand provides a steady accompaniment of eighth notes. Dynamic markings include piano (*p*) and forte (*f*).

64

64-69

p *f*

This system contains measures 64 through 69. The right hand continues with intricate melodic patterns, and the left hand maintains a consistent eighth-note accompaniment. Dynamic markings include piano (*p*) and forte (*f*).

70

70-72

3

This system contains measures 70 through 72. Measure 70 features a triplet of eighth notes in the right hand. The left hand continues with eighth-note accompaniment. The system concludes with a double bar line.

73

73-76

This system contains measures 73 through 76. The right hand has a melodic line with some grace notes, and the left hand continues with eighth-note accompaniment. The system concludes with a double bar line.

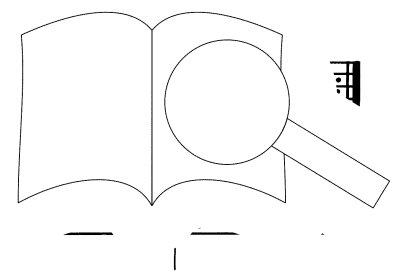

2. Adagio

Musical notation for measures 1-4. The score is in G major (one sharp) and common time (C). Measure 1 starts with a circled '1' above the first note. Measure 2 has a circled '2' above the first note. Measure 3 has a circled '3' above the first note. Measure 4 has a circled '4' above the first note. The notation includes treble and bass staves with various note values and rests.

Musical notation for measures 5-8. Measure 5 starts with a circled '3' above the first note. The notation includes treble and bass staves with various note values and rests.

Musical notation for measures 9-12. Measure 9 starts with a circled '3' above the first note. The notation includes treble and bass staves with various note values and rests.

Musical notation for measures 13-16. Measure 13 starts with a circled '3' above the first note. The notation includes treble and bass staves with various note values and rests.

17

7/8

2 3 3

21

5/8

5 6

25

28

p

7

5

3. Allegro

1

2

10

3

17

4

24

PROBEPARTITUR

Ausgabequalität gegenüber Original evtl. gemindert • Evaluation Copy - Quality may be reduced • Carus-Verlag

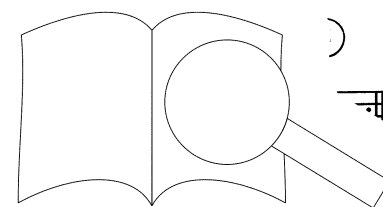

41

Musical score for measures 41-47. The piece is in 7/8 time and B-flat major. The right hand features a melodic line with grace notes and slurs, while the left hand provides a steady accompaniment of eighth notes.

48

Musical score for measures 48-54. The right hand continues the melodic development with slurs and grace notes. The left hand accompaniment remains consistent.

55

Musical score for measures 55-60. The right hand has a dynamic marking of *f* (forte). The left hand accompaniment continues with eighth notes.

61

Musical score for measures 61-67. The right hand features a melodic line with slurs and grace notes. The left hand accompaniment continues.

68

Musical score for measures 68-74. The right hand has a dynamic marking of *pp* (pianissimo). The left hand accompaniment continues.

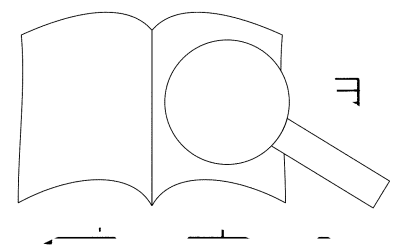

76

Musical notation for measures 76-81. The system consists of a grand staff with a treble clef on the upper staff and a bass clef on the lower staff. The key signature has one flat (B-flat). Measure 76 starts with a treble clef and a 7/8 time signature. The music features a complex rhythmic pattern with many eighth and sixteenth notes in the treble, and a bass line with quarter and eighth notes. There are some ties and slurs across measures.

82

Musical notation for measures 82-86. The system consists of a grand staff with a treble clef on the upper staff and a bass clef on the lower staff. The key signature has one flat (B-flat). Measure 82 starts with a treble clef and a 7/8 time signature. The music continues with similar rhythmic patterns as the previous system, with a focus on eighth and sixteenth notes in the treble.

87

Musical notation for measures 87-90. The system consists of a grand staff with a treble clef on the upper staff and a bass clef on the lower staff. The key signature has one flat (B-flat). Measure 87 starts with a treble clef and a 7/8 time signature. The music continues with similar rhythmic patterns as the previous systems.

91

Musical notation for measures 91-95. The system consists of a grand staff with a treble clef on the upper staff and a bass clef on the lower staff. The key signature has one flat (B-flat). Measure 91 starts with a treble clef and a 7/8 time signature. The music continues with similar rhythmic patterns as the previous systems. There are some slurs and ties in the treble staff.

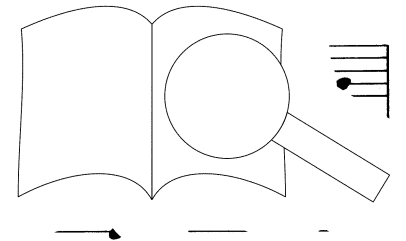

96

Musical score for measures 96-102. The piece is in B-flat major (two flats) and 4/4 time. The right hand features a melodic line with eighth and sixteenth notes, while the left hand provides a rhythmic accompaniment with eighth notes and rests.

103

Musical score for measures 103-110. Measure 103 begins with a forte (*f*) dynamic. The right hand continues with a melodic line, and the left hand has a bass line with some rests. A piano (*p*) dynamic is indicated in measure 105.

111

Musical score for measures 111-118. The right hand has a melodic line with some slurs, and the left hand has a bass line with chords and eighth notes.

119

Musical score for measures 119-126. The right hand has a melodic line with slurs, and the left hand has a bass line with chords and eighth notes.

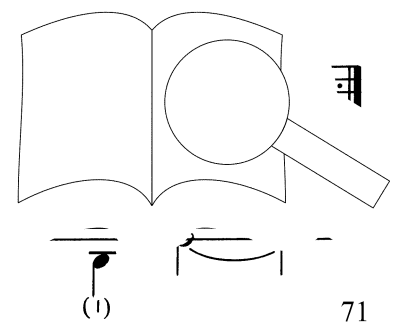

Kritischer Bericht

Zur Edition

Im Notentext sind Ergänzungen des Herausgebers folgendermaßen gekennzeichnet: ergänzte Bögen sind gepunktet, alle Angaben in Buchstaben (*t*- bzw. *tr*-Verzierungszeichen, dynamische Zeichen, Vortrags- und Tempoangaben) stehen kursiv. Pausen sind nur ergänzt, wenn unerlässlich, vornehmlich in polyphonen Sätzen. Sie erscheinen in Kleinstich wie auch zusätzliche Akzidentien („Warnungsakzidentien“) des Herausgebers. Akzidentien gelten für den ganzen Takt, Ausnahmen hiervon bilden die Stücke von Bull, Buchner, Correa de Arauxo und Frescobaldi, denn infolge des damaligen „Schwebezustands“ zwischen modaler und sich erst allmählich festigender Dur-Molltonalität würde eine taktweise Akzidentiensetzung wesentliche Eigenschaften der Werke verdecken. Zusätzliche Verzierungszeichen sind entweder kleingedruckt oder stehen in Klammern. Die Balkensetzung folgt in der Regel der Vorlage, da sie Hinweise zur Ausführung (Artikulation, Interpunktion) geben kann. Taktstriche sind nach heutigen Gepflogenheiten gesetzt, auch wenn sie in der Quelle fehlen. Die Takt- bzw. Satzählung stammt vom Herausgeber.

Ausnahmen von den oben genannten Grundregeln sind Sonderfälle werden von Fall zu Fall mitgeteilt. Die umkreisten Ziffern im Notentext geben im Textband. Die Ausführungs-Ornamenten dürften auch sein. Die Reihenfolge d vom Textband; um ur den, wurde d Seite 62 Angal

System (I be-
Zeichen im Takt
/ Bemerkung.

John Bull (?): A prelude

Quelle: Royal College of Music, London (GB-Lcm)
Sign.: R. C. M. 2093, f. 3^v-4^r

Die nicht datierbare Quelle ist auf zwei Systemen mit je 6 Linien notiert. Sie enthält zwei Sammlungen von größtenteils mit Fingersatz versehener Tastenmusik meist anonymen Meister; der Schreiber ist nicht bekannt. Das vorliegende Stück, das dritte der ersten Sammlung, hat keine Komponistenangabe; in anderen Quellen ist aber John Bull als Autor ausgewiesen. Die Finger der linken Hand sind folgendermaßen bezeichnet: der Daumen mit 5, der Zeigefinger mit 4 usw. (Vgl. das Faksimile auf S. V.)

Johannes Buchner: Quem terra pontus

Quelle: *Fundamentum, sive ratio vera, quae de planum, sive (ut vocant) choraliter versarum vocum symphonias*
Öffentliche Bibliothek der Universität
Sign.: Hs. F 1 8a, S. 9

Vollständiger Titel: *Quem terra*

Die 1551 in älterer
le im Textband
denen *Fun*.
Die Fingersatz
halten.

er-Bi
im Friedemann Bach
cke Rare Book & Manuscript Library,
(US-NH) (Autograph)

oberen System Sopranschlüssel, im unteren
gl. das Faksimile auf S. VI.)

Johan Pieterszoon Sweelinck: Ballo del granduca

Quelle: Nationalmuseum Széchenyi, Budapest (H-Bn)
Sign.: Ms. mus. Bártfa 27, f. 35^v-37^r

Originaltitel: *Balleth. del granduca. M. Joan: Pet: S: Amb: Org:*

Die Quelle stammt aus der zweiten Hälfte des 17. Jahrhunderts; der Schreiber ist unbekannt. Originalnotation: neuere deutsche Tabulatur. Die Fingersätze sowie die Takte 20a, 40b, 44a, 60b, 64a, 80b und 100b sind vom Herausgeber.

Einzelanmerkungen:

5 II: *d'* statt *h*
13 II 1-4: 4tel *A-B-c-d*
13 II: Ganze *cis'* statt *c'*
16f I: kein Haltebogen
31 II: *g* statt *gis*
35 I 11-12: *fis'-g'*
45 I 2: mit 4tel *d'*
46 I: Halbe *a' s+*
53 I: *cis' st-*
54 I: *C*
6^v

ch: *g*
reußischer Kulturbesitz,
ndelssohn-Archiv (D-B)
omposée par J. S. Bach

an Caspar Vogler, einem Schüler J. S. Bachs, zwischen
1731 geschriebene Quelle enthält neben BWV 870a Ab-
ritten von BWV 899; 900; 901; 527,1; 875,1 und 902. Die Finger-
sätze sind original. Schlüsselvorsatz: im oberen System Sopranschlüs-
sel, im unteren Baßschlüssel.

Einzelanmerkung:
3 II: Halbe *c* statt 4tel

Johann Sebastian Bach: Praeludium in c (BWV 847)

Quelle: *Clavier-Büchlein vor Wilhelm Friedemann Bach*
Yale University, Beinecke Rare Book & Manuscript Library,
New Haven, USA (US-NH) (Autograph)

Es handelt sich hier um eine frühe Version des Präludiums in c (ebenfalls BWV 847) aus dem ersten Teil des *Wohltemperierten Claviers*. Schlüsselvorsatz: im oberen System Sopranschlüssel, im unteren Baßschlüssel.

Girolamo Frescobaldi: To

Quelle: *Toccate d'intav
diverse arie e cc*
Rom 1637 (1. T
Bayerische Staa
Sign.: 2 Mus. pi

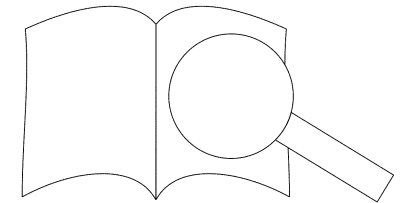

Das erste Toccatenbuch Frescobaldis wurde erstmals 1615 in Rom bei Nicolò Borboni verlegt und erschien zu Lebzeiten des Komponisten in drei weiteren veränderten und vermehrten Auflagen (1616, 1628 und 1637), ebenfalls bei Nicolò Borboni. Die Notationsweise des schönen Druckes – in italienischer Tabulatur mit zwei Systemen, sechs Zeilen im oberen bzw. acht Zeilen im unteren System (s. Faksimile im Textband, Teil B, Kap. I.1.) – wurde hinsichtlich der Einzelhaltung von Halbenoten und 4teln im akkordischen Satzbild, der Balkung der 8tel etc. originaltreu übernommen. Alle Vortragsangaben sind vom Herausgeber.

Einzelmerkungen:
 19 I: übergebundenes *g'* 16tel statt 8tel
 25 I 24: 16tel *fis'* statt 8tel
 28 II: *a* und *g* 16tel statt 32stel

Louis-Nicolas Clérambault: Premier Livre d'Orgue

Quelle: Bibliothèque Nationale, Paris (F-Pn)
 Sign.: Vm7 1832

Der Erstdruck des *Premier Livre* Clérambaults erschien 1710 in Paris chez L'Auteur („beim Autor“), wie auf dem Titelblatt vermerkt. Dem Druck vorangestellt ist eine huldigende Dedikation an Clérambaults Lehrer André Raison. Auf der letzten Seite nach der Druckerlaubnis des Königs steht folgendes *avertissement*:

J'ai composé ces pieces de maniere qu'on peut les jouer aussi facilement sur un cabinet d'orgue a jeux coupés, que sur un grand Orgue, c'est pourquoi dans la Basse de trompette, et dans les recits, les accompagnements des jeux doux ne passent pas le milieu du Clavier, non plus que les sujets du Dessus de la Basse. Ceux qui ont de grands Orgues pourront mettre les accompagnements de la main gauche à l'octave en haut s'ils les trouvent
 („Ich habe diese Stücke so komponiert, daß man sie ebenso auf einer Kammerorgel mit geteilten Registern wie auf einer großen Orgel spielen kann. Deswegen überschreiten weder die *jeux-doux* der linken Hand die Mitte der Tastatur und in den *Récits* noch die *jeux-doux* der rechten Hand die Mitte der Tastatur. Diejenigen, welche größere Orgeln besitzen, können die Begleitstimmen der linken Hand höher nehmen, sollten sie finden“)

Fehlende *accents* in den Originaltexten wurden entsprechend der Schreibweise übernommen.

Einige Vorzeichen sind in der Ausgabe vorausgehenden Takten vorangestellt.

6. Récits de Cromorne, et de Cornet séparé, en Dialogue

43ff: auf zwei Systemen notiert
 47 II 1: *f'* Triller statt Mordent

7. Dialogue sur les grands jeux

... *qui sont doux* („die leise sind“) ist in der Quelle handschriftlich zu *qui sont à 2* („die zweistimmig sind“) geändert worden.

Suite du deuxième ton (vgl. Faksimile auf S. 75)

4. Basse de Cromorne

8 II 2–7: 8tel zusammengebalkt

6. Récit de Nazard

11 II 5: *des* statt *d*

Georg Muffat: Toccata tertia

Quelle: *Apparatus musico-organicus*, Gesellschaft der Freunde der Kunst, 1731, S. 3.

Die *Toccatata tertia* Muffats ist in der Quelle handschriftlich als „Original“ bezeichnet. Die *alle* sind in der Ausgabe explizit vorhanden. Die *alle* sind in der Quelle ursprünglich *f'*, später zu *a'* korrigiert. Die *alle* sind ursprünglich *h* statt 4telpause.

Correa de Arauxo: Tres glosas sobre el canto llano de la Catedral de Concepcion

Quelle: *Libro de tintos y discursos de musica practica y theorica de organo, intitulado Facultad organica*, Alcalá 1626, Universiteit Utrecht, Faculteit der Letteren (NL-Uim)
 Sign.: LB-MUZ Bq Correa 1, f. 203^v–204^v

Die *Facultad Correa* ist in spanischer Tabulatur notiert, in der die Tonhöhe mit Zahlen angegeben wird (s. Faksimile im Textband, Teil B, Kap. I.5.). Die in der Quelle über dem Notensystem stehenden Zahlen 2 und 3, welche die Einteilung der (kleineren) Notenwerte in duolische bzw. triolische Gruppen anzeigen, sind im Original nicht immer richtig bzw. sinn-

voll plaziert, sondern erscheinen normalerweise jeweils am Anfang. Dies wurde hier entsprechend korrigiert. Nach dem Titel folgt ein längerer Text, in dem es heißt: *el flautado a los contrabajos, y a los tiradores fuere al organista* („man kann den Flauto und die Mixtur für die Oberstimmen verwenden“).

Einzelmerkungen:
 7 II 2: *B* statt *c*
 9 II 3: *F* statt *f*
 37 II 7: 87

Henry Percell: Voluntary for Double Organ

Quelle: British Library, London (GB-Lbm)
 Sign.: Add. MS 31468, f. 24^v–27^v
 Originaltitel: *A Volantary for ye Duble Organ By Mr Henry Percell*

Der auf f. 49^v der Quelle eingetragene Vermerk *Will Davis/Eius liber* weist den von 1721 bis 1745 als Master of Chorister (Leiter des Knabenchores) an der Kathedrale zu Worcester tätigen Will Davis als Schreiber oder zumindest als Besitzer aus. Die Quelle enthält außerdem noch Werke u. a. von Chr. Gibbons, J. Blow, W. Croft sowie von Davis selbst. Im Original auf zwei Systemen mit je 6 Zeilen notiert. Die unterschiedliche Bezeichnung der Manuale wurde übernommen.

Einzelmerkungen:
 1: Ein der 8telpause ähnliches Zeichen steht über dem oberen System
 2 II: // steht über *cis'* und nicht über *d'*
 9 I 4: // auf *h'* statt auf *c'*
 10 I 1–3: *e'* mit undeutlichen *h'*
 14ff: die Halben und 4tel r sind zusammen, teils ein- und teils zwei-
 19 II 5–8: wegen Schlußstrich die 16tel *a-cis'* bzw. *a-cis'*
 27 II: linke Hand in der Q

33 II 11, 12: *a-c'* statt *c'*

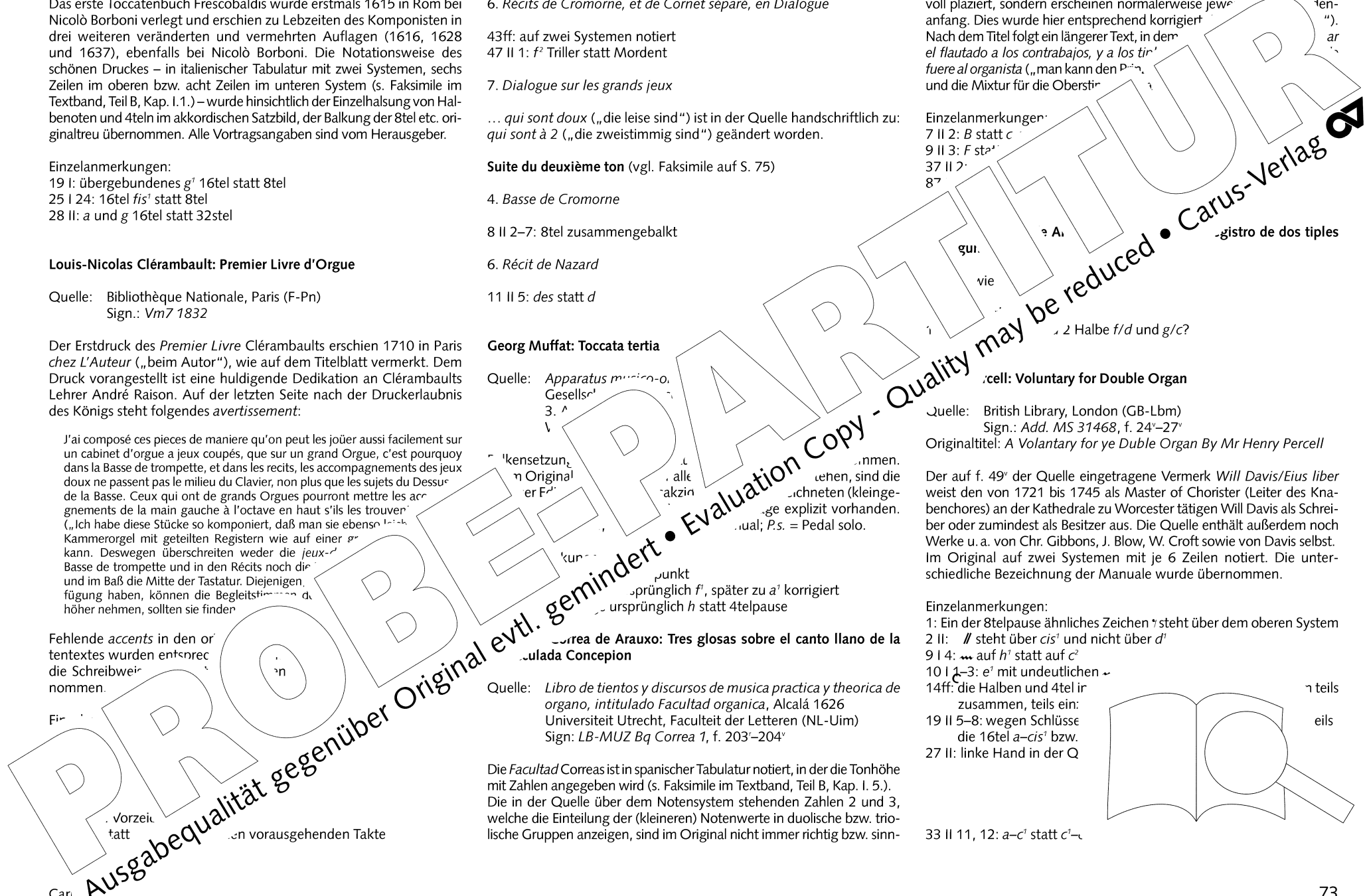
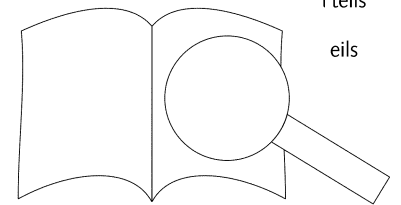

- 34 II 27: *cis* statt *c*
- 35 I 1–2: 4telpause statt *f*¹, Terz *f*¹/*d*¹ statt *d*¹
- 37 I 6: *h*¹ ursprünglich Halbe, später eingeschwärzt
- 48 II 1–4: die 8tel sind hier paarweise gebalkt, im weiteren Verlauf auch in Vierergruppen
- 50 I 1: punktierte Halbe *a*¹
- 51 II 3: der den *fore fall* anzeigende Strich ist sehr lang, vielleicht handelt es sich um einen Tintenklecks
- 52: *Single Organ* schon über *E* in T. 51
- 57: *little organ* am Taktfang
- 58 I 1: *ais* statt *a*
- 62: *little or.* über 4tel *c/e* in T. 61
- 65 II 2: *C* ohne Verlängerungspunkt
- 70 I 5: *gis*¹ statt *h*¹
- 75 I 2 bis Ende T. 76: ursprünglich eine Terz zu hoch notiert, noch in der Quelle korrigiert
- 75 I 6–8: originaler Rythmus: □□
- 77 I 2: mit //
- 78 I und II 1–3: originaler Rhythmus □□

Johann Sebastian Bach: O Mensch, bewein dein Sünde groß (BWV 622)

Quelle: *Orgelbüchlein*
Staatsbibliothek zu Berlin – Preußischer Kulturbesitz (D-B),
Musikabteilung mit Mendelssohn-Archiv
Sign.: P 283, S. 28–29

Im Original auf zwei Systemen notiert. Schlüsselvorsatz: im oberen System Sopranschlüssel, im unteren Baßschlüssel.

Einzelanmerkungen:
2 II 6: ursprünglich *des*¹, später in *d* (mit Auflösungszeichen)

Louis Marchand: Fond d'orgue

Quelle: *Deuxième Livre d'Orgue*
Bibliothèque municipale
Sign.: MS 61/1, f
(wahrscheinlich *e*)

Das querfr
ist das
Fr

ats.
Musika
Sign
Preußischer Kulturbesitz (D-B),
Mendelssohn-Archiv
Sign.: B: P 366, S. 10–19; C: P 434, S. 13–19

Grundlage unserer Edition ist die aus der zweiten Hälfte des 18. Jahrhunderts stammende Abschrift P 764 eines unbekanntenen Schreibers (A). Die Quellen B und C wurden zum Vergleich herangezogen. Aus ihnen wurden z. B. einige Legatobögen übernommen. Der 1791, also posthum von J. C. Fr. Rellstab (1759– 1813) veröffentlichte Erstdruck der Orgelsonaten Carl Philipp Emanuels hat für eine Neuausgabe wenig Relevanz, da Rellstab bedeutende Eingriffe in den Notentext vornahm, um die Ausführung der Sonaten auf einem Instrument mit damals üblichem Manualumfang bis *c*² zu ermöglichen. Das Titelblatt von A trägt den Vermerk *No 80 Berl. 1755*. Unter dieser Nummer ist die Sonate im vermutlich von Carl Philipp Emanuel selbst vorbereiteten, 1790 posthum in Hamburg erschienenen *Verzeichnis des musikalischen Nachlasses des verstorbenen Capellmeisters Carl Philipp Emanuel Bach* verzeichnet (Faksimile: Garland Publishing Inc., New York/London 1981).

B könnte von Johann Gottfried Mützel (1728–1788) ges sein und enthält Eintragungen (Doppelschläge und Bärer Hand, die, soweit nötig, in den Einzelan sind.

C ist wahrscheinlich die jüngste der drei Absc
Schreiber betitelt den Komponisten
burgo („Kapellmeister in Ham
lipp Emanuel erst im März 1
quem dieser Kopie. Der Schrei
text stark veränd

Einzelanm:

Allegro mo

mit T¹

überen System

stac
Strich
Staccatopunkte statt Strich

nur in B
urschlagsnoten *d*² bzw. *c*²
Bögen von *f*² zu *g*² bzw. von *d*² zu *e*²
I: B Bögen analog zu T. 15

- 21 I 7: A Auflösungszeichen fehlt, vor Zeichen 15 aber
- 22 I 1–2: Bogen nur in B
- 28 I 3: C *es*² statt 4telpause
- 29 I 4–5: Bögen aus C
- 32 I 3–4: A Staccatopunkte statt Striche
- 32 II 1–4: A Staccatopunkte statt Striche
- 36 I 3–5: B *es*²–*c*²–*as*¹ mit Legatobogen
- 40 I: C hat 4tel *g*¹ mit 4tel *h*¹
- 41 I 4: A mit Staccatopunkt statt Strich
- 41 I 6–8: A kein Bogen

- 43 I 5: Strich aus B
- 43 I 6: A mit Staccatopunkt statt Strich
- 43 II 4: A mit Staccatopunkt
- 47 I 2–4 und 6–8: C mit Bogen
- 50 I 1–2: Bögen über *es*¹–*d*¹ aus C
- 51 I 1–2: Bögen über *d*¹–*c*¹ *a*¹
- 51 I 2: Strich aus B
- 52 I 3–4: Bogen aus C
- 53 II 5: C *des*¹
- 58 II 4–6: P
- 61 I 1: 6²
- 62: ?ste.
- 63: Striche
- 64: Bogen aus C
- 65: B mit Staccatopunkt
- 66 I 3–4: Bogen aus B
- 7 II 1–2: Bogen aus C
- 8 I 8–10: A Bogenlänge in der Mittelstimme unsicher, vielleicht nur über *f*²–*es*²
- 11 I 9–10: Bogen aus B
- 17 I 1–2 und 5–6: Bögen aus C
- 20 I 10: A *es*² fehlt, auch keine Pause
- 24 I 12f: Haltebogen aus C
- 27 I 5–6 und 7–8: Bögen aus B
- 30 I 5–6: Haltebogen aus C
- 32 I 2–3: Haltebogen aus C

3. *Allegro*

- 2 I 1: B, C haben *↔*
- 9 I 2: Strich aus B
- 10 II 1–2: Bögen aus B
- 27 I 4–5: B 8tel *c*² und *es*¹ *r*
- 30 I 1–2: Bogen in B und C
- 49 II 1: *#* in B und C
- 54 II 1–2: Bogen über *cis*–*76* I 11: B *e*²
- 94 I 1: B, C haben *↔*
- 96 I 1: B, C haben *↔*
- 105 I 5f: Haltebogen in B

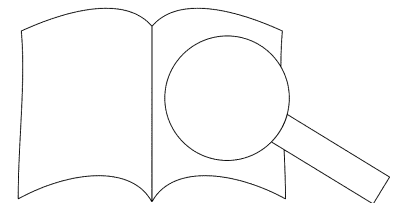

SUITE DU DEUXIEME TON.

Plein jeu.

Petit plein jeu au Positif.

*Grand plein jeu.
Lentement.*

*Gay
Positif.*

PROBE
Ausgabequalität gegenüber Original evtl. gemindert

Clérambault: *Plein jeu* aus *Suite du deuxième ton* (*Premier Livre d'Orgue*, Clérambault, Paris, Sign.: Vm⁷. 1832, S. 16

L.-N. Clérambault: Opening of the *Plein Jeu* from *Suite du deuxième ton* (Paris 1710) Bibliothèque Nationale, Paris, Sign.: Vm⁷. 1832, S. 16

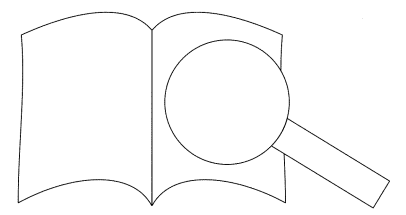

PROBE-PARTITUR
Ausgabequalität gegenüber Original evtl. gemindert • Evaluation Copy - Quality may be reduced • Carus-Verlag

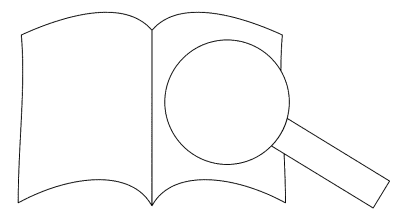

Inhalt/Contents

Einleitung / Introduction / Avant-propos	
John Bull (?)	A preludeium
Johannes Buchner	Quem terra pontus
Johann Sebastian Bach	Applicatio (BWV 994)
Jan Pieterszoon Sweelinck	Ballo del granduca
Johann Sebastian Bach	Praeludium in C
Johann Sebastian Bach	Praeludium
Girolamo Frescobaldi	Toccata
Louis-Nicolas Clérambault	Suite

	1
	2
	16
	18
	20
	22
	24
	26
	28
	30
	32
	34
	36
	38
	40
	42
	47
	50
	55
	59
	62
	63

Louis Marchand	
Francisco Correa de Arauxo	
Henry Purcell	
Johann Sebastian Bach	
Louis Marchand	
Carl Philipp Emanuel Bach	
Kritischer Bericht	

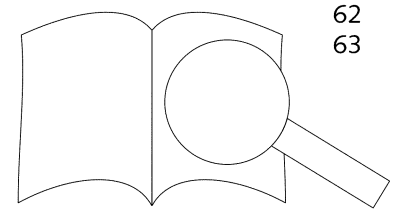

PROBE-PARTITUR
 Original evtl. gemindert • Evaluation Copy - Quality may be reduced • Carus-Verlag

Orgel solo / Organ solo

Bach, J. S.: Fantasia e Fuga in c, BWV 562	40.594/10
- Sonate in C nach BWV 1005 (arr. Bornefeld)	29.177
- Partita in d nach BWV 1004 (arr. Bornefeld)	29.179
Bartók: Suite für Orgel (arr. Bornefeld)	29.174
Beethoven: Adagio cantabile (arr. Gräse)	18.078
Bezler: Biblia Organi. 13 Orgelbilder (Perc ad lib.)	18.069
Bornefeld: Orgelsonate 1965/66	29.105
Cooman: Expressions for organ	18.042
Danziger Orgelmusik des 16.–18. Jahrhunderts	28.003
Das rote Album. Hits for Organ I	18.062
Debussy: Danse (Tarantelle styrienne) (arr. Hirsch)	18.010
Elgar: Enigma Variationen (arr. Hofmann)	18.011
- Vesper Voluntaries	18.008
Freie Orgelmusik der Romantik I, II und III (Völk)	40.591–593
Französische Orgelmusik des 19. Jahrhunderts	91.225
Froberger: Toccaten u. Fantasien	91.075
Fugen des 19. Jahrhunderts (2 Bde)	91.228+91.229
Hindemith: Pastorale, Fuge, Postludium (arr. Bornefeld)	29.152/10
Husumer Orgelbuch (Sammlung, 1758)	18.053
Janca: Manchmal kennen wir Gottes Willen (1992)	18.109
- Kleine Toccata über „Hört, der Engel helle Lieder“ (1995)	18.108
Karkoschka: Toccata und Fuge über 2 Osterchoräle (1953)	18.057
Krebs: Choralbearbeitungen (Erster Teil der Clavier-Übung)	18.524
Mozart, W. A.: Drei Werke für Orgel (KV 594, 608, 616)	18.014
- 17 Kirchengesangsbücher (arr. für Orgel solo)	18.067
Muffat: Apparatus musico-organisticus	91.071
Murschhauser: Octi-Tonium Novum Organicum	91.074
Musik zu Kasualien 4 (für Orgel allein)	2.079
Norddeutsche Orgelmusik 1780–1860 (3 Bde)	18.026/10–30
Ochsenhauser Orgelbuch (1735) (Faksimile und Notenteil)	24.409
Österreichische süddeutsche Orgelmusik (15.–19. Jh.)	92.27
Organo pleno. 140 Stücke zum Ein- und Auszug (17./18. Jh.)	
Orgelbuch Mozart-Haydn (L.+W. A. Mozart, J.+J. M. Haydn)	
Orgelmusik aus Europa (7 Bde)	
Orgelmusik der Familie Hasse (17. Jh.)	
Orgelstücke der Orgelschule Wegweiser (Augs.)	
Orgelwerke der Spätromantik	
Orgelwerke des 16.–18. Jhds (Laukvik)	
Pastorale 1: 47 Pastoralkomp., CH	
Pastorale 2: 64 Pastoralkomp., D	
Peyer: Praembuli e Fughe (2 Bde)	
Praetorius, J.: Drei Pr...	
Puccini: Werke für...	
- Ausgewähl...	
Reger: Säm...	
- W...	
	2.807
	0.238–240, 50.288
	50.264
	18.071
	18.063

Silcher: Sämtliche Orgelstücke	80.121
Vierne: Sämtliche Orgelwerke (13 Bde)	18.150
Alle Werke auch als Einzelausgaben erhältlich	
Vogler: 32 Préludes pour l'Orgue ou Pfte	18.072
Widor: Symphonie II, IV, V, VI, Romane	18.176–180

Vorspiele und Begleitsätze zu Kirchenliedern

Preludes and hymn settings

Aphorismen, Intonationen und Choralvorspiele zum EG (I)	18.115
Aphorismen, Intonationen und Choralvorspiele zum EG (II)	18.116
Bach, J. M.: Sämtliche Orgelchoräle	30.650
Bach, J. S.: Sechs Orgelchoräle nach Kantatensätzen	18.021
- Sechs Choräle à la Schübler (arr. G. Hoffmann)	18.047
- 18 Choralpartiten (Schlenker)	18.117
Bornefeld: Choralpartiten I–VIII	29.064–29.068
- Choralvorspiele I, II	29.027
Brosig: Sämtliche Choralvorspiele	
Choralvorspiele des 19. Jahrhunderts	
Choralvorspiele der Jahrhundertwende (19./20. Jh.)	27
Choralvorspiele zum „Gotteslob“, Bd. 1–4	205
Die Wochenlieder zum EG, 2 Bde	20
Esslinger Orgelbuch. Intonationen, Begleitsätze und Begleitsätze zum EG (3 Bde)	
Freiburger Orgelbuch 1, 2	
Freiburger Kantorenbücher	
Gerok: Kleine Choräle	
Homilius: 32 Choräle	
Horn: 16 Choräle	051
Intonationen	201
Kurze Choräle	18.103
Lehrbuch der Orgel	18.114
Melodieinstrument / organ with 1 melody instrument	
Choralvorspiele (Eh) (arr. Bornefeld)	29.186
Choralvorspiele (Vc) (arr. Bornefeld)	29.193
Bornefeld: Bebuka (Marimbaphon)	29.122
- Choralsonate „Auf, auf, mein Herz“ (Tr)	29.075
- Lituus (Trb)	29.124
- Threni (Eh)	29.123
Busoni: Var. ü. d. Chorallied BWV 517 (VI) (arr. Bornefeld)	29.189
Homilius: Sämtliche Choralvorspiele für Orgel und Melodieinstrumente, Sonate für Ob u. Bc	37.106
Kauffmann: Sechs vierstimmige Choralbearbeitungen (Ob)	13.013
Krebs: Drei Fantasien (Blasinstr.)	13.056
- Freu dich sehr, o meine Seele (Obda)	13.024
- Vier Choralvorspiele (Blasinstr.)	13.055

Langlais: Supplicatio (= 1. Satz der Symph. concertante)	584/50
Mozart: Andante und Fuge in A nach KV 402 (arr. Bornefeld)	9.195
Oley: Wunderbarer König (Ob)	3.023
Purcell: Suite für Trompete und Orgel	21
Raphael: Sonate (Vc)	
Rheinberger: Andante	
- Sechs Stücke für Orgel	
- Suite in c für Orgel	
Romantische Orgelmusik	
Telemann: Orgelmusik (a. d. 1700er Jahre)	187
Widor: Symphonie II, IV, V, VI, Romane	18.176–180

Instrumentalorgelmusik	
Asien	
Organmusik	
Orgelwerke	
Orgelwerke (Ob, VI)	13.070
Orgelwerke (Bornefeld)	29.185
Orgelwerke (Glocke)	29.168
Orgelwerke (Fl)	29.130
Orgelwerke (Original)	11.208+13.014
Orgelwerke (Orgel und 6 Bläser)	26.402
Orgelwerke (Orgel und 8 Bläser (4 Tr, 4 Trb, Timp))	40.586
Orgelwerke (Orgel und 8 Bläser (8 Harm))	13.025
Orgelwerke (Orgel in c (VI, Vc))	50.149

Orgelkonzerte / organ concertos

Anonymous: Concertino a due Cembali (Orgel)	18.504
Bach, J. Chr.: Orgelkonzert in F	38.501
- Orgelkonzert in B	38.502
- Orgelkonzert in Es	38.503
Bach: Konzert in d BWV 1052 (arr. Bornefeld)	29.197
Händel: Concerti d'organo Nr. 7–12	40.538
- Concerti d'organo Nr. 13–16	40.545
- Concerto per la Harpa (Organo)	55.294
Rheinberger: Orgelkonzert Nr. 1 in F op. 137	50.137
- Orgelkonzert Nr. 2 in g op. 177	50.177
Rentzsch: Orgelkonzert (1984)	18.065

Orgelschulen, Bücher / organ instructions, books

Crivellaro: Die Norddeutsche Orgelschule	60.010
Gaar: Orgelimprovisation	24.017
Latry/Mallié: L'œuvre d'orgue d'Olivier Messiaen	24.118
Laukvik: Orgelschule zur historischen Aufführungspraxis	
- Historical Performance Practice	
Teil 1: Barock und Klassik	60.002
Teil 2: Romantik	60.004
Teil 3: Die Moderne	60.006
Part 1: The Baroque and Classical	60.003
Part 2: The Romantic	60.005
Part 3: Modern and Contemporary	60.006
Schildknecht/Schröder:	
Völk: Orgeln in Württemberg	
Wolff/Zepf: Die Orgel	

