

Josef Gabriel
Rheinberger

Sextett op. 191^b

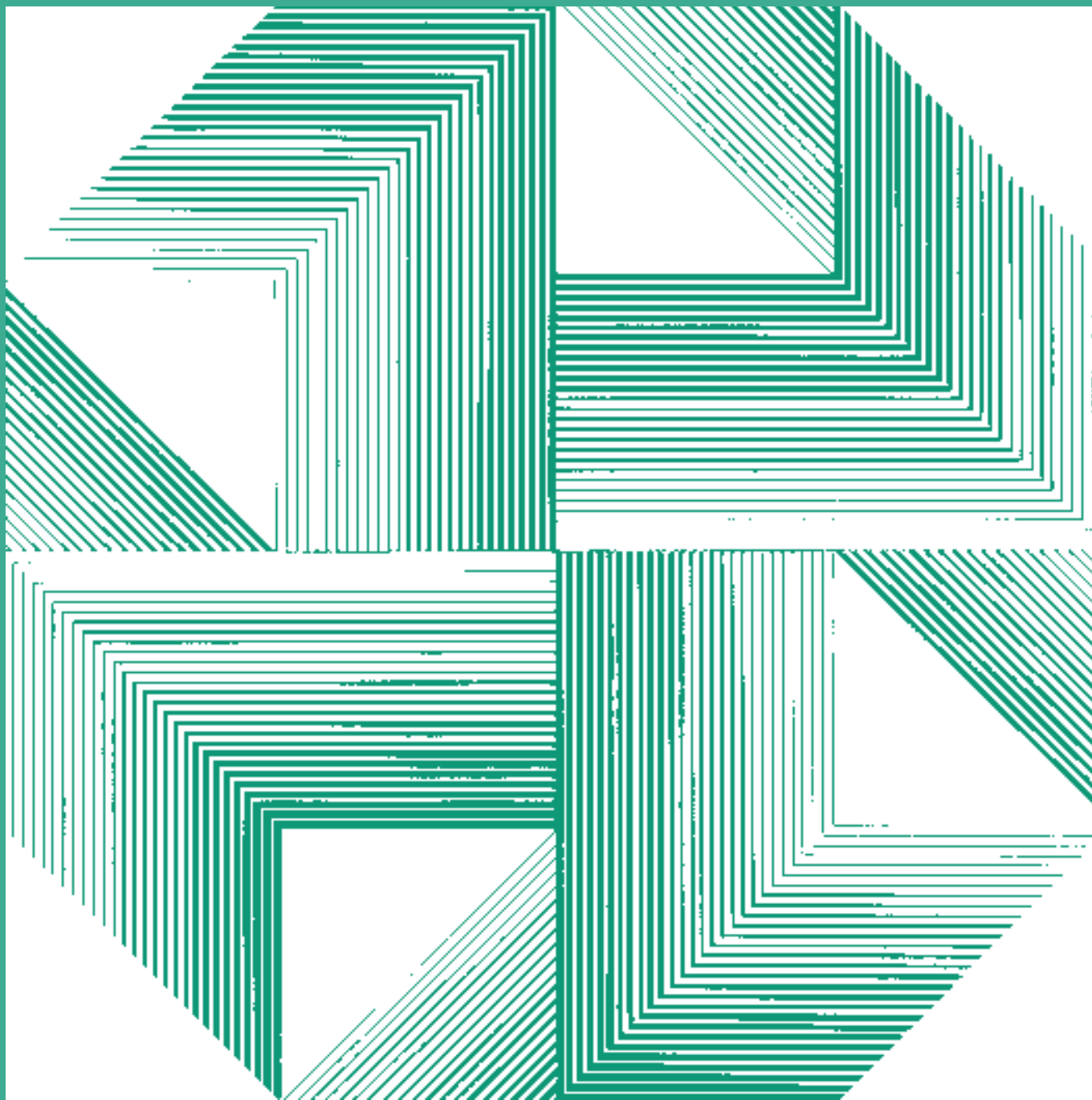

Carus 50.191/60



PROBE-PARTITUR

PROBE-PARTITUR
Ausgabequalität gegenüber Original evtl. gemindert • Evaluation Copy - Quality may be reduced • Carus-Verlag 

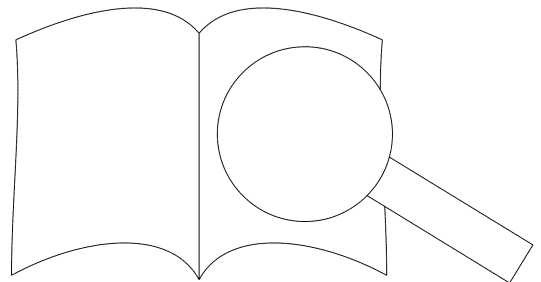

PROBE-PARTITUR

PROBE-PARTITUR
Ausgabequalität gegenüber Original evtl. gemindert • Evaluation Copy - Quality may be reduced • Carus-Verlag 

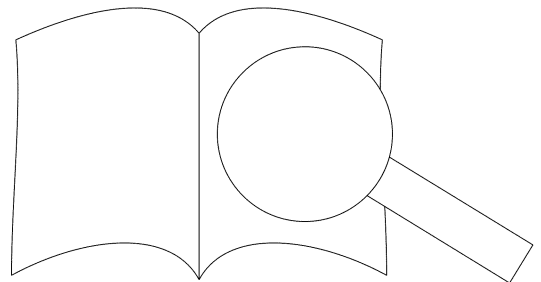

Sextett

I.

Op. 191b (1899)

Moderato ♩ = 96

Flauto

Oboe

Clarinetto in Si \flat /B

Fagotto

Corno in Fa/F

Pianoforte

6 rit. a tea

a tempo

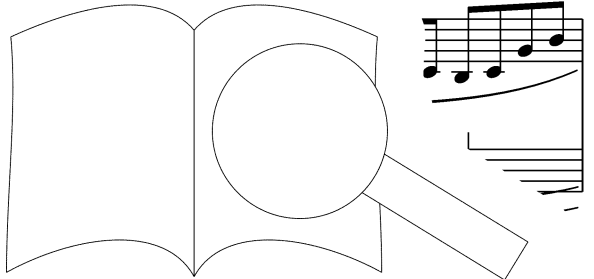

11

Musical score for measures 11-14. The vocal line begins with a melodic phrase. The piano accompaniment features a rhythmic pattern. Dynamics include *cresc.*

15

Musical score for measures 15-19. The vocal line continues with a melodic phrase. The piano accompaniment features a rhythmic pattern. Dynamics include *mf*, *dim.*, and *p*. There are asterisks under some notes.

20

Musical score for measures 20-24. The vocal line includes a section marked **A**. Dynamics include *rit.*, *a tempo*, *p dolce*, and *dim.*. There are asterisks under some notes.

PROBENPARTITUR
 Ausgabegualität gegenüber Original evtl. gemindert • Evaluation Copy - Quality may be reduced • Carus-Verlag

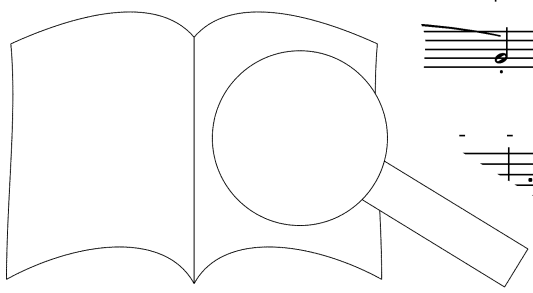

25 a tempo

Musical score for measures 25-28. The score is written for a piano and includes vocal lines. The piano part features a steady eighth-note accompaniment in the left hand and a melodic line in the right hand. Dynamic markings include *mf* and *sfp*. The tempo is marked *a tempo*. A watermark 'PROBE-PARTITUR' is visible across the page.

29

Musical score for measures 29-31. The piano part continues with the eighth-note accompaniment. Dynamic markings include *sfp* and *cresc.*. The tempo is marked *a tempo*. A watermark 'PROBE-PARTITUR' is visible across the page.

32

Musical score for measures 32-35. The piano part continues with the eighth-note accompaniment. Dynamic markings include *cresc.*. The tempo is marked *a tempo*. A watermark 'PROBE-PARTITUR' is visible across the page.

Ausgabequalität gegenüber Original evtl. gemindert • Evaluation Copy - Quality may be reduced • Carus-Verlag

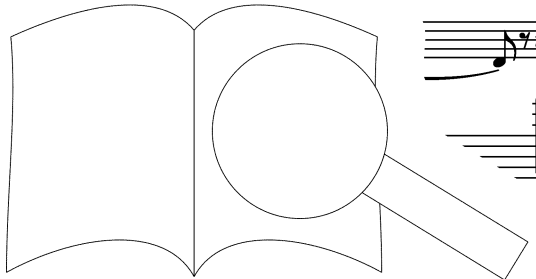

36

41

46

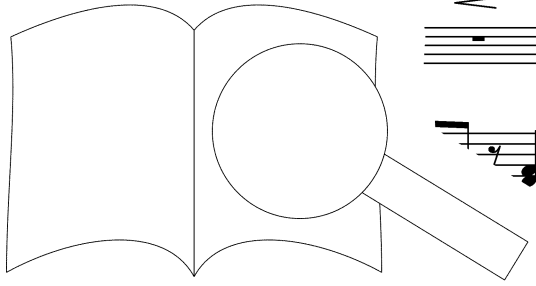

Ausgabequalität gegenüber Original evtl. gemindert • Evaluation Copy - Quality may be reduced • Carus-Verlag

57

B

Musical score for measures 57-58. The score includes five staves: four for individual instruments (flute, clarinet, violin, cello) and one grand staff for piano. Dynamics include *mf*, *cresc.*, and *pp*. A watermark "PROBEPARTITUR" is visible across the page.

58

Musical score for measures 58-63. The score includes five staves: four for individual instruments (flute, clarinet, violin, cello) and one grand staff for piano. Dynamics include *dim.* and *p*. A watermark "PROBEPARTITUR" is visible across the page.

64

Musical score for measures 64-69. The score includes five staves: four for individual instruments (flute, clarinet, violin, cello) and one grand staff for piano. Dynamics include *mf* and *p*. A watermark "PROBEPARTITUR" is visible across the page.

Ausgabequalität gegenüber Original evtl. gemindert • Evaluation Copy - Quality may be reduced • Carus-Verlag

70

Musical score for measures 70-75. The score is written for a piano and includes five staves. The piano part features a melodic line with a crescendo marking and a triplet of eighth notes. The upper staves contain vocal or instrumental parts with various note values and rests.

76

Musical score for measures 76-81. The piano part continues with a melodic line, marked with a piano (*pp*) dynamic. The upper staves show vocal or instrumental parts with various note values and rests.

82

Musical score for measures 82-87. The piano part features a melodic line with a fortissimo (*ff*) dynamic. The upper staves show vocal or instrumental parts with various note values and rests.

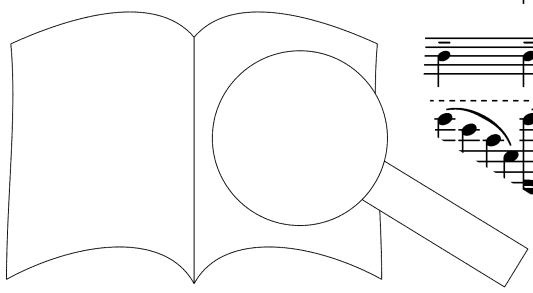

87

a tempo

pp dolce

pp dolce

8va

rit.

a tempo

dim.

pp

92

pp dolce

pp dolce

99

pp

p

f

f

©

pp

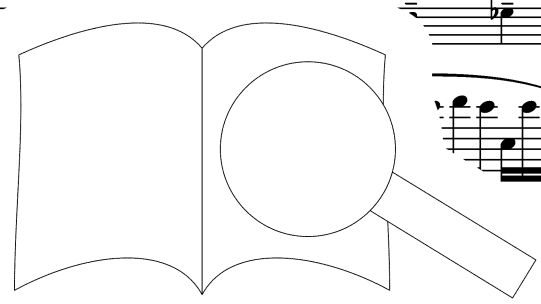

104

Musical score for measures 104-107. The score includes a piano introduction with a dense bass line and melodic lines in the upper staves. Dynamics include 'f' and 'ff'.

108

Musical score for measures 108-111. The piano part features a rhythmic pattern of eighth notes. Dynamics include 'f' and 'ff'.

112

Musical score for measures 112-115. The piano part features a rhythmic pattern of eighth notes. Dynamics include 'dim.', 'p dolce', and 'ff'. A large watermark 'PROBEPARTITUR' is overlaid on the page.

117

Musical score for measures 117-121. The score includes a vocal line with a melodic line and a piano accompaniment with a dense chordal texture. Dynamics include *p*, *p dolce*, and *dim.*

122

Musical score for measures 122-126. The piano accompaniment features a prominent triplet pattern. Dynamics include *p* and *dim.*

127

Musical score for measures 127-131. The piano accompaniment features a dense chordal texture. Dynamics include *p* and *fp*. A large watermark "PROBEPARTITUR" is overlaid on the page.

PROBEPARTITUR
 Ausgabegqualität gegenüber Original evtl. gemindert • Evaluation Copy - Quality may be reduced • Carus-Verlag

132

poco rit.

a tempo

D

136

140

Ausgabequalität gegenüber Original evtl. gemindert • Evaluation Copy - Quality may be reduced • Carus-Verlag

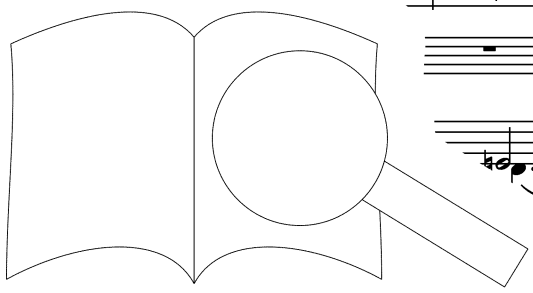

Musical score for measures 145-149. The score includes vocal staves and piano accompaniment. Dynamics include *mf* and *p*. A *cresc.* marking is present in the piano part.

Musical score for measures 150-154. The score includes vocal staves and piano accompaniment. Dynamics include *pp* and *sempre pp*. A '3' marking is present in the piano part.

Musical score for measures 155-159. The score includes vocal staves and piano accompaniment. Dynamics include *pp* and *rit.*. A large watermark 'PROBEPARTITUR' is overlaid on the page.

Musical score for measures 161-164. The vocal line includes a crescendo marking. The piano accompaniment features a triplet of eighth notes in the right hand.

Musical score for measures 165-168. The vocal line contains a fermata. The piano accompaniment includes a triplet of eighth notes in the right hand.

Musical score for measures 169-172. The vocal line includes a crescendo marking. The piano accompaniment features a triplet of eighth notes in the right hand.

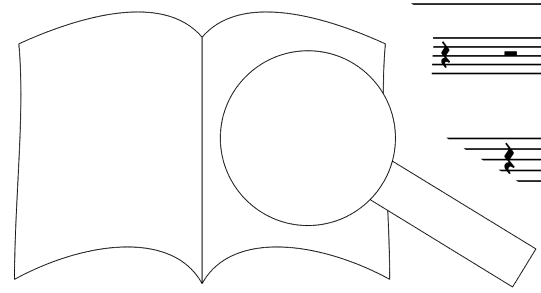

Ausgabequalität gegenüber Original evtl. gemindert • Evaluation Copy - Quality may be reduced • Carus-Verlag

174 rit. a tempo

Musical score for measures 174-177. The score is written for a piano and includes vocal lines. It features a tempo change from 'rit.' to 'a tempo'. The piano part has a complex rhythmic pattern with many sixteenth notes. Dynamics include 'p' and 'cresc.'. There are also some markings like 'rit.' and 'a tempo' above the piano part.

178

Musical score for measures 178-181. The score continues with the piano and vocal parts. It includes a 'cresc.' marking and a 'p' dynamic. There are also some markings like 'rit.' and 'a tempo' above the piano part.

182

Musical score for measures 182-185. The score continues with the piano and vocal parts. It includes a 'p' dynamic. There are also some markings like 'rit.' and 'a tempo' above the piano part.

186

cresc.

ff

190

poco a poco rit.

rit.

marcato

cresc.

3

194 **F** a tempo

dim.

cresc.

Ausgabequalität gegenüber Original evtl. gemindert • Evaluation Copy - Quality may be reduced • Carus-Verlag

Musical score for measures 202-208. The system includes vocal lines and piano accompaniment. Dynamics include *mf* and *p dolce*.

Musical score for measures 209-214. The system includes vocal lines and piano accompaniment. Dynamics include *f* and *p*.

Musical score for measures 215-219. The system includes vocal lines and piano accompaniment. Dynamics include *mf* and *f*. Includes a large watermark graphic.

Musical score for measures 221-225. The score is written for voice and piano. The voice part consists of two staves (treble and bass clef). The piano part consists of two staves (treble and bass clef). The key signature has one sharp (F#) and the time signature is 3/4. Dynamics include *sf* (sforzando) and *dim.* (diminuendo). There are several triplet markings (3) in the piano part.

Musical score for measures 226-230. The score is written for voice and piano. The voice part consists of two staves (treble and bass clef). The piano part consists of two staves (treble and bass clef). The key signature has one sharp (F#) and the time signature is 3/4. Dynamics include *ff* (fortissimo). There are triplet markings (3) in the piano part.

Musical score for measures 231-235. The score is written for voice and piano. The voice part consists of two staves (treble and bass clef). The piano part consists of two staves (treble and bass clef). The key signature has one sharp (F#) and the time signature is 3/4. Dynamics include *p* (piano) and *mf* (mezzo-forte). There are triplet markings (3) in the piano part. A guitar chord symbol 'G' is present above the first measure of the voice part.

Ausgabequalität gegenüber Original evtl. gemindert • Evaluation Copy - Quality may be reduced • Carus-Verlag

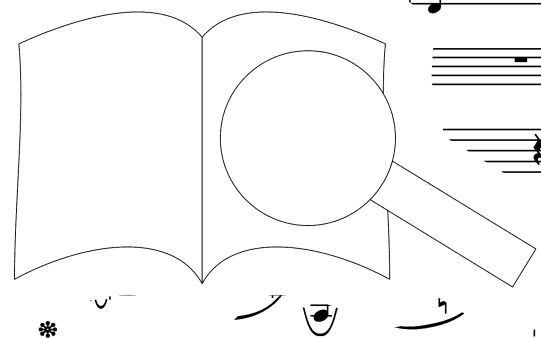

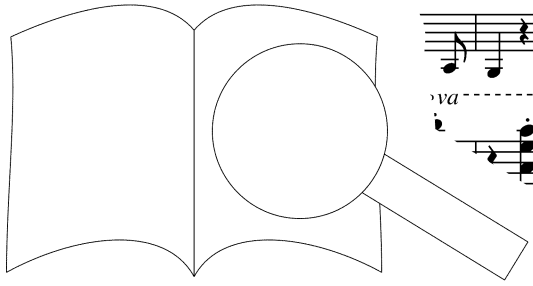

PROBEPARTITUR
 Ausgabequalität gegenüber Original evtl. gemindert • Evaluation Copy - Quality may be reduced • Carus-Verlag

triquillo

pp dolce

mf

cresc. cresc.

lento

con fuoco

cresc.

f

p

ff

p

Ausgabequalität gegenüber Original evtl. gemindert • Evaluation Copy - Quality may be reduced • Carus-Verlag

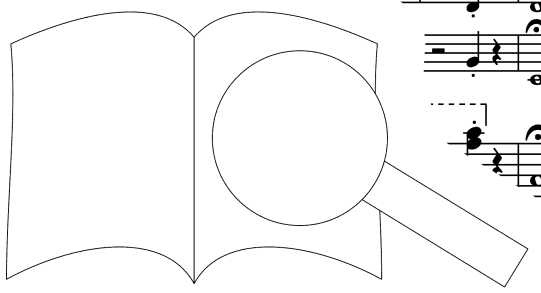

II.

Andante molto ♩ = 96

Andante molto ♩ = 96

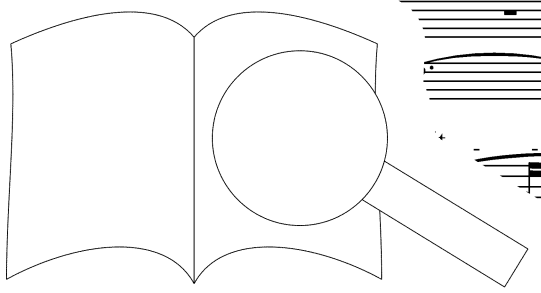

21 a tempo

a tempo

28

31

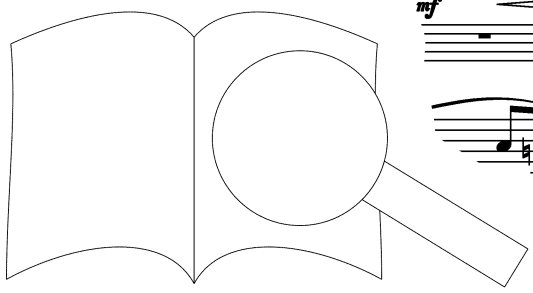

Musical score for measures 37-43. The score is written for a piano and includes a large watermark reading 'PROBEPARTITUR'. The music features a complex texture with multiple voices. Dynamics include *f*, *dim.*, and *p*. A *cresc.* marking is present in measure 41. The tempo marking *poco rit.* is at the top right.

Musical score for measures 44-52. The score continues with a large watermark 'PROBEPARTITUR'. Dynamics include *pp*, *p*, and *pp*. The tempo marking *poco più mosso espressivo* is written in the bass staff. A *dim.* marking is present in measure 48. The Carus-Verlag logo is visible on the right side.

Musical score for measures 53-60. The score continues with a large watermark 'PROBEPARTITUR'. Dynamics include *p*, *mf*, and *cres*. The Carus-Verlag logo is visible on the right side.

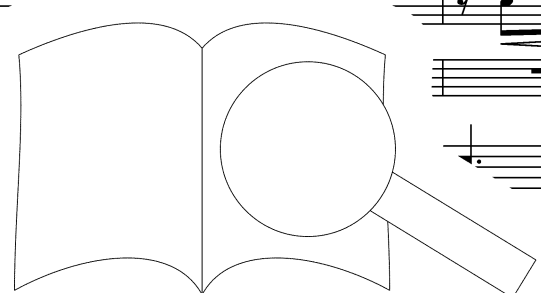

61 **B** ^{tr.}

65

69

Ausgabequalität gegenüber Original evtl. gemindert • Evaluation Copy - Quality may be reduced • Carus-Verlag

73

73

74

75

76

cresc.

This system contains measures 73 to 76. It features a vocal line in the upper staves and a piano accompaniment in the lower staves. The piano part includes a complex rhythmic pattern with sixteenth notes and rests. A 'cresc.' (crescendo) marking is present in measure 75. There are asterisks (*) under the piano part in measures 74 and 75.

77

77

78

79

80

ff

ff

This system contains measures 77 to 80. The vocal line continues with a melodic line. The piano accompaniment features a dense texture of sixteenth notes. A 'ff' (fortissimo) marking is present in measure 77. There are asterisks (*) under the piano part in measures 78, 79, and 80.

81

81

82

83

84

dim.

pp

This system contains measures 81 to 84. Measure 81 is marked with a 'C' in a box. The piano part features a melodic line with a 'dim.' (diminuendo) marking in measure 83 and a 'pp' (pianissimo) marking in measure 84. There are asterisks (*) under the piano part in measures 82, 83, and 84.

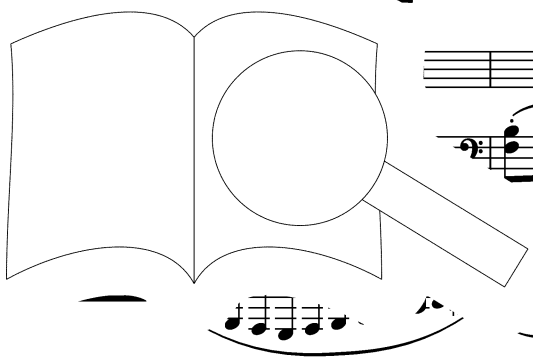

Musical score for measures 86-92. The piano part includes dynamics *f*, *p*, and *cresc.*. The violin part includes dynamics *sf* and *p*. There are *rit.* markings and asterisks in the piano part.

Tempo I

Musical score for measures 93-96. The piano part includes dynamics *ff* and *p*. The violin part includes dynamics *ff*. There are *Tempo I* markings and asterisks in the piano part.

Tempo I

Musical score for measures 97-104. The piano part includes dynamics *cresc.*, *f*, and *mf*. The violin part includes dynamics *p* and *f*. There are '3' markings for triplets and a 'D' box in the piano part.

PROBENPARTITUR
 Ausgabequalität gegenüber Original evtl. gemindert • Evaluation Copy - Quality may be reduced • Carus-Verlag

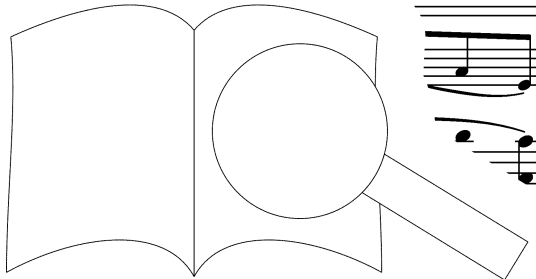

101

rit.

Musical score for measures 101-104. The score is in G major (one sharp) and 3/4 time. It consists of a piano (p) part and a grand piano (pp) part. The piano part has a melodic line with triplets and a ritardando (rit.) marking at the end. The grand piano part has a rhythmic accompaniment of triplets.

105 **poco più mosso**

Musical score for measures 105-108. The tempo is marked 'poco più mosso'. The piano part includes a 'spressivo' marking. The grand piano part features a rhythmic accompaniment with a 'cresc.' (crescendo) marking.

109

Musical score for measures 109-112. The tempo is marked 'poco più mosso'. The piano part includes a 'spressivo' marking. The grand piano part features a rhythmic accompaniment.

Musical score for measures 113-116. The score is written for a piano and voice. It features a treble and bass clef for the piano part and a single treble clef for the voice part. The key signature has two sharps (F# and C#). The piano part includes a complex rhythmic pattern with sixteenth and thirty-second notes. The voice part has a melodic line with some rests. Dynamics include *f* and *mf*. A large watermark 'PROBE-PARTITUR' is overlaid diagonally across the page.

Musical score for measures 117-120. The score continues from the previous system. The piano part features a prominent melodic line with eighth and sixteenth notes. The voice part has a melodic line with some rests. Dynamics include *mf* and *cresc.*. A large watermark 'PROBE-PARTITUR' is overlaid diagonally across the page.

Musical score for measures 121-124. The score continues from the previous system. The piano part features a prominent melodic line with eighth and sixteenth notes, including triplets. The voice part has a melodic line with some rests. Dynamics include *ff* and *ten.*. A large watermark 'PROBE-PARTITUR' is overlaid diagonally across the page.

E

Musical score for measures 125-128. The score is written for a piano and includes staves for the right hand, left hand, and grand staff. It features various dynamics such as *mf*, *f*, and *ff*. A large watermark 'PROBEPARTITUR' is overlaid diagonally across the page.

Musical score for measures 129-132. The score continues with piano and grand staff notation. Dynamics include *p* and *ff*. A large watermark 'PROBEPARTITUR' is overlaid diagonally across the page.

poco meno mosso

Musical score for measures 133-136. The score includes piano and grand staff notation. Dynamics include *f* and *ff*. A large watermark 'PROBEPARTITUR' is overlaid diagonally across the page.

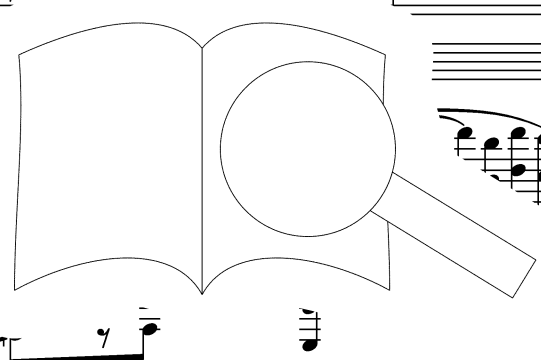

Musical score for measures 137-139. It features five staves: four for individual instruments (flute, clarinet, violin, viola) and one grand staff for piano. The piano part includes triplets and a dynamic marking of 'ff'.

Musical score for measures 140-142. It features five staves: four for individual instruments and one grand staff for piano. The piano part includes triplets and dynamic markings of 'f' and 'p'.

Musical score for measures 143-145. It features five staves: four for individual instruments and one grand staff for piano. The piano part includes triplets and dynamic markings of 'dim.' and 'p'.

146

F

151

156

rit.

Ausgabequalität gegenüber Original evtl. gemindert • Evaluation Copy - Quality may be reduced • Carus-Verlag

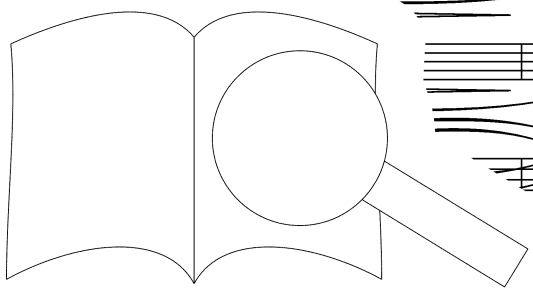

III.

Tempo di minuetto ♩ = 144

Musical score for the first system, measures 1-6. It features a piano (p) and mezzo-forte (mf) dynamic range.

Tempo di minuetto ♩ = 144
piacevole

Musical score for the second system, measures 7-12. It features a mezzo-forte (mf) dynamic range.

Musical score for the third system, measures 13-18. It features a piano (p) dynamic range.

Musical score for the fourth system, measures 19-24. It features a mezzo-forte (mf) dynamic range.

Musical score for the fifth system, measures 25-30. It features a piano (p) dynamic range.

Musical score for the sixth system, measures 31-36. It features a piano (p) and pianissimo (pp) dynamic range.

Ausgabequalität gegenüber Original evtl. gemindert • Evaluation Copy - Quality may be reduced • Carus-Verlag

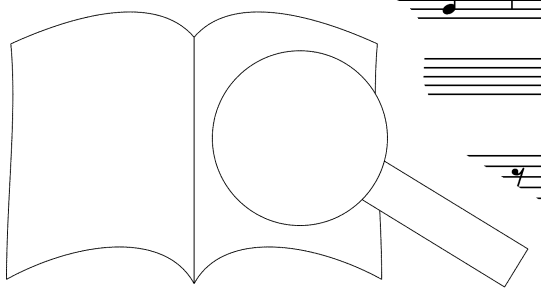

Musical score for measures 19-24. The score is written for a piano and includes five staves. The key signature has one flat (B-flat). The music features various dynamics including *f*, *sf*, and *mf*. A *dim.* (diminuendo) marking is present in measure 24. There are also some fermatas and slurs. A large watermark 'PROBEPARTITUR' is overlaid diagonally across the page.

Musical score for measures 25-30. The score continues with five staves. Dynamics include *mf*, *f*, and *sf*. A *cresc.* (crescendo) marking is present in measure 28. The watermark 'PROBEPARTITUR' is still visible.

Musical score for measures 31-34. The score continues with five staves. Dynamics include *p*, *mf*, *f*, *ff*, and *sf*. A *cresc.* (crescendo) marking is present in measure 33. The watermark 'PROBEPARTITUR' is still visible.

Musical score for measures 37-43. The score is written for voice and piano. It features a vocal line with various notes and rests, and a piano accompaniment with chords and melodic lines. A dynamic marking of *pp* is present in measure 41.

Musical score for measures 44-50. The score continues with vocal and piano parts. A dynamic marking of *f* is present in measure 48.

Musical score for measures 51-56. The score includes a vocal line and piano accompaniment. A first ending bracket is shown in measure 54, leading to a second ending. A dynamic marking of *f* is present in measure 52.

Ausgabequalität gegenüber Original evtl. gemindert • Evaluation Copy - Quality may be reduced • Carus-Verlag

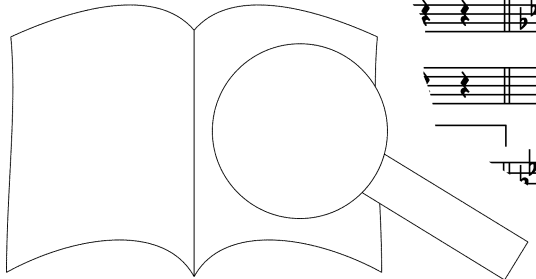

Musical score for measures 57-64. It includes vocal staves and piano accompaniment. Dynamics include *p*, *sf*, and *mf*. The piano part features a melodic line with slurs and a bass line with chords and some grace notes.

Trio

Musical score for measures 65-72. It features piano accompaniment with dynamics *p*, *mf*, and *dim.*. The piano part has a melodic line with slurs and a bass line with chords and grace notes.

Musical score for measures 65-72. It includes vocal staves and piano accompaniment. Dynamics include *p dolce*, *mf*, and *dim.*. The piano part features a melodic line with slurs and a bass line with chords and grace notes.

Musical score for measures 73-80. It includes vocal staves and piano accompaniment. Dynamics include *p cresc.*, *f*, and *rit.*. The piano part features a melodic line with slurs and a bass line with chords and grace notes.

Musical score for measures 81-88. It features piano accompaniment with dynamics *p* and *mf*. The piano part has a melodic line with slurs and a bass line with chords and grace notes.

PROBEPARTITUR

Ausgabequalität gegenüber Original evtl. gemindert • Evaluation Copy - Quality may be reduced • Carus-Verlag

81 a tempo

Musical score for measures 81-88. The score is written for a vocal line and a piano accompaniment. The vocal line features a melodic line with various ornaments and dynamics, including *ff*. The piano accompaniment consists of chords and arpeggiated figures. A large watermark 'PROBEPARTITUR' is overlaid diagonally across the page.

a tempo

Musical score for measures 89-96. The piano accompaniment continues with chords and arpeggiated figures. The vocal line has some rests. Dynamics include *ff* and *mf*. A large watermark 'PROBEPARTITUR' is overlaid diagonally across the page.

89

Musical score for measures 97-104. The piano accompaniment features a prominent arpeggiated figure. Dynamics include *ff*, *dim.*, and *p*. A large watermark 'PROBEPARTITUR' is overlaid diagonally across the page.

97

Musical score for measures 105-112. The piano accompaniment features a prominent arpeggiated figure. Dynamics include *p dolce* and *pp*. A large watermark 'PROBEPARTITUR' is overlaid diagonally across the page.

2.

rit.

empo

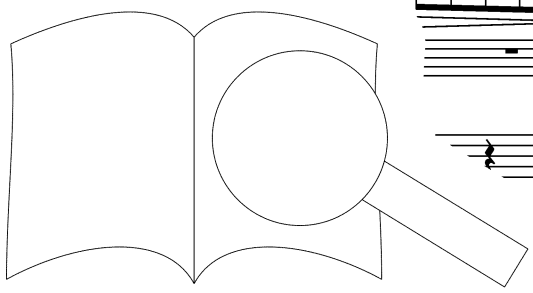

Ausgabequalität gegenüber Original evtl. gemindert • Evaluation Copy - Quality may be reduced • Carus-Verlag

Musical score for measures 124-132. The score includes a piano part (left) and a violin part (right). Dynamics include *p*, *cresc.*, *f*, and *sf*. A large watermark "PROBEPARTITUR" is overlaid diagonally across the page.

Musical score for measures 133-141. The score includes a piano part (left) and a violin part (right). Dynamics include *mf*, *cresc.*, *f*, *p*, and *cresc.*. A large watermark "PROBEPARTITUR" is overlaid diagonally across the page.

Musical score for measures 142-149. The score includes a piano part (left) and a violin part (right). Dynamics include *mf*, *f*, and *p*. A large watermark "PROBEPARTITUR" is overlaid diagonally across the page.

Musical score for measures 151-160. The score is written for a piano and includes staves for the right and left hands. A 'cresc.' marking is present in measure 152. Dynamic markings include *f* and *sf*. The piano part features complex textures with many beamed notes and slurs. There are asterisks (*) at the end of measures 152, 154, 156, 158, and 160.

Musical score for measures 160-169. The score continues with piano and right-hand parts. Dynamic markings include *f*, *sf*, and *ff*. The piano part has a more rhythmic, chordal texture. There are asterisks (*) at the end of measures 160, 162, 164, 166, 168, and 169.

Musical score for measures 169-178. The score continues with piano and right-hand parts. Dynamic markings include *pp*. The piano part features a prominent, sustained chordal texture. There are asterisks (*) at the end of measures 169, 171, 173, 175, 177, and 178.

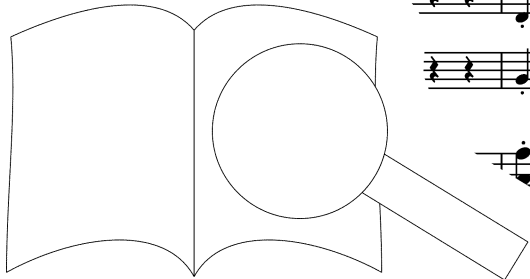

Ausgabequalität gegenüber Original evtl. gemindert • Evaluation Copy - Quality may be reduced • Carus-Verlag

IV. Finale

Allegro moderato $\text{♩} = 70$

ten.

Allegro moderato $\text{♩} = 70$

una corda

pp

5

p

tenuto

10

tutte corde

15

20

p

mf

25

p

Ausgabequalität gegenüber Original evtl. gemindert • Evaluation Copy - Quality may be reduced • Carus-Verlag

Musical score for measures 29-32. The score includes a vocal line and a piano accompaniment. The piano part features a 'cresc.' marking and dynamic markings such as 'mf' and 'ff'. Asterisks are placed under certain notes in the piano part.

Musical score for measures 33-36. The score continues the vocal and piano parts. The piano part includes dynamic markings such as 'mf'.

Musical score for measures 37-40. The score continues the vocal and piano parts. The piano part includes dynamic markings such as 'ff' and 'f'. Asterisks are placed under certain notes in the piano part.

Ausgabequalität gegenüber Original evtl. gemindert • Evaluation Copy - Quality may be reduced • Carus-Verlag

41

A

47

53

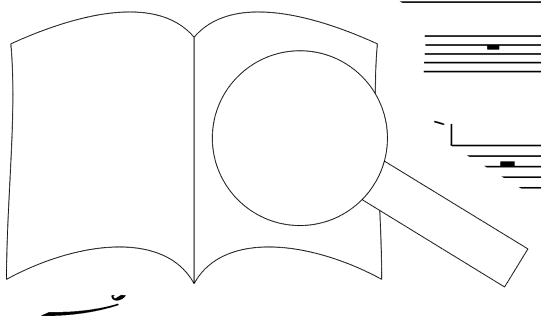

PROBE-PARTITUR
 Ausgabequalität gegenüber Original evtl. gemindert • Evaluation Copy - Quality may be reduced • Carus-Verlag

Musical score for measures 58-62. The score is written for a vocal line and a piano accompaniment. The vocal line features a melodic phrase with a slur and a fermata. The piano accompaniment consists of chords and moving lines in both hands.

Musical score for measures 63-67. The vocal line has a melodic phrase with a slur. The piano accompaniment includes triplets in the bass line and chords in the treble line. Dynamics include *dim.* and *p*.

Musical score for measures 68-72. The vocal line features a melodic phrase with a slur. The piano accompaniment includes chords and moving lines. Dynamics include *cresc.*. There are asterisks (*) at the end of some staves.

Ausgabequalität gegenüber Original evtl. gemindert • Evaluation Copy - Quality may be reduced • Carus-Verlag

Musical score for measures 73-76. The score is written for a piano and includes a large watermark reading "PROBEPARTITUR".

- Measure 73: Treble clef, piano (p), dynamic marking *mf*.
- Measure 74: Bass clef, piano (p), dynamic marking *mf*.
- Measure 75: Treble clef, piano (p), dynamic marking *mf*.
- Measure 76: Treble clef, piano (p), dynamic marking *mf*, crescendo (*cresc.*).

Musical score for measures 77-80. The score is written for a piano and includes a large watermark reading "PROBEPARTITUR".

- Measure 77: Treble clef, piano (p), dynamic marking *mf*.
- Measure 78: Bass clef, piano (p), dynamic marking *mf*.
- Measure 79: Treble clef, piano (p), dynamic marking *mf*.
- Measure 80: Treble clef, piano (p), dynamic marking *mf*, *poco rit.*

Musical score for measures 81-84. The score is written for a piano and includes a large watermark reading "PROBEPARTITUR".

- Measure 81: Treble clef, piano (p), dynamic marking *mf*.
- Measure 82: Bass clef, piano (p), dynamic marking *mf*.
- Measure 83: Treble clef, piano (p), dynamic marking *mf*.
- Measure 84: Treble clef, piano (p), dynamic marking *mf*, *rit.*, *dim.*

Ausgabequalität gegenüber Original evtl. gemindert • Evaluation Copy - Quality may be reduced • Carus-Verlag

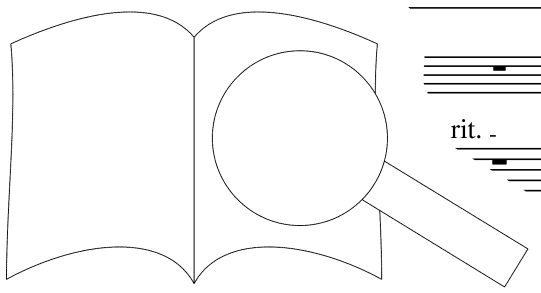

Musical score for measures 87-90. The score includes a vocal line and a piano accompaniment. The piano part features a triplet of eighth notes marked with a '3' and an asterisk. Dynamics include 'f' and 'a tempo marcato'.

Musical score for measures 91-95. The score includes a vocal line and a piano accompaniment. The piano part features a triplet of eighth notes marked with a '3' and an asterisk. Dynamics include 'p', 'smorzando', and 'cresc.'.

Musical score for measures 96-100. The score includes a vocal line and a piano accompaniment. The piano part features a triplet of eighth notes marked with a '3' and an asterisk. Dynamics include 'pp'.

Ausgabequalität gegenüber Original evtl. gemindert • Evaluation Copy - Quality may be reduced • Carus-Verlag

Musical score for measures 113-118. The score is written for a piano and includes vocal lines. The piano part features a rhythmic accompaniment with chords and moving lines. Dynamic markings include *p* and *pp*. There are also performance instructions like *rit.* and **.*

Musical score for measures 119-123. The score continues with vocal and piano parts. Dynamic markings include *p*. There are also performance instructions like *rit.* and **.*

Musical score for measures 124-128. The score includes vocal and piano parts. Dynamic markings include *p* and *cresc.*. There are also performance instructions like *rit.* and **.*

mf dolce

di-

crec

8va

ff

8va

ff

Ausgabequalität gegenüber Original evtl. gemindert • Evaluation Copy - Quality may be reduced • Carus-Verlag

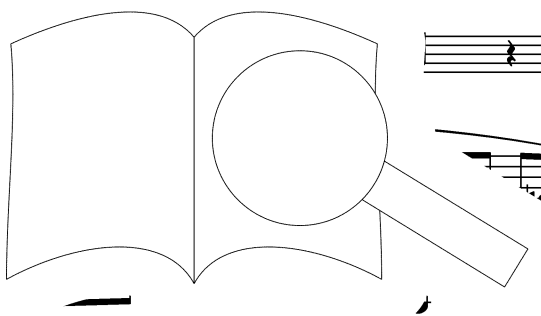

143

148

153

158

Musical score for measures 158-162. The score is in 3/4 time and features a piano accompaniment with a complex rhythmic pattern of eighth and sixteenth notes. The right hand of the piano part includes several triplet markings. Dynamics include *f* and *ff*. The upper staves show melodic lines for the vocal or instrumental part.

163

Musical score for measures 163-166. The piano accompaniment continues with triplet patterns. Dynamics include *ff* and *sf*. The word *marcato* is written above the piano part in measure 166. The upper staves show melodic lines.

167

Musical score for measures 167-170. Measure 167 begins with a key signature change to E major, indicated by a box containing the letter 'E'. The piano accompaniment features triplet patterns. Dynamics include *p dolce*. The word *marcato* is also present. The upper staves show melodic lines.

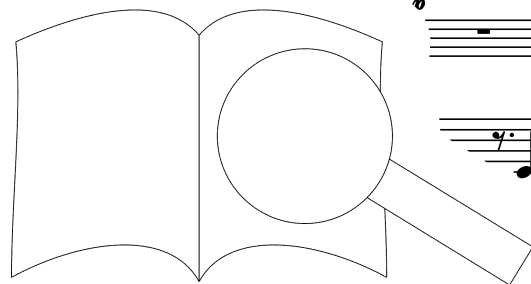

172

tuto

177

a tempo

181

ten.

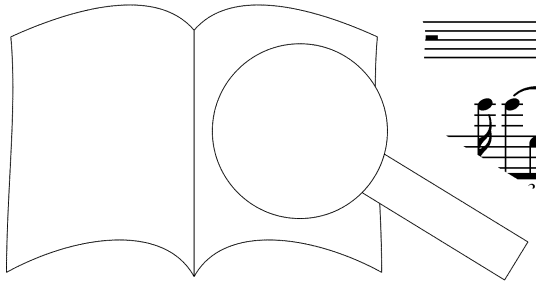

Musical score for measures 185-188. The score includes piano (p) and forte (f) dynamics. The piano part features triplets and slurs. Rehearsal marks (two dots) and asterisks are present below the piano part.

Musical score for measures 189-191. The score includes the instruction "poco a poco rit. dolce" and a piano (p) dynamic. The piano part has a long slur. Rehearsal marks and asterisks are present.

Musical score for measures 192-195. The score includes the instruction "Lento" and a forte (ff) dynamic. The piano part has a long slur. Rehearsal marks and asterisks are present.

Ausgabequalität gegenüber Original evtl. gemindert • Evaluation Copy - Quality may be reduced • Carus-Verlag

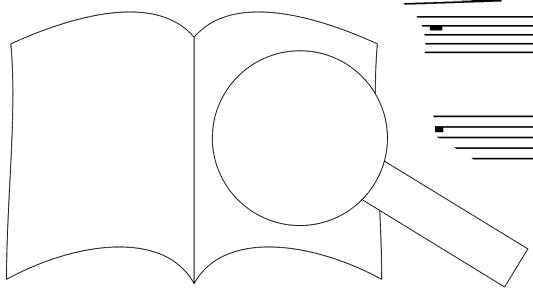

Musical score for measures 197-202. The score includes a vocal line and a piano accompaniment. The piano part features triplets and dynamic markings such as *sf* and *f*. The tempo is marked **Tempo I**.

Musical score for measures 203-208. The score includes a vocal line and a piano accompaniment. The piano part features triplets and dynamic markings such as *p*, *marc*, and *dim.*

Musical score for measures 209-214. The score includes a vocal line and a piano accompaniment. The piano part features triplets and dynamic markings such as *cresc.* and *resc.*. A large graphic of an open book is positioned at the bottom right of the page.

Musical score for measures 214-220. The score is written for a piano and includes a vocal line. The piano part features a prominent bass line with triplets and a treble part with chords and melodic lines. The vocal line consists of a single melodic line. Dynamics include *ff* and *pp*. The tempo marking *rit.* is present at the end of the section.

Musical score for measures 220-228. The score continues with piano and vocal parts. The piano part has a more active bass line with triplets. Dynamics include *ff*, *a tempo*, and *p*. The tempo marking *a tempo* is present. The vocal line continues with melodic phrases.

Musical score for measures 228-234. The score concludes with piano and vocal parts. The piano part features triplets in the bass line. Dynamics include *cresc.* and *pp*. The vocal line ends with a final melodic phrase.

PROBEPARTITUR
 Ausgabegüte gegenüber Original evtl. gemindert • Evaluation Copy - Quality may be reduced • Carus-Verlag

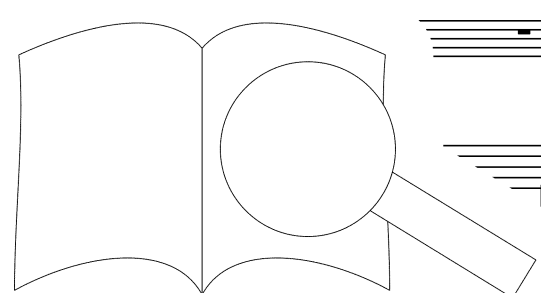

Musical score for measures 234-238. The score is written for a piano and includes a vocal line. The piano part features a complex rhythmic pattern with triplets and sixteenth notes. Dynamics include *f* (forte) and *p* (piano). A *dim* (diminuendo) marking is present in measure 238. A large watermark 'PROBEPARTITUR' is overlaid diagonally across the page.

Musical score for measures 239-242. The piano part continues with intricate rhythmic patterns, including a *cresc* (crescendo) marking in measure 241. The vocal line has a melodic contour with a slur. Dynamics include *f* and *p*. A large watermark 'PROBEPARTITUR' is overlaid diagonally across the page.

Musical score for measures 243-246. The piano part features a triplet in measure 243 and continues with complex rhythmic patterns. Dynamics include *f* and *p*. A large watermark 'PROBEPARTITUR' is overlaid diagonally across the page.

Ausgabequalität gegenüber Original evtl. gemindert • Evaluation Copy - Quality may be reduced • Carus-Verlag

smor

p

ff

p

mf

cresc.

mf

marcato

mf

marcato

mf

marcato

mf

Ausgabequalität gegenüber Original evtl. gemindert • Evaluation Copy - Quality may be reduced • Carus-Verlag

Musical score for measures 262-268. The score is written for a string quartet (Violin I, Violin II, Viola, and Cello) and a piano. The piano part includes dynamic markings such as *p dolce*, *f*, and *ff*, along with a *cresc.* (crescendo) marking. The string parts feature various articulations and dynamics, including *ff* and *f*. A large watermark 'PROBEPARTITUR' is overlaid diagonally across the page.

Musical score for measures 269-272. The score continues for the string quartet and piano. The piano part features a dynamic marking of *ff* and an *8va* (octave) marking. The string parts continue with various articulations and dynamics. A large watermark 'PROBEPARTITUR' is overlaid diagonally across the page.

Musical score for measures 273-276. The score continues for the string quartet and piano. The piano part features a dynamic marking of *ff*. The string parts continue with various articulations and dynamics. A large watermark 'PROBEPARTITUR' is overlaid diagonally across the page.

Ausgabequalität gegenüber Original evtl. gemindert • Evaluation Copy - Quality may be reduced • Carus-Verlag

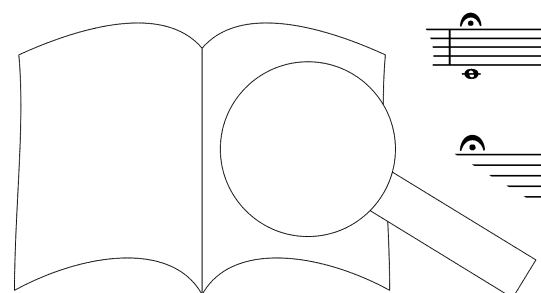

PROBE-PARTITUR

PROBE-PARTITUR
Ausgabequalität gegenüber Original evtl. gemindert • Evaluation Copy - Quality may be reduced • Carus-Verlag 

