

Helmut Barbe

Te Deum 1976

Bariton solo, drei gemischte Chöre
Flöte, 2 Oboen, 2 Fagotte
2 Trompeten, 3 Posaunen
Pauken, Glockenspiel
2 Violinen, Viola
Violoncello, Kontrabass

Partitur / Full score

Besetzung:

Hauptchor, 4 - 8 gemischte Stimmen

Fern-Chor I, 4 - 5 gemischte Stimmen F I

Fern-Chor II (Knabenchor), 3 - 6 gemischte Stimmen F II

Bariton-Solo (Umfang: G - as')

Orchester: Flöte
2 Oboen
2 Fagotte
2 Trompeten in B (nichttransponierend notiert)
3 Posaunen
Pauken
Glockenspiel
Streicher

Aufstellung:

Hauptchor zusammen mit Solist und Orchester

Fern-Chor I entfernt in Sichtweite (möglichst eigener Dirigent)

Fern-Chor II möglichst weit entfernt (unbedingt eigener Dirigent)

Zu diesem Werk liegt folgendes Aufführungsmaterial vor:
Partitur (Carus 10.213),
Chorpartitur Hauptchor und Fernchor I (Carus 10.213/05),
Chorpartitur Fernchor II (Carus 10.213/06),
komplettes Orchestermaterial (Carus 10.213/19).

7

ppp

F I S A T B

Ob 1 2

Tr 1 2

Pos 1 2

Pk

S 1 2

A 1 2

T 1 2

B 1 2

1 2

4

PROBENPARTITUR

Ausgabequalität gegenüber Original evtl. gemindert • Evaluation Copy - Quality may be reduced • Carus-Verlag

Te - - - - - mus,

lau - da - - - - mus,

um lau - da - - - - mus,

- um, te De - um,

De - um, te De - um,

m, te De - um, te De - um,

je - um, te De - um, te De - um, te De - um,

te De - um, te De - um, te De - um, te De - um,

sema vibrato

ritard. →

14

F I

Soprano (S): *f* A ————

Alto (A): *f* A ————

Tenore (T): *f* A ————

Basso (B): *f* A ————

Flauto I (Fl): *f* ————

Oboe I (Ob 1): *f* ————

Oboe II (Ob 2): *f* ————

Fagotto I (Fg 1): *f* ————

Contrabbasso (Cb): *f* ————

Soprano (S): *f* te De - um lau - da - mus, te De - um lau - da - mus,

Alto (A): *f* te De - um lau - da - mus, te De - um lau - da - mus,

Tenore (T): *f* te De - um lau - da - mus, te De - um lau - da - mus,

Basso (B): *f* te De - um lau - da - mus, te De - um lau - da - mus,

Violino I (Vn 1): *f* ————

Violino II (Vn 2): *f* ————

Viola (Vla): *f* ————

Violoncello I (Vcl 1): *f* Solo *gliss.* ————

Violoncello II (Vcl 2): *f* Solo *gliss.* ————

Contrabbasso (Cb): *f* arco *gliss.* ————

Double Bass (Cb): *f* arco *gliss.* ————

PROBENPARTITUR

Ausgabequalität gegenüber Original evtl. gemindert • Evaluation Copy - Quality may be reduced • Carus-Verlag

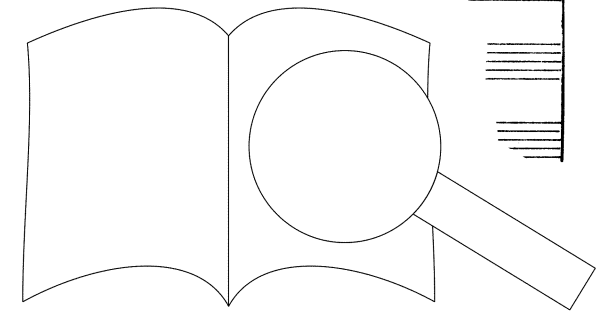

animato

♩ = ca 60

17

Fl

mf

ob

mf

Fag

mf

Tr

mf

Pos2

f

Pk

f

S

A

te Do-mi-num con-fi-te-mur,

T

B

.. Pa-trem om-nis ter-ra ve-ne-ra-tur.

Vi

p

Vla

p

Vc

p

K

f

PROBEEPARTITUR
Ausgabequalität gegenüber Original evtl. gemindert • Evaluation Copy - Quality may be reduced • Carus-Verlag

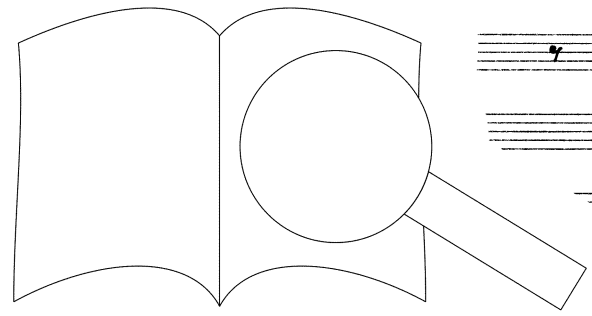

21

Fl 1
Fl 2

Ob 1
Ob 2

Fg 1
Fg 2

Tr 1
Tr 2

Pos 2
Pos 3

Pk

S
A
T
B

Vi 1
Vi 2

Vla
Vc
Cb

mf f
mf f
mf f
mf f
mf f
mf f
mf f
mf p
mf p
mf f

ta - tes, ti - bi Che - in - ces - sa - bi - li vo - ce cla - ma - bant, in - ces -

PROBEEPARTITUR

Ausgabequalität gegenüber Original evtl. gemindert • Evaluation Copy - Quality may be reduced • Carus-Verlag



ritard.

Sehr ruhig

$\text{♩} = 46$

23

1

Fg

2

Pk

S

A

T

1

B

2

1

2

Vl

Vla

1

Vc

2

Kb

p

pp

pp cresc

Sanc

Sanc,

sanc-tus, sanc

Sa-bi-li vo-ce cla-ma-bant:

Sa-bi-li vo-ce cla-ma-bant:

Solo

Solo

Solo

Solo

28
 S
p
 Sanc-tus Do-mi-nus, De-us Sa-ba-oth, sanc-tus Do-mi-nus De-us Sa-ba-oth, sanc-tus Do-mi-nus De-us Sa-ba-oth,

Fl
 1
 Ob
 2
 Tr 1
 1
 Pos
 3

S
 A
 T
 B
 sanc
 sanc
 sanc
 sanc
 tus,
 tus,
 tus,
 tus,

1
 Vi
 2
 Vla
 Vc
 I
 tutti
 tutti

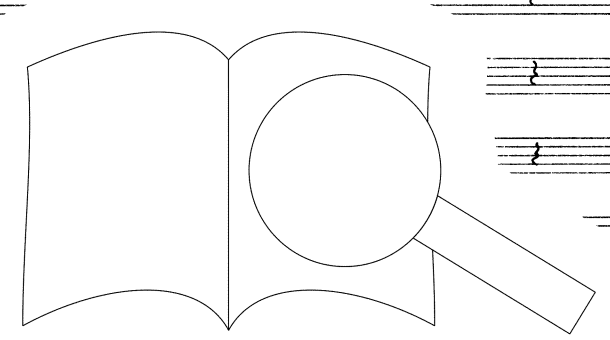

PROBEEPARTITUR
 Ausgabqualität gegenüber Original evtl. gemindert • Evaluation Copy - Quality may be reduced • Carus-Verlag

3
4

32
F I S
sanc-tus Do - mi-nus De-us Sa-ba-oth, sanc-tus Do - mi-nus De-us Sa-ba-oth, sanc-tus Do - mi-nus De-us Sa-ba-oth

3
4
P HYMNUS: Guillaume Dufay

F II S A T B
Con - - - di - - tor al - - me si - - ae -
Con - - - di - - tor al - - me s: - - ae -
Con - - - di - - tor al - - - - - rum, ae -

3
4

S
A
T
B

3
4

1
VI
2
Vla
Vc
Kb

ba-oth, Sanc-tus Do-mi-nus De-us Sa-ba-oth, Sanc-tus Do-mi-nus De-us Sa-ba-oth, Sanc-tus Do-mi-nus De-

ter - - - na lux cre - den - - - ti - um,

ter - na lux cre - - den - ti - - -

Sanc - - - pos.nat. Sanc -

pos.nat. p

4/4

PROBEEPARTITUR

Ausgabequalität gegenüber Original evtl. gemindert • Evaluation Copy - Quality may be reduced • Carus-Verlag

47

3
4

F I S

ba - oth, sanctus Do - mi - nus De - us Sa - ba - oth, sanc - tus Do - mi - nus De - us Sa - ba - oth, sanc - tus Do - mi - nus De - us Sa - ba - oth, sanc - tus Do - mi - nus

3
4

F II S A T B

Chri - ste re - demp - - tor om - ni - um, ex -

Chri - ste re - demp - - tor om - ni - um,

3
4

Fl

1 Ob

2

Tr-1

1 Pos

3

3
4

S A T B

3
4

1 Vc

2

Vc

Kb



PROBENPARTITUR
Ausgabequalität gegenüber Original evtl. gemindert • Evaluation Copy - Quality may be reduced • Carus-Verlag

poco animato

$\text{♩} = ca. 54$

52

F I S

De-us Sa-ba-oth, sanc-tus Do-mi-nus De-us Sa-ba-oth, sanc-tus Do-mi-nus De-us Sa-ba-oth!

F II S A T B

au - - - di pre - - - ces sup - - pli - - cum.

au - - - di pre - - - ces sup - - pli - - cum.

au - - - di pre - - - ces sup - - - pli - cum.

Tr 1 2

Pos 1 2 3

S 1 2

A

T

B

coe - - li et ter-ra

ni sunt coe - - li et ter-ra

ple - ni sunt coe - - li et ter-ra

ple - ni sunt coe - - li et ter-ra

VI 1 2

Vla

Vcl

Kl

pos.nat. f

pos.nat. f

PROBE PARTITUR

Ausgabequalität gegenüber Original evtl. gemindert • Evaluation Copy - Quality may be reduced • Carus-Verlag

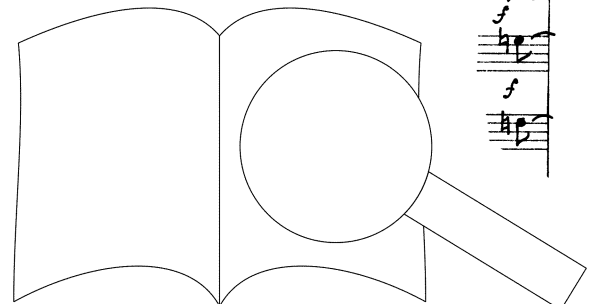

57 *mf* **4** **4** *p*

F I
 1 ma - ie - sta - te glo - ri - ae, *hd.* glo - - - ri - - -
 2 ma - ie - sta - te glo - ri - ae, *hd.* glo - - - ri - - -
 A ma - ie - sta - te glo - ri - ae, *hd.* glo - - - ri - - -
 T ma - ie - sta - te glo - ri - ae, *hd.* glo - - - ri - - -
 B ma - ie - sta - te glo - ri - ae, *hd.* glo - - - ri - - -

Fi *mf* **4** **4**

Tr
 1 *mf*
 2 *mf*
 1 *mf*
 Pos 2 *mf*
 3 *mf*

4 **4** *mf*

S
 1 *p.*
 2 *p.*
 A *p.*
 T *p.*
 B *p.*

ae.
 #p
 ae.
 #p
 #ae.
 #p

VI
 1
 2

V
 1
 2

Kb

4

PROBEPARTITUR
 Ausgabequalität gegenüber Original evtl. gemindert • Evaluation Copy - Quality may be reduced • Carus-Verlag

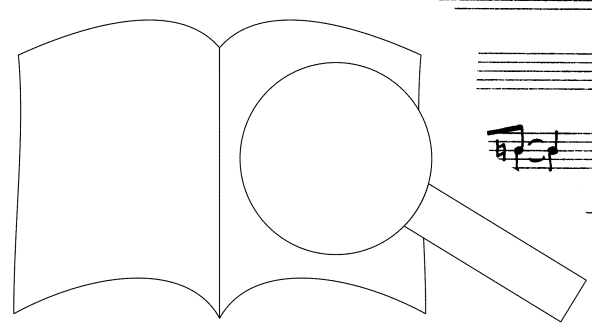

62

Soprano I
 Alto
 Tenor
 Bass

ae

1
 2
 1
 2

Ob
 Fg
 Fg

f
 f
 p marcato
 p marcato

1
 2
 1
 2
 3

Tr
 Pos 2
 Pos 3

pp
 pp
 pp

pp marcato

Soprano
 Alto
 Tenor
 Bass

tu - - - - - ae.
 tu - - - - -
 tu - - - - -
 tu - - - - -

pp
 p marcato (non stacc!)

Te glo-ro-sus,

1
 2
 1
 2

Vi
 Vla
 Vc
 Kb

pp
 mp
 mp

pizz sec
 mp
 pizz se
 mp

PROBEPARTITUR

Ausgabequalität gegenüber Original evtl. gemindert • Evaluation Copy - Quality may be reduced • Carus-Verlag

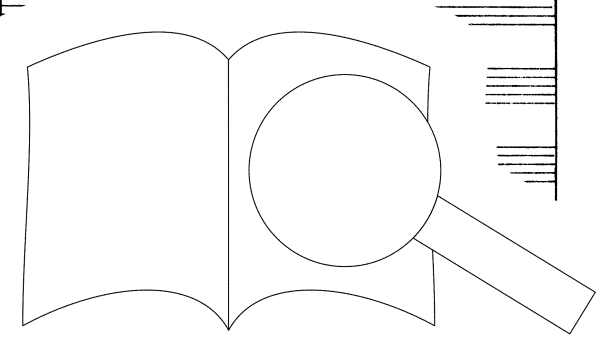

67

Fl 1
Ob 1
Ob 2
Fg 1
Fg 2
Tr 1
Tr 2
Pos 2
Pos 3
S
A
T
B
Vi 1
Vi 2
Vc 1
Vc 2
Cb

mf

mf

mf

mf

te glo-ro-sus A

te glo-ro-sus A-po-stu-lo-rum cho-rus, te glo-ro-sus

te Pro-phe-ta-rum lau-da-bi-lis nu-me-rus, te

te Mar-

div Soli
arco

div Soli
p

69

Fl
1
Ob
2
1
Fg
2

Tr
2
1
Pos 2
3

S
A
T
B

ty-rum can-di-da-tus lau-dat ex-er-ci-tus, te Mar-ty-ru la-ti-lat ex-er-ci-tus. Te per or - - - bem
Pro-phe-ta-rum lau-da-bi-lis nu-me-rus Te per or - - - bem
A - po - stu - lo - rum cho - rus. Te per or - - - bem

1
2
Vla
Vc
Kb

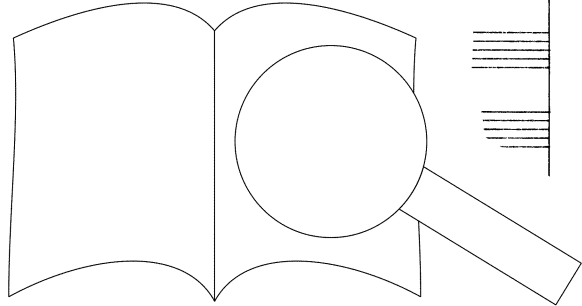

PROBENPARTITUR
Ausgabequalität gegenüber Original evtl. gemindert • Evaluation Copy - Quality may be reduced • Carus-Verlag

72

Fl

1 Ob

2 Ob

1 Fg

2 Fg

1 Tr

2 Tr

1 Pos 2

3 Pos 2

con Sord

p

Sub.p

mf

S

A

T

B

1 Vi

2 Vi

Vc

Kb

ter-ra-rum sanc-ta con-fi-ti-si-a, Pa-trem im-men-sae ma-ie-

ter-ra-rum Ecc-le-si-a, Pa-trem im-men-sae ma-ies-ta-tis,

Empty musical staves for various instruments.

74

Flute (Fl) and Oboe (Ob) staves with musical notation. Bassoon (Fg) staves with musical notation and the instruction *f espr*.

Trumpet (Tr) and Trombone (Pos 2, 3) staves with musical notation. The instruction *f* is present.

Vocal staves (Soprano, Alto, Tenor, Bass) with lyrics: *sta-tis, Pa-trem im-men-sae ma-ie-sta-tis, ve-... um u-ni-cum Fi-li-um sanc-tam quo-que*. The instruction *f espr* is present.

Violin (Vi), Viola (Vla), Violoncello (Vc), and Kontrabaß (Kb) staves with musical notation. A large graphic of an open book is overlaid on the bottom right.

PROBEPARTITUR
Ausgabequalität gegenüber Original evtl. gemindert • Evaluation Copy - Quality may be reduced • Carus-Verlag

ritard → sehr ruhig

♩ = ca 46

Fl
f espr

Ob
f espr

Fg
f espr

Tr

Pos 2

3

Pk
f *ff* *pp*

Glsp

S
pa-ra-cli-tum Spi-ri-tum. Sanc,

A
pa-ra-cli-tum Spi-ri-tum. Sanc,

T
pa-ra-cli-tum Spi-ri-tum. Sanc,

B
pa-ra-cli-tum Spi-ri-tum. Sanc,

VI

Kb
f espr *piaz* *ff*

PROBEPARTITUR
Ausgabequalität gegenüber Original evtl. gemindert • Evaluation Copy - Quality may be reduced • Carus-Verlag

82

Flauto I

Flauto II

Violini I

Violini II

Violoncelli

Contrabbassi

3
4

82

Flauto I

Flauto II

Violini I

Violini II

Violoncelli

Contrabbassi

3
4

p

Sanc-tus Do-mi-nus De-us Sa-ba-oth, sanc-tus Do-mi-nus De-us Sa-ba-oth, sanc-tus Do-

Flauto I

Oboboi

Fagotti

Clarinetti

3
4

Flatterzunge *f* *pp* *8va*

Clarinetti

Flauto I

Flauto II

Violini I

Violini II

Violoncelli

Contrabbassi

3
4

Soprano

Alto

Tenore

Bass

3
4

pp *f*

Sanc-tus, sanc-tus!

Sanc-tus, sanc-tus!

Sanc-tus, sanc-tus!

Violini I

Violini II

Violoncelli

Contrabbassi

3
4

Sul tasto *pp* *pp* *pp*

Violini I

Violini II

Violoncelli

Contrabbassi

3
4

PROBENPARTITUR

Ausgabequalität gegenüber Original evtl. gemindert • Evaluation Copy - Quality may be reduced • Carus-Verlag

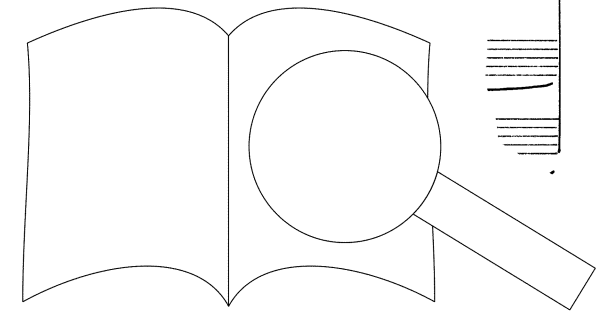

87

3
4

F I S

- mi-nus De-us Sa-ba-oth, sanc-tus Do-mi-nus De-us Sa-ba-oth, sanc-tus Do-mi-nus De-us Sa-ba-oth, Sanc-tus Do-mi-nus De-us Sa-ba-oth!

3
4

F II S

A

T

1

B

2

P SANCTUS aus REQUIEM: Pierre de la Rue

Sanc - - - - - tus,

Sanc - tus,

Sanc - tus,

Sanc - tus,

Sanc - tus,

3
4

Fl

Ob1

1

Fg

2

Clsp

3
4

S

A

T

1

B

2

3
4

1

Vi

2

Vi

Kb

PROBENPARTITUR

Ausgabequalität gegenüber Original evtl. gemindert • Evaluation Copy - Quality may be reduced • Carus-Verlag

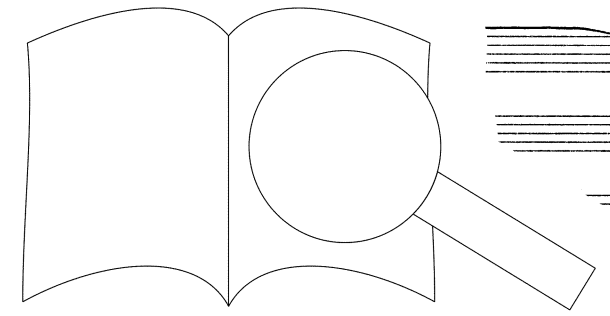

92

F II

S
A
T
1
B
2

Sanc - - - - tus Do - - - - mi - - -

tus, sanc - - - - tus, sanc - - - - tus Do - - - -

sanc - - - - tus Do - mi - nus De - us Sa - - - -

sanc - - - - tus, sanc - - - - tus Do - - - - mi -

sanc - - - - tus Do -

VI
1
2

101

F II

S
A
T
1
B
2

nus De - - - - us So Sa - - -

- mi - - - - nus De - - - - Sa - - - -

- - - - ba - - - -

nus De - - - - us oth, Sa - - -

mi - nus De - us Sa - - -

Pk

tr
ppp sempre poco a poco

PROBEPARTITUR

Ausgabequalität gegenüber Original evtl. gemindert • Evaluation Copy - Quality may be reduced • Carus-Verlag

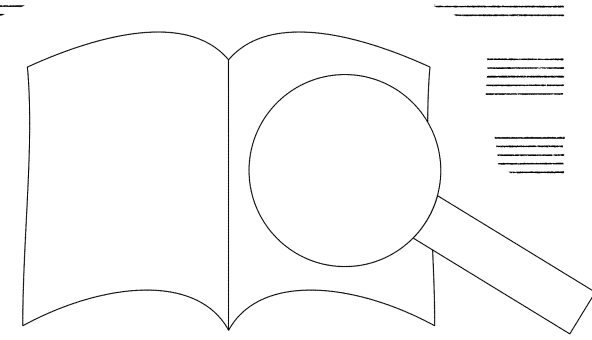

108 *f* *ritard* →

F I
S
A
T
B

F II
S
A
T
B 1
B 2

Fl
Ob¹₂
Fg¹₂
Tr-1
Pk
Gisp

S
A
T
B

Vi¹₂
Vla
Kb

f *ritard* →

4 *4* *4* *4*

cresc. *f* *ppp*

senza sord.

Solo f gliss *Tutti*

f *pizz* *arco* *f*

la - da - mus, te De - um lau - da - mus, te De - um lau - da - mus!
 lau - da - mus, te De - um lau - da - mus, te De - um lau - da - mus!
 lau - da - mus, te De - um lau - da - mus, te De - um lau - da - mus!
 lau - da - mus, te De - um lau - da - mus, te De - um lau - da - mus!

PROBENPARTITUR
 Ausgabequalität gegenüber Original evtl. gemindert • Evaluation Copy - Quality may be reduced • Carus-Verlag

II

Bewegt

♩ = ca 76 beginnend

Fl
Ob 2
Fg 1
Bariton-Solo
Soprano
Alto
Tenor
Bass
Vi 1
Vi 2
Vla
Vc
Kb

p poco a poco cresc
Tu Rex glo-ri-ae Chri-ste, tu Rex glo-ri-ae, tu Rex glo-ri-ae Chri-ste,
cresc
tu Rex glo-ri-ae,
p cresc
mp cresc

PROBEEPARTITUR
Ausgabequalität gegenüber Original evtl. gemindert • Evaluation Copy - Quality may be reduced • Carus-Verlag

8

Fl 1 *mf cresc* *f*

Ob 1 *f*

2 *mf cresc* *f*

Fg 1 *mf cresc* *f*

Solo *mf cresc* *f*

S *mf cresc* *f*
tu Rex glo-ri-ae Chri-ste, tu Rex

A
tu Rex glo-ri-ae Chri-ste

T
tu Rex glo-ri-ae Chri-ste

B

VI 1 *mf espr*

2 *mf espr*

Vla *mf espr*

ae Chri - - - - ste,

Empty musical staves for woodwinds and strings.

16
 Ob 1
 Solo
 Musical notation for Oboe 1 and Solo parts, including dynamic markings and time signatures (2/8, 6/8).

Soprano (S), Alto (A), Tenor (T), Bass (B)
p poco a poco cresc
 tu Rex glo-ni-ae Chri-ste, tu Rex gl
 -ni-ae, tu Rex glo-ni-ae Chri-ste,
 tu Rex glo-ni-ae,
cresc

Violin 1 (V1), Violin 2 (V2), Viola (Vla), Violoncello (Vc), Kontrabaß (Kb)
p cresc
pizz p cr
arco p cresc
mp cresc
mp cr

PROBEEPARTITUR
 Ausgabequalität gegenüber Original evtl. gemindert • Evaluation Copy - Quality may be reduced • Carus-Verlag

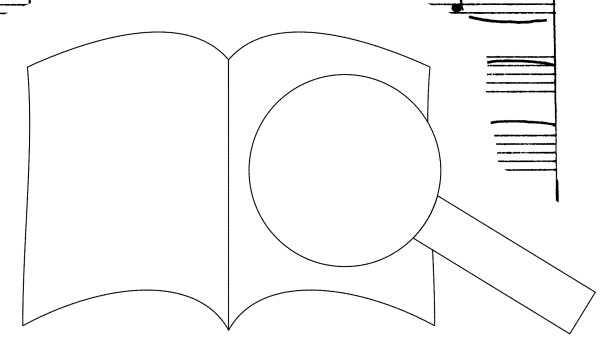

Empty musical staves for various instruments.

31
 Fl
 Ob2
 1
 Fg
 2
 Solo
 us,
 mp cresc
 mp cresc
 p
 mp cresc
 cresc

Soprano
 Alto
 Tenor
 Bass
 tu Rex glo-ri-ae
 tu Rex glo-ri-ae Chri-ste, tu
 tu Rex glo-ri-ae Chri-ste, tu
 glo-ri-ae, tu Rex glo-ri-ae Chri-ste, tu Rex glo-ri-ae
 p poco a poco cresc
 mf cresc

1
 2
 VI
 Vla
 Vc
 Kb
 p cresc
 mp cresc
 mp cresc

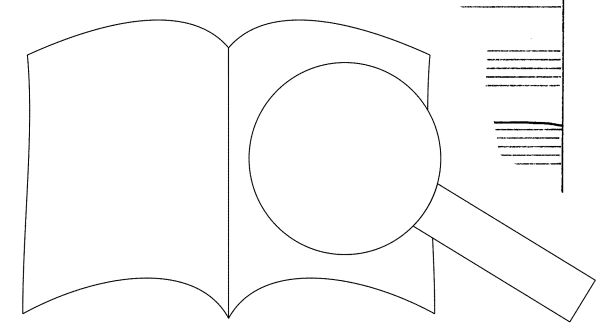

PROBEPARTITUR
 Ausgabqualität gegenüber Original evtl. gemindert • Evaluation Copy - Quality may be reduced • Carus-Verlag

Fl 3g

Ob 1 2

Fg 1 2

Solo

Soprano (S)

Alto (A)

Tenor (T)

Bass (B)

Vl 1 2

Vla

tu ad li - - be - ram - - mi - nem

Chri - ste, tu Rex glo - ri - ae Chri - ste,

Chri - ste, tu Rex glo - ri - ae Chri - ste,

Chri - ste, tu Rex glo - ri - ae Chri - ste,

Chri - ste, tu Rex glo - ri - ae Chri - ste,

f, *f esp*, *p poco a poco cresc*

2/8, 6/8, 2/8, 6/8, 2/8, 6/8

PROBEEPARTITUR

Ausgabequalität gegenüber Original evtl. gemindert • Evaluation Copy - Quality may be reduced • Carus-Verlag

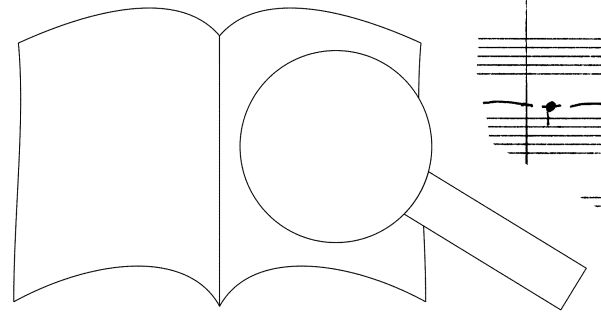

48

Fl

Ob

Cl

Solo

S

A

T

B

Vi

Vla

Vc

Cb

mp cresc

p cresc

mp cresc

p cresc

mp cresc

mp po

mf cresc

p cresc

mp cresc

mp cresc

cresc

nec hor - ru - i - - sti nis u - - te - -

tu Rex glo - ri - ae Chri - ste, tu Rex glo - ri - ae,

tu Rex glo - ri - ae Chri - ste, tu Rex glo - ri - ae

tu Rex glo - ri - ae Chri - ste, tu Rex glo - ri - ae

tu Rex glo - ri - ae Chri - ste, tu Rex glo - ri - ae

6 2 6 2 6 2 6 2

8 8 8 8 8 8 8 8

Sehr langsam

56 *♩ = ♩* *Sehr akzentuiert geflüstert* *f* *3*

T
S
A
T
B

T
S
A
T
B

2 6 4
8 8 4

Tr 1
2

Pos 1
2
3

Pk

Gesp

2 6 4
8 8 4

Solo

rum.

f

S
A
T
B

Chri-ste, tu Rex glo-ri-ae Chri-ste. de- - vic - to

Chri-ste, tu Rex glo-ri-ae Tu de- - vic - to

con sord *p* *tr. rum., tr.*

con sord *pp* *8va*

con sord *pizz* *p marc.*

Carus-Verlag

61

F I S A T B tu Rex glo-ri-ae Chri-ste, tu Rex glo-ri-ae Chri-ste,

F II S A T B glo-ri-ae Chri-ste, tu Rex glo-ri-ae Chri-ste

5
4

4
4

Ob 1 2

Tr 1 2

Pos 1 2 3

Pk *Kamm Horn*

Gisp

5
4

4
4

S mor - le - - - a - pe -

A - - - - -

T - - - - -

B cu - - - le - - - a - pe -

4
4

4
4

Vi 1 2

Vla

Vc

Kb

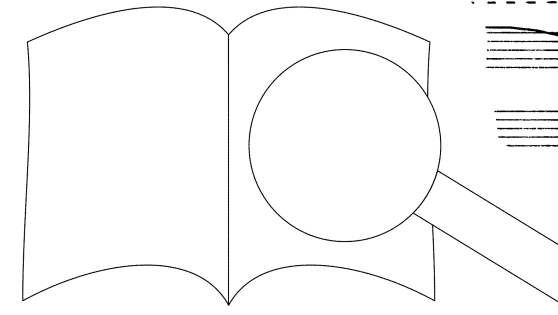

PROBEPARTITUR
Ausgabequalität gegenüber Original evtl. gemindert • Evaluation Copy - Quality may be reduced • Carus-Verlag

64

F I S A T B tu Rex glo-ri-ae Chri-ste,

F II S A T B tu Rex glo-ri-ae Chri-ste,

5 4 4

1 Ob

2 Ob

1 Tr

2 Tr

1 Pos 2

3 Pos 2

Pk

Gisp

5

S - - ru - - i - - sti cre - ti d - na coe - lo -

A - - ru - - i - - ti - bus reg - na coe - lo -

T - - ru - - i - -

B - - ru - - i - -

5 4 4

1 Vi

2 Vi

Vc

Kb

PROBENPARTITUR

Ausgabequalität gegenüber Original evtl. gemindert • Evaluation Copy - Quality may be reduced • Carus-Verlag

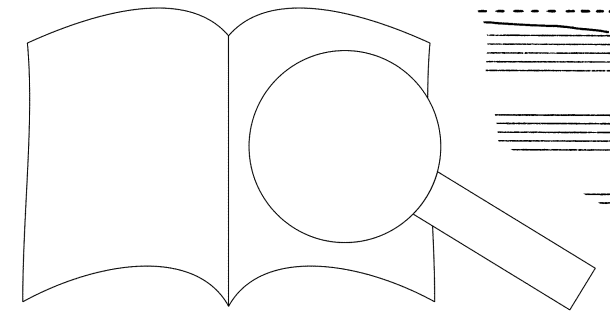

bewegt

68

F I S A T B tu Rex glo-ri-ae Chri-ste, tu Rex glo-ri-ae Chri-ste.

F II S A T B tu Rex glo-ri-ae Chri-ste.

Ob2

Fg 1 2

p molto cresc

Tr 1 2

Pos 2 3

Pk

Glsp

S A T B - - rum. - Rex glo-ri-ae Chri-ste, tu Rex glo-ri-ae Chri-ste, Tu Rex glo-ri-ae Chri-ste, tu Rex glo-ri-ae Chri-ste

1 2

Vla

Vc

Kb

PROBEPARTITUR

Ausgabequalität gegenüber Original evtl. gemindert • Evaluation Copy - Quality may be reduced • Carus-Verlag

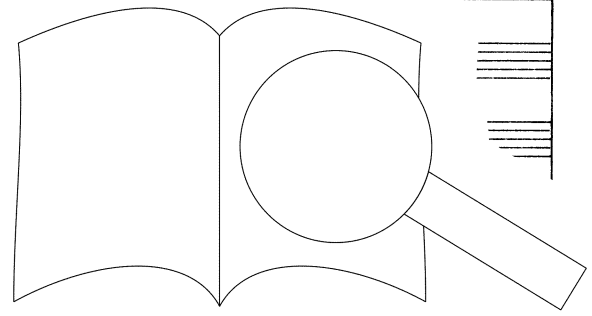

Empty musical staves for various instruments, including woodwinds and strings.

81
Ob2
1
Fg
2
Solo
p molto cresc
p molto
f
in glo - - ri - ae p is,

S
A
T
B
Chri - ste, tu Rex glo - ri - ae Chri - ste,
Chri - ste, tu Rex glo - ri - ae Chri - ste,
Chri - ste, tu Rex glo - ri - ae Chri - ste,
Chri - ste, tu Rex glo - ri - ae Chri - ste,

2 6 2 6 2 6
8 8 8 8 8 8
Vi
2
Via
Vc
Kb
pizz
p

PROBEEPARTITUR
Ausgabequalität gegenüber Original evtl. gemindert • Evaluation Copy - Quality may be reduced • Carus-Verlag

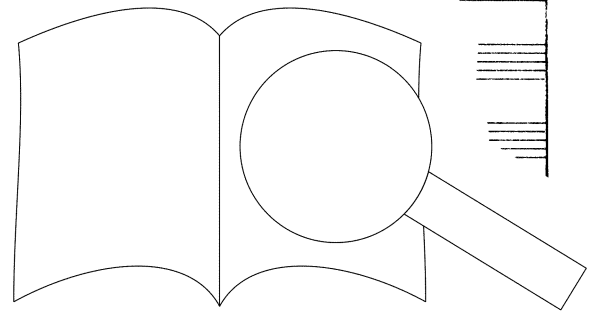

90

Fl *f molto cresc* *ff* $\lfloor 2 \rfloor$ $\lfloor 2 \rfloor$

Ob *f molto cresc* *ff* $\lfloor 2 \rfloor$ $\lfloor 2 \rfloor$

Fg *ff* $\lfloor 2 \rfloor$ $\lfloor 2 \rfloor$

Tr *ff* $\lfloor 2 \rfloor$ $\lfloor 2 \rfloor$ *f*

Pos 2 *f* *gliss*

Pos 3 *f*

Pk Δ *gliss* *f*

Glsp *f*

Solo *f* *decrease*

S *f* $\lfloor 2 \rfloor$ $\lfloor 2 \rfloor$ $\lfloor 2 \rfloor$ $\lfloor 2 \rfloor$
tu Rex glo-ri-ae Chri-ste, Chri-ste, Chri-s.

A $\lfloor 2 \rfloor$ $\lfloor 2 \rfloor$

T $\lfloor 2 \rfloor$ $\lfloor 2 \rfloor$

B $\lfloor 2 \rfloor$ $\lfloor 2 \rfloor$
tu Rex glo-ri-ae Chri-ste

Vi

Vr

Kb *f* *arco*

pp marcato

co

co.

pp marcato

se ven - - tu - - rus.

PROBEEPARTITUR

Ausgabequalität gegenüber Original evtl. gemindert • Evaluation Copy - Quality may be reduced • Carus-Verlag

ruhig

♩ = ca 52

98

Ob 1

1

2

Tr 1

1

Pos 2

3

Pk

Solo

er - go, te er-go, te quae-su-rus, -

VI 1

2

Vla

Vc

Kb

PROBEEPARTITUR
Ausgabequalität gegenüber Original evtl. gemindert • Evaluation Copy - Quality may be reduced • Carus-Verlag

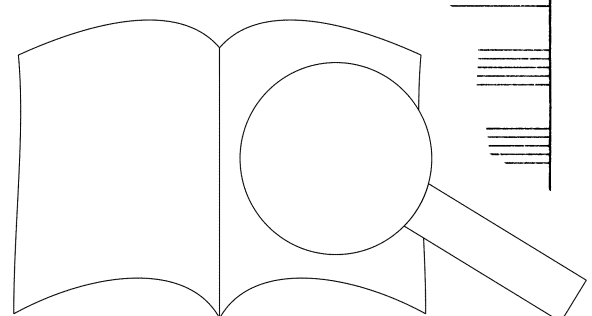

Ob1 *mf espr*

Fg 1

Tr 1

Solo *te - er - - go, te er-go, te - quae - su - - mus.*

1 *div. mf f espr 3 Soli mf*

2 *div. mf f espr 3 Soli mf*

Vla *mf f espr 3*

Vc *f pizz*

111

Ob1 *mf*

Fg1 *mf*

Tr1 *mf espr*

Solo *tu - - - is fa - mu -*

S *p*

A *p*

T *p*

B *p*

Te er-go quae-su-mus,

Te er-go quae-su-mus,

Vla *div. mf f espr 3*

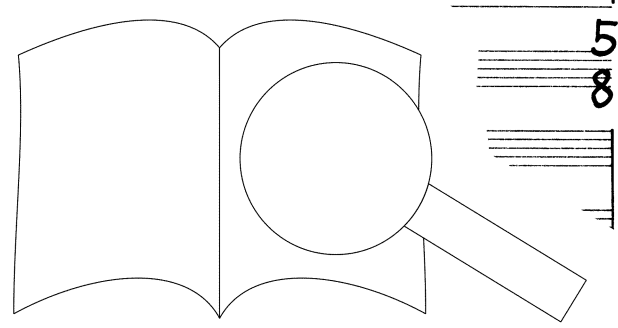

PROBENPARTITUR
 Ausgabequalität gegenüber Original evtl. gemindert • Evaluation Copy - Quality may be reduced • Carus-Verlag

Empty musical staves for various instruments.

117
 1
 Pos 2
 3
 Solo
 lis sub-ve-ni, sub-ve- - - sub- - -ve- - -ni,
 Musical notation for Solo part with lyrics and dynamic markings (mf).

S
 A
 T
 B
 te er-go quae-su-mus, quae-su-mus, | tu-is fa-mu-lis
 te er-go quae-su-mus, | tu-is fa-mu-lis
 Musical notation for vocal parts (Soprano, Alto, Tenor, Bass) with lyrics.

1
 VI
 2
 Vla
 Musical notation for Violin I, Violin II, and Viola parts.

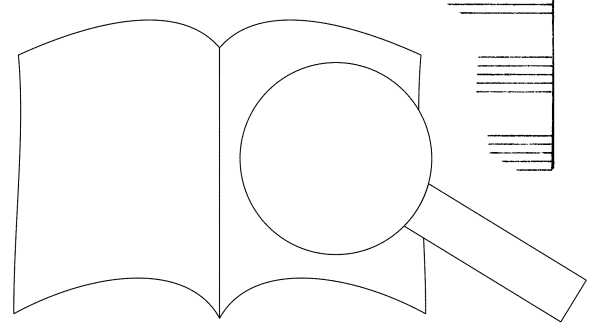

PROBENPARTITUR
 Ausgabequalität gegenüber Original evtl. gemindert • Evaluation Copy - Quality may be reduced • Carus-Verlag

HYMNUS: Guillaume Dufay

131

p

Soprano (S), Alto (A), Tenor (T), Bass (B) vocal parts with lyrics: Cu - ius cor - pus sanc - ti

2 3
4 4

Guitar (G) and Solo part with lyrics: re - de - mi - sti, - quos pre - ti - o - - so san - gui - ne

2
4

Soprano (S), Alto (A), Tenor (T), Bass (B) vocal parts with lyrics: de - mi - sti, quos pre - ti - o - so san - gui - ne,

2 3
4 4

Violin I (VI 1), Violin II (VI 2), Viola (Vla), Violoncello (Vc), Kontrabaß (Kb) instrumental parts

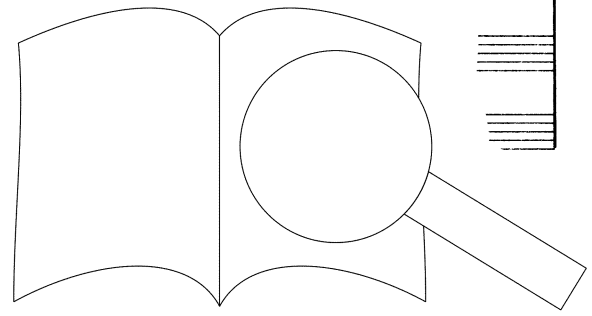

PROBEEPARTITUR
Ausgabequalität gegenüber Original evtl. gemindert • Evaluation Copy - Quality may be reduced • Carus-Verlag

139

F II S
mum in a - - ra cru - cis tor - ri - dum,

A
mum in a - - ra cru - - cis tor - ri - dum,

T
mum in a - - ra cru - - cis tor - ri - dum,

B
mum in a - - ra cru - - cis tor - ri - dum,

Gsp

Solo
tu - is fa - ve o - so san - gui - ne

S
so San - gui - ne, san - gui - ne

A
so San - gui - ne, san - gui - ne

T
ti - o - so San - gui - ne, san - gui - ne

B
ti - o - so San - gui - ne, san - gui - ne

4
4

1
VI

2
VIa

Vc

V

pp
pp
pp
pp
pp
p

Empty musical staves for the upper part of the score.

147
 F II S A T B
 cru - o - - re e - ius ro - - se - - o gu - stan - do vi - vi - mus
 cru - o - - re e - ius ro - - se - - o gu - stan - do vi
 4 3 4
 4 4
 Glsp 4 3 4
 4 4
 Solo

S A T B
 re - de - mi - sti, re - de - mi - sti.
 re - de - mi - sti, re - de - mi - sti.
 4 3 4

1 2
 VI
 Vla
 Vc
 Kb

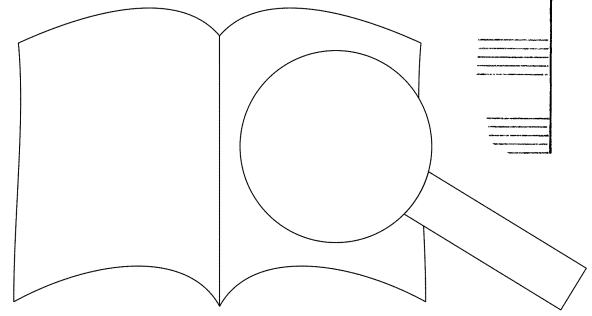

PROBEPARTITUR
 Ausgabequalität gegenüber Original evtl. gemindert • Evaluation Copy - Quality may be reduced • Carus-Verlag

Empty musical staves for the top section of the score.

161
Tr
2
1
Pos 2
3
Solo
tu - is

S
A
T
B
mf
f
glo - ri - a
glo - ri - a
ra - ri.
ne - ra - ri.
nu - ne - ra - ri.
mu - ne - ra - ri.
a - mu - ne - ra - ri.
a - mu - ne - ra - ri.

Vla
Vc
Kb
p

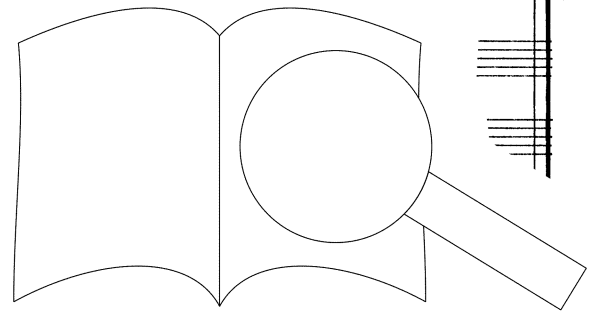

PROBENPARTITUR
Ausgabequalität gegenüber Original evtl. gemindert • Evaluation Copy - Quality may be reduced • Carus-Verlag

III

Ruhig bewegt

$\text{♩} = \text{ca } 184 - 192$

Fl
Ob
Fg
Tr
Pos
Solo
S
A
T
B
Vi 1
Vi 2
Kb

7/8 3/4 7/8

7/8

con sord
mf
ff
pp
sub.pp
b.p.

PROBEPARTITUR

Ausgabequalität gegenüber Original evtl. gemindert • Evaluation Copy - Quality may be reduced • Carus-Verlag

8

Ob 1 *mf*

Fg 1 *mf*

Fg 2 *mf*

Tr 1 *mf*

Pos 1 *mf*

Solo *mf*

S

A

T

B

V1 *Solo p*

V2

Via

Ve

Kb

mf

p

Tutti

Sal - - - - - vum - - - - - fac po - - - - - um tu - um, - - - - -

Do - mi - ne,

Do - mi - ne,

3
4

7
8

14

Fl 1

Fg 2

Tr 1

Tr 2

Pos 1

Solo

S

A

T

B

Vi 1

Vi 2

V

Kb

Do - mi - ne, Do - mi - ne, sal - -

Do - mi - ne, Do - mi - ne

ne - - dic hae - re - di -

3 7

4 8

3 7

4 8



PROBENPARTITUR

Ausgabequalität gegenüber Original evtl. gemindert • Evaluation Copy - Quality may be reduced • Carus-Verlag

Empty musical staves for various instruments.

Musical score for various instruments and voices. Includes parts for Flute (Fl), Oboe (Ob), Bassoon (Fg), Trumpet (Tr), Solo, Soprano (S), Alto (A), Tenor (T), Bass (B), Violin (Vi), Viola (Vla), Violoncello (Vc), and Kontrabaß (Kb). The score includes lyrics: "ta - - - ti tu - - - ae, - - - os et ex -".

Dynamic markings: *mf*, *p espr*, *mp*, *pp*.

Tempo/Performance markings: *p espr*.

Rehearsal marks: 7, 8, 4, 7, 8.

PROBENPARTITUR
 Ausgabequalität gegenüber Original evtl. gemindert • Evaluation Copy - Quality may be reduced • Carus-Verlag

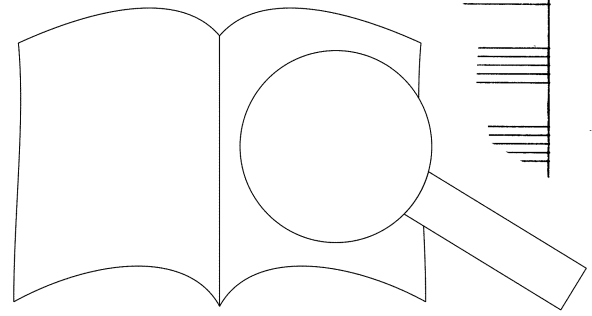

ritard. → animato

$\text{♩} = \text{ca } 76 - 80$

pp sempre poco a poco cresc. ♩

43

F I

S
A
T
B

F II

S
A
T
B

Fl

Tr. 2

Solo

S
A
T
B

1
2

V I
V
Kb

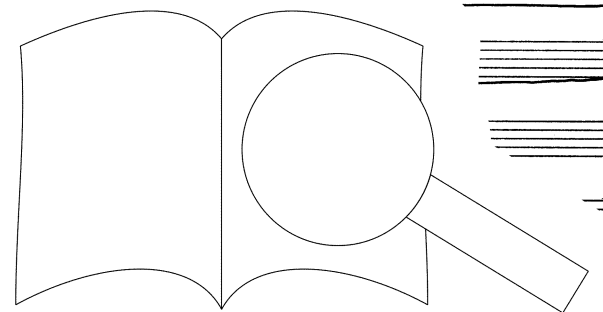

PROBENPARTITUR

Ausgabequalität gegenüber Original evtl. gemindert • Evaluation Copy - Quality may be reduced • Carus-Verlag

Empty musical staves for the upper part of the score.

49
 F I
 S
 A
 T
 B
 per sin-gu-los di-es be-ne-di-ci-mus te, be-ne-di-ci-mus te, be-ne-di-ci-mus te, per sin-gu-los di-es be-ne-, be-ne-

F II
 S
 A
 T
 B
 di-ci-mus te, per sin-gu-los di-es be-ne-di-ci-mus te, be-ne-di-ci-mus te, -ci-mus te,

Solo

f poco a poco cresc
 S
 A
 T
 B
 Per sin - gu - los di -
 Per sin - gu - los di -

1
 Vi
 2
 Via
 Vc
 Kb

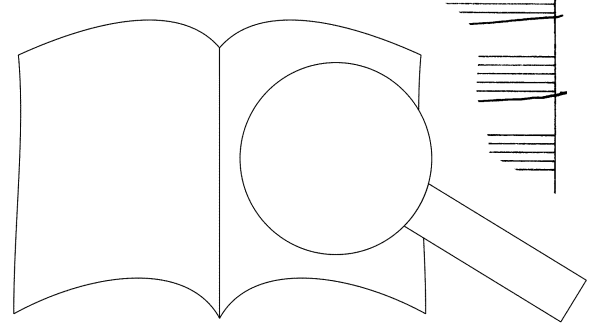

PROBENPARTITUR
 Ausgabequalität gegenüber Original evtl. gemindert • Evaluation Copy - Quality may be reduced • Carus-Verlag

First system of vocal staves (Soprano, Alto, Tenor, Bass) with lyrics: *di-ci-mus te, be-ne-di-ci-mus te, per sin-gu-los di-es be-ne-di-ci-mus te,*

Second system of vocal staves with lyrics: *per sin-gu-los di-es be-ne-di-ci-mus te, per*

Instrumental staves for Tr 1, Tr 2, Pos 1, Pos 2, Pos 3, and Pk. Includes markings: *Senza sord*, *ff*, *pp*, *3*

Solo vocal staves (Soprano, Alto, Tenor, Bass) with lyrics: *es be-ne-di-ci-mus*

Instrumental staves for Violins (V1, V2) and Keyboard (Kb). Includes markings: *pp*

PROBENPARTITUR
 Ausgabequalität gegenüber Original evtl. gemindert • Evaluation Copy - Quality may be reduced • Carus-Verlag

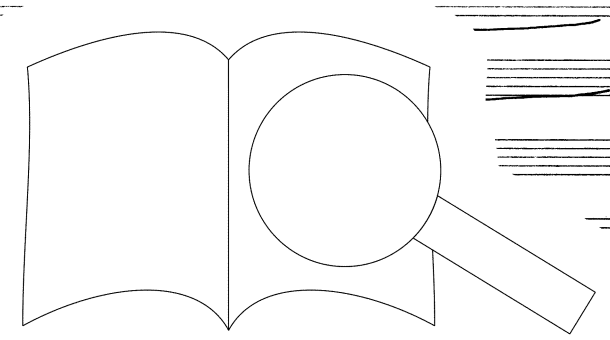

57 *p sempre poco a poco cresc*

S
A
T
B

be-ne-di-ci-mus te, te, per sin-gu-los di-es be-ne-di-ci-mus te, be-ne-di-ci-mus te,

p sempre poco a poco cresc

S
A
T
B

di-ci-mus te, be-ne-di-ci-mus, per sin-gu-los di-es be-ne-di-ci-mus te, per sin-gu-los di-ci-mus te, be-ne-di-ci-mus

Solo

mf cresc

S
A
T
B

per sin-gu-los di-es be-ne-di-ci-mus

1
Vi
2
Vla
Vc
Kb

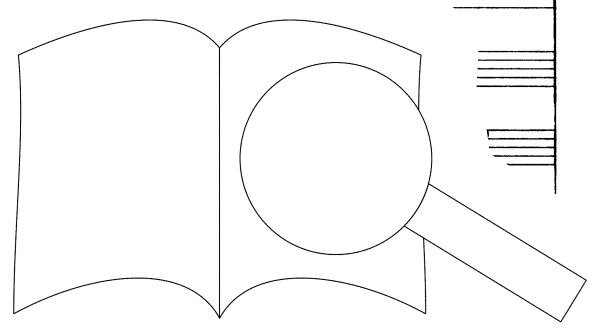

PROBENPARTITUR
Ausgabequalität gegenüber Original evtl. gemindert • Evaluation Copy - Quality may be reduced • Carus-Verlag

61

FF

F I S A T B

et lau - - - da - - - mus,

Fl

Ob1

Tr1

Pos

Glsp

Solo

S A T B

te, et lau - - - da - - - n

te, et lau - - - dr

te, et lau - - -

no - - - men, no-men

n, no-men tu-um in sae-cu-lum, no-men, no-men tu-um in sae-cu-lum

no - - -

1

2

Vl

Vc

Kb

sul ponticello

pp

66

ff

F I S

A

T

B

Fi

Ob¹₂

Fg¹₂

Tr¹₂

Pos¹_{2/3}

Pk

Glsp

Solo

S

A

T

B

tu-um in sae-cu-lum, no-men tu-um in sae-cu-lum, no-
 no-men in sae-cu-lum, no-men tu-um :
 no - - men, no - -
 - - - - - men,

in
 in
 in
 in

no-men tu-um in sae-cu-lum et in sae-
 ae-cu-lum, no-men tu-um in sae-cu-lum et in sae-
 in sae - cu - lum et in sae-
 in sae-cu-lum, no-men tu-um in sae-cu-lum et in sae-

1

2

Vla

Vc

Kb

Soprano (S), Alto (A), Tenor (T), Bass (B) vocal staves with lyrics: "da - - - mus."

Flute (Fl), Oboe 1 & 2 (Ob 1, 2), Clarinet in Bb (Fg 1, 2), Trumpet 1 & 2 (Tr 1, 2), Trombone 1, 2 & 3 (Pos 1, 2, 3), Saxophone (Sax), Solo staves.

Vocal staves with lyrics: "da - - - mus no - men, no - men tu - um in sae - cu - lum sae - cu - li, no - men et in sae - cu - lum sae - cu - li, no - men no - - - men, no - - -"

Violin 1 & 2 (Vi 1, 2), Viola (Via), Violoncello (Vc), Kontrabaß (Kb) instrumental staves.

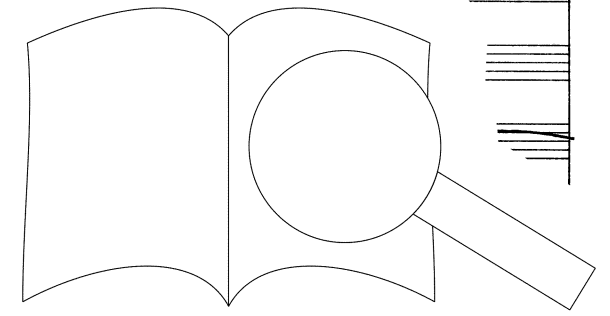

PROBEEPARTITUR
 Ausgabequalität gegenüber Original evtl. gemindert • Evaluation Copy - Quality may be reduced • Carus-Verlag

meno mosso

♩ = ca 60

80

1 2 1 2 1 3

FG Tr Pos 2 3 Pk

Solo

mf

Di - na - - - - re,

S A T B

tu - um in sae - cu - lum sae - cu - li, no - men tu - um in. cu - lum sae - cu - li.

men no tu sae - cu - lum

men no

1 2

Vi Kb

PROBEEPARTITUR
Ausgabequalität gegenüber Original evtl. gemindert • Evaluation Copy - Quality may be reduced • Carus-Verlag

84 **animato** $\text{♩} = \text{ca } 76$ **meno mosso** $\text{♩} = \text{ca } 60$ **tranquillo** $\text{♩} = \text{ca } 54$ *p*

S
A
T
B

Mi
Mi
Mi
ke
Mi

Ob 1
Ob 2

Fg 1
Fg 2

Tr 1
Tr 2

Pos 1
Pos 2
Pos 3

Pk

Solo

f dig - na - - re *p* di - e - - ca - to nos cu - sto - di - - - re

S
A
T
B

p Do - mi - ne, Do - mi - ne, Do - mi - ne.
Do - - mi - - ne.
Mi - se - re - re, mi - se - re -

VI 1
VI 2

Vla

Vc

Kb

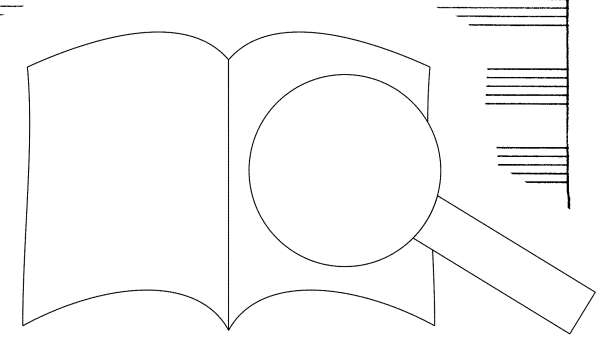

PROBEPARTITUR
Ausgabequalität gegenüber Original evtl. gemindert • Evaluation Copy - Quality may be reduced • Carus-Verlag

FI S
A
T
B

se... re... re...

Fl
Ob 1
Ob 2
Fg 1
Fg 2

f cresc
mf cresc

Tr 1
Pos 1
Pos 2
Pos 3
Pk
Glsp

mp cresc
mp cresc

S
A
T
B

Mi-se-re-re, mi-se-re-re, mi-se-re-re, mi-se-re-re no-stri, Do-mi-

Vi 1
Vi 2
V
Kb

mf cresc
p cresc

pizz f
pizz f

PROBENPARTITUR

Ausgabequalität gegenüber Original evtl. gemindert • Evaluation Copy - Quality may be reduced • Carus-Verlag

97

p

FX

S
A
1
T
2
1
B
2

mi - se - re - re no - - - - - bis.
mi - se - re - re no - - - - - bis,
mi - se - re - re, mi - se - re - re no - - - - - bis.
mi - se - - - re - - - re no - - - - - bis.
mi - se - - - re - - - re no - - - - - bis,
mi - - - se - re - - - - re no - - - - - bis.

ausserst
♩ = ca 38

Fl
1
Ob
2
Fg 1
2

Tr 1
1
Pos
3
Pk

S
A
T
B

mi - se - re - re no - stri, mi - se - re - re no - stri!

poco marcato

Fi - at

1
2
Vi
Vi
Kb

PROBEPARTITUR

Ausgabequalität gegenüber Original evtl. gemindert • Evaluation Copy - Quality may be reduced • Carus-Verlag

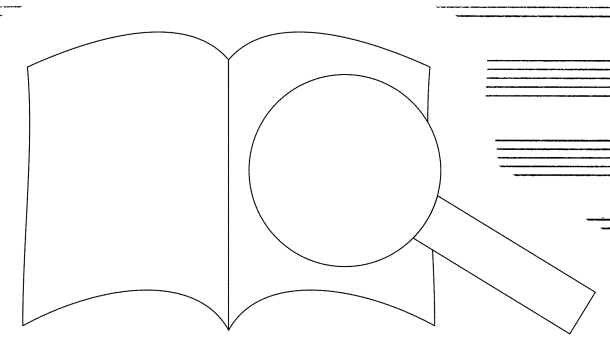

102 *ruhig*

F II

S

A

1 T

2 T

1 B

2 B

1 Fg

2 Fg

1 Tr

2 Tr

1 Pos 2

3 Pos 2

Pk

poco marcato

poco marca!

p

p

p

tr

S

A

T

B

legatissimo

In te, Do-mi-ne, spe-ra-vi,

legatissimo

In te, Do-mi-ne, spe-ra-vi,

mi-se-ri-cor-di-a tu.

um spe-ra-mus in te.

In te, Do-mi-ne spe-ra-

1 VI

2 VI

Vla

Vc

Kb

PROBE PARTITUR

Ausgabequalität gegenüber Original evtl. gemindert • Evaluation Copy - Quality may be reduced • Carus-Verlag

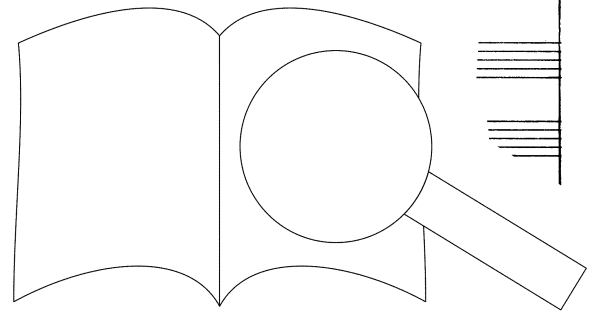

107 *p* *f*

FI S non con-fun-dar in ae-ter-num. A - - - - - men.

A non con-fun-dar in ae-ter-num. A - - - - - men.

T non con-fun-dar in ae-ter-num. A - - - - - men.

B non con-fun-dar in ae-ter-num. A - - - - - men.

Fl

Ob 2

1

2

Fg

1

2

Tr

1

2

Pos 2

3

Pk

S non con-fun-dar in ae-ter-num. A - - - - - men.

A non con-fun-dar in ae-ter-num. A - - - - - men.

T non con-fun-dar in ae-ter-num. A - - - - - men.

B non con-fun-dar in ae-ter-num. A - - - - - men.

1

2

Vi

Vi

Kb

mf espr

mf espr

mf espr

mf espr

PROBEEPARTITUR

Ausgabequalität gegenüber Original evtl. gemindert • Evaluation Copy - Quality may be reduced • Carus-Verlag

PROBE-PARTITUR
Ausgabequalität gegenüber Original evtl. gemindert • Evaluation Copy - Quality may be reduced • Carus-Verlag 

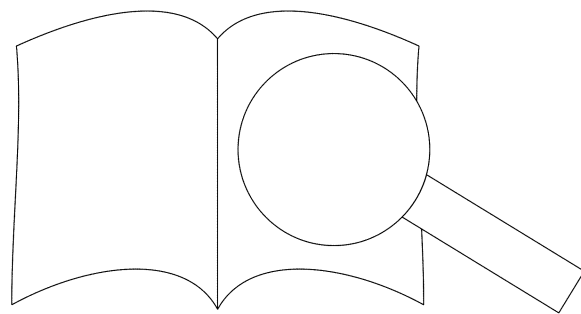

Bach, Johann Sebastian

- Messe in h-Moll BWV 232 (Edition Deluxe – 2 CDs + DVD) 83.315
Gächinger Kantorei Stuttgart, FBO, H.-C. Rademann
- Weihnachtsoratorium BWV 248 (2 CDs) 83.312
Gächinger Cantorey, H.-C. Rademann
- Erhalt uns, Herr, bei deinem Wort 83.311
Gächinger Cantorey, H.-C. Rademann
- Matthäus-Passion (Edition Deluxe – 3 CDs) 83.286
Kammerchor Stuttgart, Barockorchester Stuttgart, F. Bernius
- Osteroratorium BWV 249 & Himmelfahrtsoratorium BWV 11 83.290
Kammerchor Stuttgart, Barockorchester Stuttgart, F. Bernius
- Ein feste Burg. Cantata BWV 80 & Missa in g BWV 235 83.282
Kammerchor Stuttgart, Barockorchester Stuttgart, F. Bernius
- Motetten 83.298
Kammerchor Stuttgart, F. Bernius
- BACHArkaden 83.381
Calmus Ensemble, Lautten Compagny, W. Katschner
- Solokantaten mit Emma Kirkby 83.302
Emma Kirkby, Freiburger Barockorchester
- Vom Himmel hoch. Weihnachtliche Musik von Bach 83.233
Kammerchor der Frauenkirche Dresden, M. Grünert
- Kantaten für Solo-Sopran 83.309
Dorothee Miels, L'Orfeo Barockorchester, Michi Gaigg

Beethoven, Ludwig van

- Missa solemnis (2 CDs) 83.501
Kammerchor Stuttgart, Hofkapelle Stuttgart, F. Bernius
- Missa in C / Cherubini: Sciant gentes 83.295
Kammerchor Stuttgart, Hofkapelle Stuttgart, F. Bernius

Brahms, Johannes

- Geistliche Chormusik (Carus Classics) 83.332
The Schütz Choir of London, R. Norrington
- II: Weltliche Chormusik I: op. 42; op. 62; op. 92; 83.107
Kölner Kammerchor, P. Neumann
- III: Liebeslieder-Walzer (Weltliche Chormusik II) 83.118
Kölner Kammerchor, P. Neumann
- IV: Geistliche Chormusik. Warum ist das Licht · Motetten 83.201
Kammerchor Stuttgart, F. Bernius
- V: Ein deutsches Requiem op. 45 83.200
Klass. Philharmonie, Kammerchor Stuttgart, F. Bernius

Eccard, Johannes

- Fröhlich will ich singen. Sacred and Secular Songs 83.449
Staats- und Domchor Berlin, Lautten Compagny, K.-U. Jirka
- Preussische Festlieder. Sacred Songs 83.265
Vocal Concert Dresden, Capella de la Torre, P. Kopp

Händel, Georg Friedrich

- Acis und Galatea (Bearbeitung von Mendelssohn) 83.420
NDR Chor, FestspielOrchester Göttingen, N. McGegan
- Israel in Egypt HWV 54 (2 CDs) 83.423
Vocalensemble Rastatt, Les Favorites, H. Speck
- Jephtha HWV 70 (3 CDs) / Kammerchor der Frauenkirche, 83.422
Dresdner Barockorchester, M. Grünert
- L'Allegro, il Penseroso ed il Moderato HWV 55 83.29
Kölner Kammerchor, Collegium Cartusianum, P. Neumann
- Messiah HWV 56 (2 CDs) 83.2
Kammerchor Stuttgart, Barockorchester Stuttgart, F. Bernius
- Brookes-Passion HWV 48 (2 CDs) 83.2
Kölner Kammerchor, Collegium Cartusianum, P. Neumar
- Saul HWV 53 (3 CDs) / Dresdner Kammerchor, 83.2
Dresdner Barockorchester, H.-Chr. Rademann
- Solomon HWV 67 (3 CDs) / Winchester Cathedral Choir, 83.2
FestspielOrchester Göttingen, N. McGegan
- Die großen Händel-Oratorien (13 CDs in Box) 83.2
Kölner Kammerchor, Kammerchor Stuttgart, Vocalensemble Rastatt, Winchester Ca'

Haydn, Joseph

- Stabat Mater 83.452
Kammerchor Stuttgart, Hofkapelle Stuttgart

Herzogenberg, Heinrich von

- Frühling lässt sein blaues 83.452
ensemble cantissimo, N. McGegan
- Jauchzet dem Herrn, alle 83.408
ensemble cantissimo, N. McGegan
- Wie schön, hier 83.451
Solistenquartett, Utz

Homilius, Gottff

- Musik an der 83.183
Dresdner Hofkapelle, R. Kreile
- M 83.260
ritz Näf
- 83.261
ockorchester, R. Kreile
- geht" (2 CDs) 83.262
Jsseldorfer Hofmusik, F. Näf
- Motetten I 83.210
F. Bernius
- Motetten II 83.266
em Herrn. Motetten II
- 83.267
Heiden. Kantaten
- 83.235
any Choir, Handel's Company, R. J. Homburg
- 83.235
oratorium · Jacobi: Der Himmel steht
- 83.235
Sä. ies Vocalensemble, Virtuosi Saxoniae, L. Güttler

Mendelssohn Bartholdy, Felix

- Ein Sommernachtstraum. Schauspielmusik op. 21/61 83.205
Kammerchor Stuttgart, Barockorchester Stuttgart, F. Bernius
- Lieder im Freien zu singen 83.287
Kammerchor Stuttgart, F. Bernius
- Jauchzet dem Herrn, alle Welt. Geistliche Chormusik (2 CDs) 83.491
Kammerchor Stuttgart, F. Bernius
- Kirchenwerke (Gesamteinspielung) 83.205
Solisten, Kammerchor Stuttgart, F. Bernius
- Deutsche Kammerphilharmonie Bremen, Klassische Philharmonie 83.205
Stuttgart, Stuttgarter Kammerorchester u.a.
- Geistliches Chorwerk (10 CDs in Box) 83.020
- Oratorien (4 CDs in Box) 83.021
- Alle CDs der Gesamteinspielung sind auch als Einzel-CDs erhältlich.

Mozart, Wolfgang Amadeus

- Missa in c KV 427 83.284
Kammerchor Stuttgart, Hofkapelle Stuttgart, F. Bernius
- Requiem (Beyer) 83.207
Kammerchor Stuttgart, Frieder Bernius
- Vesperae & Litaniae (Carus Classics) 83.316
Estonian Philharmonic Chamber Choir, Tõnu Kaljuste
- Litaniae (Carus Classics) 83.331
Estonian Philharmonic Chamber Choir, Tõnu Kaljuste

Nicolai, Otto

- Herr, auf dich traue ich. Psalmen 83.299
Kammerchor Stuttgart, F. Bernius
- Messe in D 341
Kammerchor Consono, H. Jers

Reger, Max

- Drei Motetten op. 110 83.201
SWR Vokalensemble Stuttgart, Frieder Berr.
- Acht geistliche Gesänge op. 138 83.107
NDR Chor Hamburg, H.-C. Rademann
- Es waren zwei Königskinder 83.118
Dresdner Kammerchor, H.-C. R

Rheinberger, Josef Gabriel

- Musica sacra (10 CDs in Box) 83.336
Kammerchor Stuttgart, Vancouver Cantata Society, Saarbrücken, Chor
- Alle CDs der Sammlung 83.376
Die Wasserferie, L. Teuscher
- Du sonner 83.409
Die Sing.
- Den 83.157
V. Ras. al music
- 83.293
Stuttgart, F. Bernius
- 83.436
Jhannsen
- 83.249
perae solennes de Confessore
- 83.317
skapelle Dresden, Sir Charles Mackerras
- 83.317
Classics
- 83.317
or, Orpheus Orchester Wien, J. Prinz

- 83.232
pielung · Complete recording
- 83.232
Kammerchor, H.-Chr. Rademann
- 83.232
1: Geistliche Chor-Music 1648 (2 CDs)
- 83.237
ol. 2: Italienische Madrigale
- 83.238
Vol. 3: Musikalische Exequien (CD)
- 83.239
- Vol. 4: Zwölf geistliche Gesänge
- 83.252
- Vol. 5: Cantiones Sacrae (2 CDs)
- 83.253
- Vol. 6: Lukaspassion & Die Sieben Worte
- 83.254
- Vol. 7: Kleine geistliche Konzerte I
- 83.255
- Vol. 8: Psalmen Davids (2 CDs)
- 83.256
- Vol. 9: Auferstehungshistorie
- 83.257
- Vol. 10: Weihnachtshistorie
- 83.259
- Vol. 11: Matthäuspassion
- 83.258
- Vol. 12: Symphoniae Sacrae III (2 CDs)
- 83.270
- Vol. 13: Johannespassion
- 83.273
- Vol. 14: Symphoniae Sacrae I (2 CDs)
- 83.276
- Vol. 15: Becker-Psalter
- 83.276
- Vol. 16: Schwanengesang, Der 119. Psalm
- 83.271
- Vol. 17: Kleinere Psalmen
- 83.274
- Vol. 18: Kleine geistliche Konzerte II
- 83.277
- Vol. 19: Kleine geistliche Konzerte III
- 83.278
- Vol. 20: Kleine geistliche Konzerte IV

Schumann

- Der Ros 83.450
Süddeutsche Kammerchor
- An die 83.327
Orpheus

Zelenka, J

- Missa S 83.450
Kammerchor Stuttgart, Hofkapelle Stuttgart
- Missa I 83.327
Kammerchor Stuttgart, Hofkapelle Stuttgart
- Missa v 83.450
Kammerchor Stuttgart, Hofkapelle Stuttgart

